

RISO MZ Series

User's Guide

990/790/770

RISO MZ Series *User's Guide* 990/790/770



Please contact following for supplies and service:



Riso shall not be responsible for any damage or expense that might result from the use of this manual.

As we are constantly improving our products, the machine may differ in some respects from the illustrations used in this manual.

Riso shall not be liable for any direct, incidental, or consequential damages of any nature, or losses or expenses resulting from the use of this product or included manuals.

 Caution:

- Make sure to read the important operational safety information.
- Store this manual close-by, and fully acquaint yourself with the printing machine.

RISO is a registered trademark of RISO KAGAKU CORPORATION in Japan and other countries.

riso iQualitySystem™ is a trademark of RISO KAGAKU CORPORATION.



 is a trademark of RISO KAGAKU CORPORATION.

- This product contains RFID (Radio Frequency Identification) System.
- The information contained in this document is subject to change without notice.

Copyright © 2008 RISO KAGAKU CORPORATION

Contents

Welcome to the MZ Series Model	7
About This User's Guide.....	7
Icons Used in This Manual	8

Before Starting to Use **10**

Safety Guide - Installation	10
Installation	10
Power connection	10
Safety Guide - Handling and Operation.....	11
Operation Environment.....	11
Machine Handling.....	11
Consumables.....	12
Ink Handling.....	12
Connection with a Computer	13
Paper Recommendations	14
Size and Weight Restrictions.....	14
Tips for Better Paper Feeding	15
Storing Environment	15
Originals	16
Size and Weight Restrictions.....	16
Maximum Printing Areas and Margins.....	17
Materials Not to Be Printed	17

Getting Acquainted **18**

Function and Name of Each Part	18
Optional Devices	20
Control Panel.....	22
Display.....	24
The Screens and their Various Stages.....	24
Basic Screen Layout.....	27

Basic Operations **32**

Preparing to Print.....	32
Turning the power ON	32
Setting up the Paper Feed Tray and Loading Paper	33
Setting up the Paper Receiving Tray.....	35
Basic Process.....	37
2-Color Printing with 2 Originals.....	40
2-Color Printing with 1 Original [Easy 2Color]	46
Easy 2Color Types	46
Operating Procedures for Easy 2Color.....	51
Printing with 1-Color	58

Printing from a Computer Data [Direct Print]	63
Printing Computer Data	64
Changing Output Directions	67
Changing Stop Timing	68
Functions for Master-Making	70
Selecting Image Processing Mode [Image]	70
Processing Photos with Dot Screen [Dot Process]	72
Adjusting Photo Contrast [Contrast Adj]	74
Adjusting Photo Gradation [Tone Curve].....	75
Selecting Scanning Contrast for the Original [Contrast]	77
Enlarging/Reducing Originals [Standard Ratio] [Free] [Margin+] [Zoom]	78
Enlargement and Reduction by Standard Ratio [Standard Ratio] [Margin+]	79
Magnification/Reduction of a Changed Aspect Ration [Free]	80
Enlarging and Reducing with the Zoom Function [Zoom]	81
Using Custom-Sized Paper [Paper]	82
Automatic Printing [Auto-Process]	83
Printing from Bound Documents [Book Shadow]	84
Saving Ink [Ink Saving]	86
Printing Side-by-Side on One Sheet [2 Up] [Multi-Up Print]	87
Original Orientation and Print Results	88
Orientation of Print Paper	90
Enlargement/Reduction Ratio.....	91
2 Up Operation	93
Operation for Multi-Up Printing	94
Operation for Multi-Up Tickets.....	96
Switching Masters of Just One Cylinder (Drum) [OneSide MasterMake].....	98
Making a Master that Utilizes the Maximum Printing Area [Max. Scan]	101
Reproducing the Master [Renew Page].....	102
Recreating a Master	103
Using Auto Page Renewal.....	104
Cutting the Top Margin of the Original and Printing [Top Margin]	105
Adjusting the Side Margins of the Master [Side Margin].....	107
Checking the Print Image Prior to Making Master [Preview]	109
Actions Available on the Preview Screen	110
Setting and Printing the Preview Display.....	110

Functions for Printing 112

Changing the Print Speed [Print Speed Adjustment]	112
Printing at High Speed [150ppm].....	113
Setting “150ppm”	113
Adjusting the Print Density [Print Density Adjustment]	114
Adjusting the Print Position [Print Position Adjustment] [1=2 Alignment]	115
Adjusting the Print Position of Both Cylinders (Drums) Together	116
Printing Proof Copies [Proof]	118
Prevent Paper Jams When Using Special Paper [D-Feed Check].....	119
Keeping Printed Copies Dry [Interval]	120
Paper Feed/Output Settings for Special Paper and Printing Types	
[Jump Wing Control] [Special Paper Ctrl].....	122
Setting the Jump Wing Control [Jump Wing Control]	123
Retrieving Settings from the Parameter List.....	124
Saving settings in the Parameter List	126
Making changes to Special Paper Ctrl Setting	129
Clearing Special Paper Ctrl Settings	130

Advanced Features 132

Automatic Sorting Into Groups [Program]	132
How to Program Print	135
Setting Up for Programed Printing.....	136
Saving Programs	139
Renaming a Program	141
Clearing Programs	143
Retrieving a Program	144
Making changes to Stored Programs	145
Programming Example	146
Using Job Memory Functions [Job Memory]	150
Storing Job Memory	151
Renaming a Job Memory	153
Retrieving a Job Memory and Printing	155
Clearing Job Memory	157
Extending the Reserve Period [Reservation]	159
Idling Action [Idling Action]	160
Protecting Confidential Documents [Confidential]	162
Selecting Scanning Sides When Using the Auto Document Feeder DX-1 [Scanning Side -ADF]	164
Specifying the Scanning Side.....	167
Showing Usage Status [Counter Display].....	169
Rotating the Original 180 Degrees to Make a Master [Rotate].....	170
Proof and Print (with the Optional ADF unit installed) [ADF Semi-Auto]	171
Changing Default Settings [Admin.]	173
Configurable Functions.....	173
Customizing the Default Settings	179
Setting Up Direct Access Area and Selections Tab [DirectAccess Entry] [Selections Entry].....	182

Registering a Custom Paper Size [Custom Paper Entry]	186
Entering sizes and changing names.....	186
Deleting a Custom Paper Size	189
Keeping Masters Secure After Printing	190
Preventing Leaks of Masters After Creation or Disposal [Protect]	191

Storage and Scan Modes (Option) 194

About Storage	194
Storable Original Data	194
Retrieving Storage Data	195
Converting Hard-copy to Stored Data (Scan Mode).....	196
About Scan Mode	196
Scanning an Original for 1-Color Printing	197
Scanning Originals (2) for 2-Color Printing.....	199
Setting Data Information	201
Specifying Paper Size	203
Retrieving Stored Data and Printing [Storage Memory]	204
Retrieving Storage Data	204
Using the Storage Retrieve Screen	206
Changing the Data Order	207
Overlaying Storage Data onto a 1-Color Print Job [Overlay].....	208
2-Color Printing with the Original and Storage Data [Stamp]	210
Registering a Stamp Data to insert.....	211
Renaming the Stamp Data	213
2-Color Printing with [Stamp].....	215
Changing the Stamp Data	217
Deleting a Stamp Data	219

When using a Linked Printer (sold separately) 222

Print Functions for Using Linked Printers	222
Setting up a Linked Printer [Link Properties]	224
Linked Printer Setup List	224
Setting up a Linked Printer	227
Printing Scanned Original from a Linked Printer [Link Mode].....	228
Using Optional Functions on a Linked Printer	231
Configurable Functions.....	232
Duplex Printing [Duplex]	235
Using the Stage Glass or Auto Document Feeder AF-VI:II	235
When Equipped with the Auto Document Feeder DX-1	238

Replacing Consumables	242
------------------------------	------------

Check for Remaining Amount of Consumables.....	242
Replacing the Master Roll	243
Replacing the Ink Cartridge	246
Emptying the Master Disposal Box	248
Replacing the Print Cylinder (Drum).....	250
Removing the Print Cylinder (Drum).....	250
Installing the Print Cylinder (Drum).....	252
Disposal of Depleted Consumables	253

Maintenance	256
--------------------	------------

Cleaning	256
Thermal Print Head	257
Stage Glass and Stage Cover Pad.....	257
Scanner Glass and White Sheet of ADF unit (Option)	258
Pressure Roller	259
The Exterior	260

Troubleshooting	262
------------------------	------------

When a Message Displays	262
Error Message Layout	262
Pop-Up Message Layout	273
Consumable Information Screen	279
Troubleshooting.....	282

Appendix	292
-----------------	------------

Optional Accessories.....	292
Specifications	293
Index.....	300

Welcome to the MZ Series Model

Thank you for your purchase of this printing machine.
This machine is a digital duplicator with the following functions.

- This machine is equipped with two color cylinders (drums), allowing anyone to easily print in two colors.
- This machine also is equipped with an LCD display and features an easy-to-use Touch Screen operated by touching buttons displayed on the screen.
- With an interactive guidance system, highly-sophisticated printer settings can be made with ease.

About This User's Guide

This machine comes with the following 4 user's guides.

◆ RISO MZ Series User's Guide (this manual)

This user's guide explains basic printer operations, handy tips, and how to set up the high-speed print function. It also contains user cautions, information on storing and changing consumables, and troubleshooting procedures. It also contains an explanation for using **[Link Mode]** when an optional linked printer is attached.

◆ RISO Editor User's Guide

This user's guide explains the RISO Editor functions.

◆ Reference Guide NAVIGATION BOOK

This book explains in easy-to-understand language the mechanisms and operational flow of 2-Color printing and Easy 2Color, as well as tips for printing.

◆ RISO Printer Driver User's Guide / Installation Guide (included as a PDF file in the attached CD-ROM)

This user's guide explains the procedures for printing from a computer.







This manual shows you the machine's basic and advanced operations using various functions. It also contains cautionary notes, usage and replacement information on consumable supplies and troubleshooting tips. Please read this manual carefully before using this machine. Reference at any time as needed for more tips and ideas.

Icons Used in This Manual

The following icons are used in this manual.

About the Notation

The following icons are used throughout the document.

-  **WARNING:** Ignoring this warning could cause death or serious injury.
-  **Caution:** Ignoring this caution could cause injury or damage to property.
- Important!:** Indicates items that require special attention or that are prohibited actions. Read carefully and follow the directions as instructed.
- Note:** Gives you useful information.
- Tip:** Gives you additional hints for more convenience.
-  Indicates a reference page.
- [] Indicates a button or item name on the LCD display.
-  Indicates which button to touch on the LCD display.
-  Indicates the original document.
-  Indicates printed copies.

The notation for Operational Instructions and Function Descriptions

The following conventions are used to explain functions and operations.

1

2

3

Functions for Master-Making

Functions for Master-Making

Selecting Image Processing Mode [Image]

In order to make a master best suited for the original document, select an appropriate mode depending on what the original contains: only text (Line), photo, or both of them.

Note:

- Default Image Processing mode can be set on the Admin. screen. p.160

1 Touch [Image] on the Master Making Basic Screen.



2 Select the appropriate Image Processing mode for the original.



- **[Line]** Only text contained; e.g., text document, newspaper
- **[Photo]** Only photos contained
- **[Duo]** Both text and photos contained
- **[Pencil]** pencil drawings or tightly printed documents

68 Selecting Image Processing Mode [Image]

Touch [Photo] to select the type of photo.

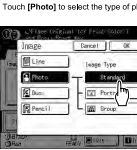

- **[Standard]** Select for photos other than portraits or groups.
- **[Portrait]** Use this setting for pictures of two individuals from the bust up. This image processing is particularly good for photos of faces.
- **[Group]** This setting is for group photos. This process is for restoring facial features that have been washed out by a flash. The Group setting is not for photos that are overly dark. It may be more appropriate to select **[Standard]** for such photos.

69 Selecting Image Processing Mode [Image]

3 Touch [OK].



The following screen appears.

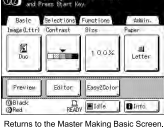

Returns to the Master Making Basic Screen. Image Processing mode is updated.

Note:

- Some functions are not available in certain Image Processing mode settings.

	Line	Photo	Duo	Pencil
DOT Process	✓	✓	✓	—
Contrast (Auto)	✓	—	—	—
Contrast (-S)	✓	✓	✓	✓
Contrast (+S)	—	✓	—	—
Tone Curve	—	✓	✓	✓

✓ : available — : not available

1) Chapter Title

2) Operation Procedure

The operational procedures are outlined in steps. Follow these steps.

3) Display

Shows the screen as seen on each step.

About the content of this manual and the illustrations

- Displays are illustrated as if currently activated. Some buttons presented in this manual may not be available by default setting, or when the optional device is not installed.
- For the illustrations of the machine's outlines and control panels, those for the MZ790U have been used.
- The examples in this user's guide generally assume that Drum 1 is "Black" and Drum 2 is "Red".
- The optional Auto Document Feeder AF-VI:II and Auto Document Feeder DX-1 are collectively described as the "ADF unit".

Important!:

- Measurements in the text body will be shown in both inch (imperial) and metric formats, but diagrams will show only inch (imperial) measurements.

Before Starting to Use

Safety Guide - Installation

This section describes the precautions to be observed when installing the machine. Read this section before installing the machine.

Note:

- Your dealer will help you to determine a proper location for the machine at the time of delivery.

Installation

▲WARNING:

- Place the machine on the dedicated stand for this model or on a flat and stable surface (maximum of $\frac{3}{8}$ inches (10 mm) differential allowed). Injury might occur if the machine falls.
- Install the machine in a well-ventilated area. Failure to do so may result in serious health problems.

▲Caution:

- Install the machine near the electrical outlet to avoid using an extension cord between the machine and the electrical outlet. If an extension cord is absolutely required, do not use one longer than 15 feet (5 m).
- Allow at least 4 inches (10 cm) or more of clearance behind the machine so that you can unplug the machine in case of technical difficulties.
- Keep the machine away from dusty environments. Failure to do so may result in fire.

Important!:

- Avoid installing the machine in the locations listed below. Failure to observe this precaution may lead to machine failure.
 - Locations with exposure to direct sunlight, such as locations close to windows (Curtain all windows that might expose the machine to direct sunlight)
 - Locations that are subject to sudden changes in temperature
 - Extremely hot and humid locations or cold and dry locations
 - Heated locations
 - Locations exposed to direct cold air, direct hot air, or direct radiant heat

Power connection

▲WARNING:

- Do not overload the electrical outlet or extension cord, nor damage the electric cord by placing heavy objects on it or pulling or bending it. This can result in fire or electric shock.
- Do not pull the electric cord but hold the plug itself when unplugging it. This can damage the cord and result in fire or electric shock.
- Do not plug or unplug the electric cord if your hands are wet. This can result in electric shock.

▲Caution:

- Pull out the electric cord plug from the electrical outlet more than once a year and clean the prongs of the plug and their surroundings. Dust collected on these areas can result in fire.

Important!:

- Check the electric cord and plug for poor connections. Plug the electric cord securely into a nearby electrical outlet.
- Be sure to turn off the POWER switch when connecting or disconnecting a cable.

Safety Guide - Handling and Operation

This section describes the precautions to be observed when handling the machine. Read this section before operating the machine.

Operation Environment

Important!:

- Operate the machine under the following appropriate environment conditions.
Temperature range: 59°F to 86°F (15°C to 30°C)
Humidity range: 40% to 70% (noncondensing)

Machine Handling

WARNING:

- Do not place water containers or metallic objects on the machine. Fire or electric shock may occur if water or metallic objects fall into the machine.
- Do not insert any metallic material or flammable substance into the machine through any opening. This can result in fire or electric shock.
- Do not remove machine covers. Exposing internal parts may result in electric shock.
- Do not disassemble or rebuild the machine by yourself. This can result in fire or electric shock.
- If the machine emits excessive heat, smoke or foul odor, immediately turn off the POWER, unplug the electric cord and contact your service representative. Failure to do so can result in fire or electric shock.
- If something drops inside the machine, immediately turn off the POWER, unplug the electric cord and contact your service representative. Failure to do so can result in fire or electric shock.
- Never stick your hands or fingers in the openings of the machine during operation.
- Keep loose clothing or long hair away from moving parts to avoid becoming entangled.
- Do not place heavy objects on the machine. The objects might fall and cause injury.
- Contact your service representative before moving the machine.

Caution:

- Do not open any covers or move the machine during operation.
- Unplug the electric cord, if you do not use the machine for a long time.
- The machine has precision parts and driving parts inside. Do not handle the machine in other ways than described in this manual.
- Do not apply any shock to the machine.

Important!:

- Do not unplug the electric cord or turn off the power during operation.
- Be sure to open and close all machine covers gently.

Consumables

Important!:

- For ink and Master Roll, it is recommended to use the products specified by RISO.
- Store consumables such as Master Roll and ink properly.
Do not store consumables in the following places:
 - Locations that are subject to direct sunlight or bright locations that are close to windows
(If there is no other choice, curtain the window.)
 - Locations that are subject to rapid changes in temperature
 - Extremely hot and humid locations or extremely cold and dry locations

Ink Handling

Caution:

- If ink gets into your eyes, flush it out immediately with plenty of water. If irritation continues, seek medical attention.
- If ink comes into contact with your skin, wash it off thoroughly using soap.
- Allow plenty of ventilation during printing.
- If you feel unwell during use, seek medical advice.
- Only use the ink for printing purposes.
- Keep the ink out of the reach of children.

Connection with a Computer

You can directly send data from a connected computer to the machine as an original for printing. Because digital data itself is used for making a master, the finish of prints becomes outstanding.

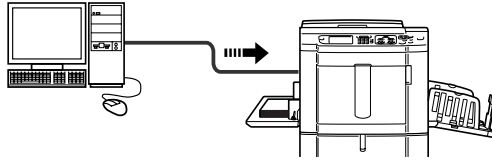

Important!:

- Before making the connections, turn off both the machine and computer.
- The maximum allowable voltage for USB connector input and output is 5 V.

Connection Method	Option Needed	Cable	
One-to-one connection with a Windows PC	—	USB cable ^{*1}	10ft (3m) Hi-Speed USB
One-to-one connection with a Macintosh (Windows PC also acceptable)	RISORINC-NET	Ethernet cable (cross)	Shielded cable that supports 10BASE-T or 100BASE-TX
Network connections	RISORINC-NET	Ethernet cable (straight)	

*1 For installation procedure via USB cable, refer to "Installation Guide" in the CD-ROM.

Paper Recommendations

Size and Weight Restrictions

The table shows the specifications of the usable print paper.

Usable Printing Paper	
Size	Weight
$3^{15}/_{16}$ " \times $5^{13}/_{16}$ " (100 mm \times 148 mm) to $11^{11}/_{16}$ " \times 17" (297 mm \times 432 mm)	13-lb bond (46 g/m ²) to 110-lb index (210 g/m ²)

Note:

- Up to 21.9" (555 mm) of vertical paper dimension may be used (loaded) by setting up "Custom Paper Entry".
☞ p.186
- The minimum size paper that can be used differs for 1-Color and 2-Color printing.
 - **2-Color Print**
 Min. $7^{3}/_{16}$ " \times $10^{1}/_{8}$ " (182 mm \times 257 mm) (B5)
 - **1-Color print with Cylinder (Drum) 1 only**
 Min. $3^{15}/_{16}$ " \times $5^{13}/_{16}$ " (100 mm \times 148 mm)
 - **1-Color print with Cylinder (Drum) 2 only**
 If Cylinder (Drum) 1 is set to "Confidential": Min. $7^{3}/_{16}$ " \times $10^{1}/_{8}$ " (182 mm \times 257 mm) (B5)
 If Cylinder (Drum) 1 is removed: Min. $7^{3}/_{16}$ " \times $10^{1}/_{8}$ " (182 mm \times 257 mm) (B5)
 If Cylinder (Drum) 1 is removed, and the print speed is high (150 ppm): Min. $10^{1}/_{8}$ " \times $14^{5}/_{16}$ " (257 mm \times 364 mm) (B4)

Important!:

- Even when using paper whose specifications are supported size and weight, it may not pass through the machine depending on such factors as paper finish, ambient conditions, and storage conditions. Keep this in mind when using the machine. For more information, consult your dealer.

Do not use the following types of paper, as they can cause jams or misfeeds:

- Extremely thin paper (less than 13-lb bond (46 g/m²))
- Extremely thick or heavy paper (greater than 110-lb index (210 g/m²))
- Wrinkled, curled, folded, or torn paper
- Chemically treated or coated paper (such as thermal or carbon paper)
- Paper having a sticky section or holes (such as an envelope and label paper)

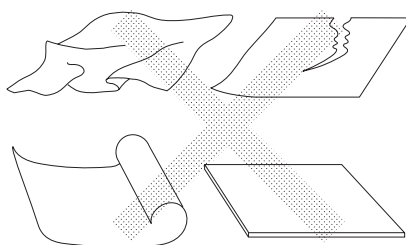

Note:

- Paper with a horizontal grain direction can cause problems with paper pass. Use paper with a vertical grain direction.
- Images are not output onto the entire area of usable print paper.

☞p.17

RISO does not assure that paper outside the above specifications pass through the machine and can be used for printing.

Tips for Better Paper Feeding

To prevent paper jams and misfeeds, follow the directions below:

- When using standard or light-weight paper, set the Paper Feed Pressure Adjustment Lever to “NORMAL”. Then open all four Paper Arrangers. ☞p.33, ☞p.35
- When using thick paper (such as card stock), set the Paper Feed Pressure Adjustment Lever to “CARD”, and open the two inner Paper Arrangers. ☞p.33, ☞p.35
- When using slippery paper, set the Paper Feed Pressure Adjustment Lever to “CARD”. ☞p.33, ☞p.35
- Slide the Feed Tray Paper Guides, Receiving Tray Paper Guides, and Paper Stopper to fit the paper size. ☞p.33
- Use flat printing paper that is free of folds. If curled paper is unavoidable, place the printing paper so that the curl faces down.
- Paper may stick to the cylinder (drum) surface if the top margin is too narrow on the original or if the upper portion of the original uses a large amount of ink. To solve this problem, lower the print position to provide a wider top margin or reverse the top and bottom of the original. Then restart printing from the beginning.

Storing Environment

Store printing paper in a level, dry area. Storing the paper in an excessively humid area can result in paper jams or poor print quality.

After unpacking printing paper, keep the remaining paper wrapped and store it in a moisture-proof box. It is highly recommended to put silica gel in the paper storage box.

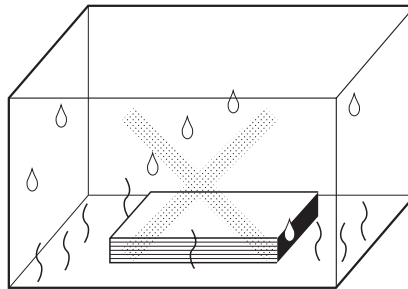

Originals

Size and Weight Restrictions

Usable originals are as follows.

Using the Stage Glass		Using the Optional Document Feeder AF-VI:II		Using the Optional Auto Document Feeder DX-1	
Size	Weight	Size	Weight	Size	Weight
$1\frac{15}{16}'' \times 3\frac{9}{16}''$ (50 mm × 90 mm) to $11\frac{11}{16}'' \times 17''$ (297 mm × 432 mm)	Max. 22 lb (10 kg)	$3\frac{15}{16}'' \times 5\frac{13}{16}''$ (100 mm × 148 mm) to $11\frac{11}{16}'' \times 17''$ (297 mm × 432 mm)	13-lb bond (50 g/m ²) to 34-lb bond (128 g/m ²)	$4\frac{1}{8}'' \times 5\frac{1}{16}''$ (105 mm × 128 mm) to $11\frac{11}{16}'' \times 17''$ (297 mm × 432 mm)	<Front Side -> Simplex>^{*1} 11-lb bond (40 g/m ²) to 34-lb bond (128 g/m ²) <Back Side -> Simplex or Duplex -> Simplex>^{*1} 14-lb bond (52 g/m ²) to 28- lb bond (105 g/m ²)

*1 The paper weight limit differs depending on which sides of the original are scanned. Scanning sides can be specified using "Scanning Side -ADF". p.164

- Originals are scanned according to the size of paper placed on the Paper Feed Tray when masters are made; for the same width, the positions of the Feed Tray Paper Guides.
When the placed paper is smaller than an original, not the entire original will be scanned.
When the placed paper is larger than an original, dirt on the glass or shade of the original, for example, may result in unexpected dirt in the area beyond the size of the original.
- Bound originals can also be used on the Stage Glass.
- You can feed automatically up to 50 original sheets when using the optional ADF (Auto Document Feeder) unit.

Note:

- Use the Stage Glass when printing the following originals:
 - Patched or worn originals
 - Wrinkled, curled, folded, or torn originals
 - Transparent originals (such as tracing paper or OHP transparencies)
 - Chemically treated originals (such as thermal or carbon paper)
 - Originals with correction fluid or glue
 - Extremely thin originals
Using the optional Auto Document Feeder AF-VI:II: less than 50 g/m²
Using the optional Auto Document Feeder DX-1:
less than 40 g/m² (Front Side -> Simplex) / less than 52 g/m² (Duplex -> Simplex)
 - Extremely thick originals
Using the optional Auto Document Feeder AF-VI:II: greater than 128 g/m²
Using the optional Auto Document Feeder DX-1:
greater than 128 g/m² (Front Side -> Simplex) / greater than 105 g/m² (Duplex -> Simplex)
 - Heavy drawing paper
 - Originals with staples or clips
- If an original is wrinkled, curled, or creased flatten it thoroughly so that the originals can be pressed directly onto the Stage Glass during processing.
- If correction fluid or glue is used on an original, thoroughly dry it before placement.
- For an original patched with thick paper, the shade of the patched paper may also be printed.

Maximum Printing Areas and Margins

The maximum printing areas are as follows.

Model	Maximum Printing Area	Usable Maximum Print Paper Size
MZ990/MZ790	$11\frac{7}{16}" \times 16\frac{3}{4}"$ (291 mm \times 425 mm)	$11\frac{11}{16}" \times 17"$ (297 mm \times 432 mm)
MZ770	$11\frac{7}{16}" \times 16\frac{1}{4}"$ (291 mm \times 413 mm)	

Important!:

- No matter which size of originals is printed, the margins indicated on the figure are required for the originals. Reduce the original if necessary to fit it inside of the margins. Place an original so that its end having a $\frac{3}{16}"$ (5 mm) margin at least comes to the left of the Stage Glass.

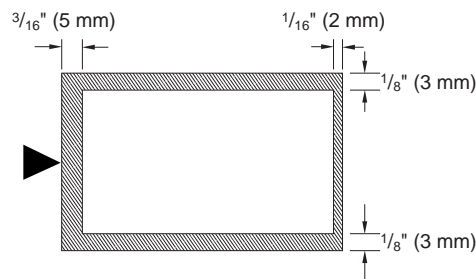

Tip:

About Printing Areas

- Printing area for the master is determined by the actual paper size detected on the Paper Feed Tray, regardless of whether the original is being scanned, or sent from a computer.
 - As shown in the illustration above, the printing area on the master will be smaller than the paper size (allowing $\frac{9}{32}"$ (7 mm) total margins for top and bottom, $\frac{1}{4}"$ (6 mm) for left and right). Peripheral areas in the original document exceeding the printing area for the master will not be printed.
 - The maximum printing area can be applied to the scanned image, regardless of the print paper size.
- ☞ p.101

Materials Not to Be Printed

Do not use the machine in any manner which violates the law or infringes on established copyrights, even when making copies for personal use. Consult your local authorities for further details. In general, use discretion and common sense.

Getting Acquainted

Function and Name of Each Part

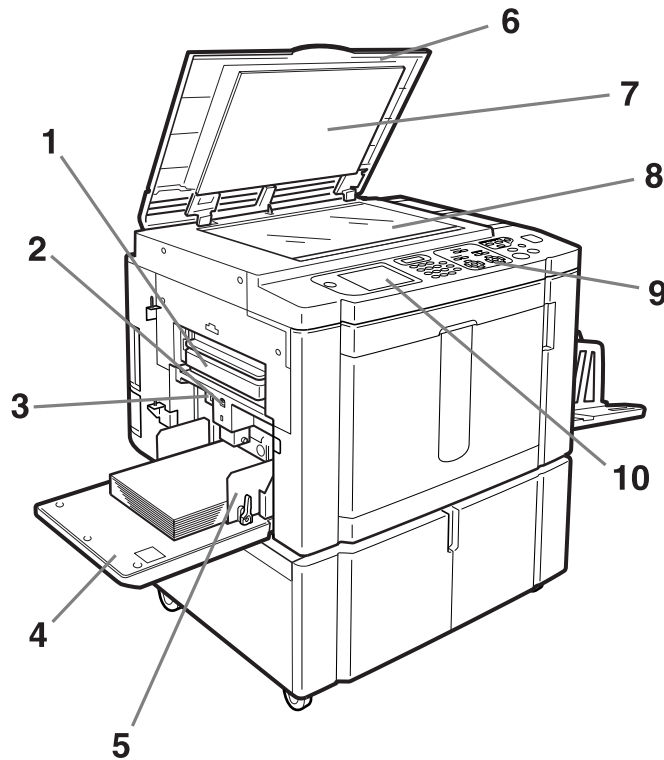

1) Master Disposal Box 1 (☞p.248)

Holds discarded masters.

2) Feed Tray Descent Button (☞p.34)

Lowers the Paper Feed Tray when changing or adding paper.

3) Paper Feed Pressure Adjustment Lever
(☞p.33)

Adjusts the paper feed pressure according to paper in use.

4) Paper Feed Tray (☞p.33)

Load print paper on this tray.

5) Feed Tray Paper Guide (☞p.33)

Holds and guides paper.
Slide to fit to the sides of paper.

6) Stage Cover

Opened and closed when placing the original.

7) Stage Cover Pad (☞p.257)

8) Stage Glass (☞p.41, ☞p.257)

Place the original face-down.

9) Control Panel (☞p.22, ☞p.23)

Press the keys to perform various print operations.

10) Display (☞p.24 ~p.30)

Displays various screens needed for print operations.
Touch the buttons on the screen to execute various print operations.

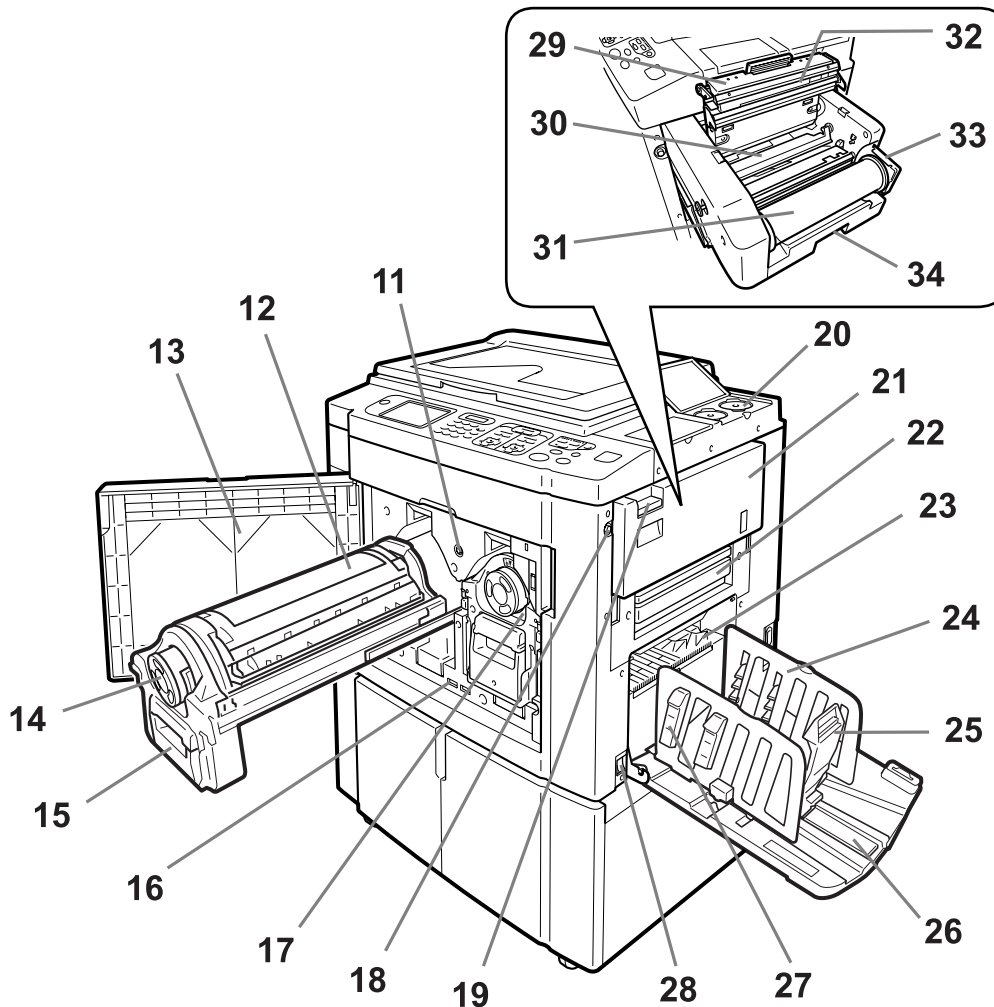

- 11) Print Cylinder (Drum) Release Button (p.250)**
Unlocks the Print Cylinder (Drum) for removal.
- 12) Print Cylinder (Drum) 1 (p.250)**
- 13) Front Cover**
- 14) Ink Cartridge (p.246)**
- 15) Print Cylinder (Drum) Handle (p.250)**
- 16) Counter**
Counts the number of copies (total print counter) and the number of made masters (master counter).
- 17) Print Cylinder (Drum) 2 (p.250)**
- 18) Master Making Unit Release Button (p.243)**
Unlocks the Master Making Unit for removal.
- 19) Master Making Unit Removal Lever (p.243)**
Grasp the lever to open Master Making Unit Removal cover.
- 20) Ink Cartridge Cap Holder (p.247)**
Secure the Ink Cartridge cap.
- 21) Master Making Unit Removal Cover (p.243)**
Once the cover is open, the Master Making Unit can be removed.
- 22) Master Disposal Box 2 (p.248)**
- 23) Paper Jumping Wing (p.122)**
Automatically adjusts to keep printed paper neatly stacked.
- 24) Receiving Tray Paper Guides (p.35)**
Aligns printed paper neatly.
Slide according to the width of paper to be printed.
- 25) Paper Stopper (p.35)**
Slide to adjust to the length of print paper size.
- 26) Paper Receiving Tray (p.35)**
Printed copies are output to this tray.
- 27) Paper Arranger (p.35)**
Press to open for aligning printed paper.
- 28) Power Switch (p.33)**
- 29) Master Making Unit Cover (p.243)**
Open and close to install Master Roll.
- 30) Master Guide Flap (p.244)**
- 31) Master Roll (p.243)**
- 32) Thermal Print Head (p.257)**
- 33) Master Roll Holder (p.244)**
- 34) Master Making Unit Lever (p.243)**
Use the lever to pull out the Master Making Unit.

Optional Devices

Auto Document Feeder AF-VI:II

The Feeder can hold approximately 50 sheets of the original sheets (64 g/m²). Place the original face-down. (☞ p.41)

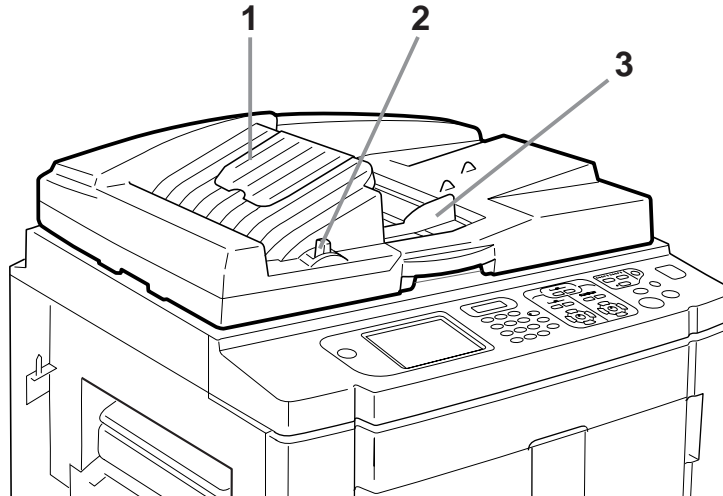

- 1) ADF Original Receiving Tray**
Scanned originals are ejected into this tray.
- 2) ADF Original Release Lever (☞ p.269)**
If an original is jammed, pull this lever to the right to eject from the ADF unit.
- 3) ADF Original Guide**
Slides and adjusts to the width of the original to hold together.

Auto Document Feeder DX-1

The Feeder can hold approximately 50 sheets of the original sheets (64 g/m²). (☞p.41)

Both sides of the original can be scanned automatically. Select the side (front or reverse) to be scanned. (☞p.164)

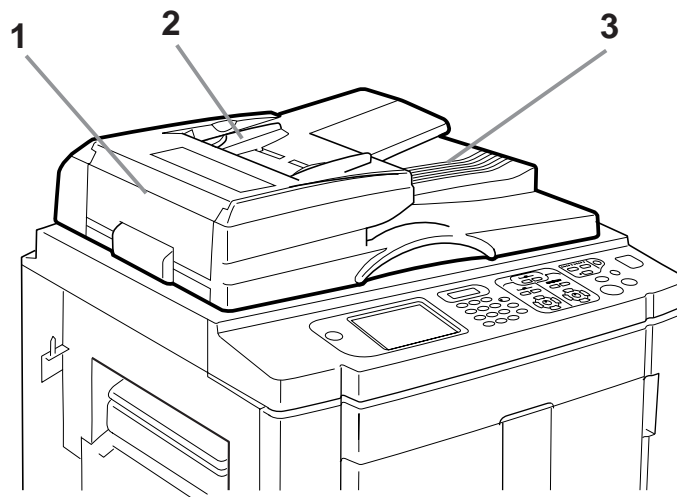

- 1) Auto Document Feeder Cover (☞p.270)**
Open to remove jammed or misfed originals from the ADF unit.
- 2) ADF Original Guide**
Slides and adjusts to the width of the original to hold together.
- 3) ADF Original Receiving Tray**
Scanned originals are ejected into this tray.

Control Panel

The Control Panel features permanent keys such as  and . It also has a large-size display that shows various messages and function buttons.

This section introduces hardware Key names and functions, as well as the display window and its functions.

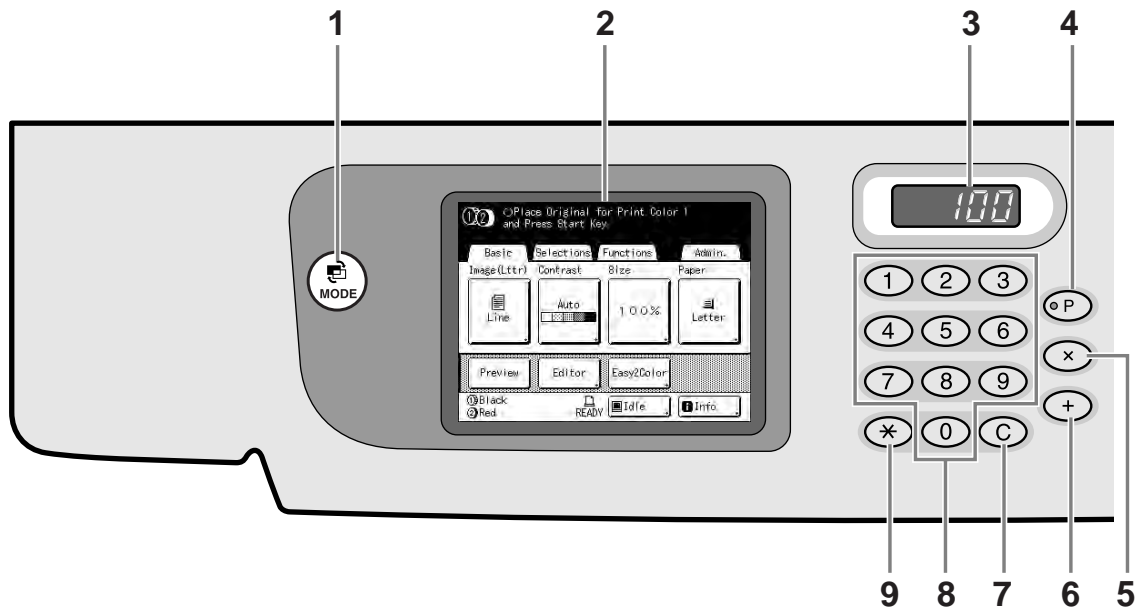

1) Mode Key

Use to change modes.

2) Display (p.24 ~p.30)

3) Print Quantity Display

Displays the number of copies, or numeric values entered for various settings.

4) P Key (p.136)

Use to retrieve stored programs. The indicator on the key lights when set.

5) xKey (p.136)

Use to move between fields in setup screens, or set up programed printing.

6) + Key (p.136)

Use to move between fields in setup screens, or set up programed printing.

7) C Key

Cancels entered numerical values, or reset the counter to 0.

8) Print Quantity Keys (0 to 9 Keys)

Use to enter the number of copies, or the numerical values for various settings.

9) * Key (p.136, p.150)

Use to move between items in a setup screen, or retrieve stored memory.

10) Print Speed Adjustment Keys/Indicator (p.112)

Select the print speed from five levels.

The indicator above the keys shows the current speed level.

11) Print Density Adjustment Keys/Indicator (For Cylinder (Drum) 1, For Cylinder (Drum) 2) (p.114)

Select the print density from five levels.

The indicator above the keys shows the current density level.

12) Print Position Adjustment Keys/Indicator (For Cylinder (Drum) 1, For Cylinder (Drum) 2) (p.115)

Adjust the print position in the vertical direction (within $\pm 19/32$ " (± 15 mm)) and/or in the horizontal direction (within $\pm 3/8$ " (± 10 mm)) after creating a master.

The indicator above the keys shows the offset amount from the center.

To clear the offset amount, press .

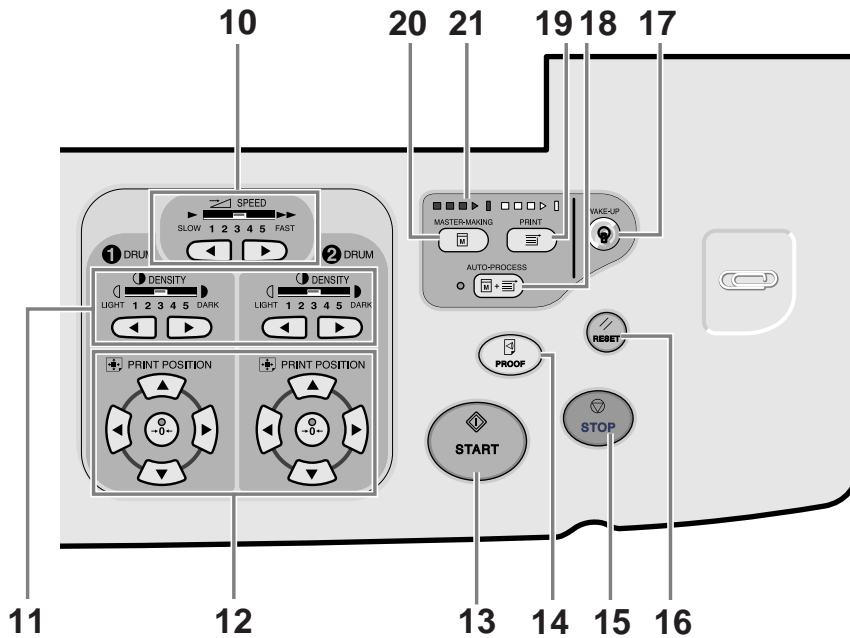

13) Start Key

Starts master-making or printing process or executes specified operations.
The key is lighted only when the key is active.

14) Proof Key (p.118)

Use when you want to check print result after adjusting the print position, for example.
This allows you to print proof copies without affecting the value on the Print Quantity Display.

15) Stop Key

Stops current operation in progress. During the master-making procedure, the machine will not stop until the master-making process is completed.

16) Reset Key

Returns all settings to the initial settings.

17) Wake-Up Key

Wakes up the printer in Energy Saving mode.

18) Auto-Process Key (p.83)

Performs non-stop operation from master-making through printing. When activated, the indicator besides the key lights.

19) Print Key

Makes the printer be ready for printing.

20) Master-Making Key

Makes the printer be ready for making masters.

21) Progress Arrows

Indicates master-making and printing progress status.

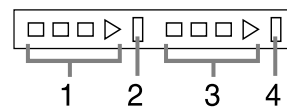

- 1) Master-Making Indicator
- 2) Master-Making Stop Bar
- 3) Print Indicator
- 4) Printing Stop Bar

Ready to make a master (Auto ON): when 1 is blinking
Ready to make a master: when 1,2 are blinking
Ready to print: when 3,4 are blinking
The indicator increases one bar at a time from the left, indicating the progress of the current master-making or printing job.

- If a master-making or printing job is halted, the progress bar stays lit at that position. (Ready for resume)

Display

The Screens and their Various Stages

When the power is turned on, after a brief display of the start-up screen, the initial screen appears.

Power ON



Start-Up Screen (Ex.)



Note:

- Start-Up Screen settings
Select **[Start-Up Screen]** on the Admin. screen.



Initial Screen (Ex.)

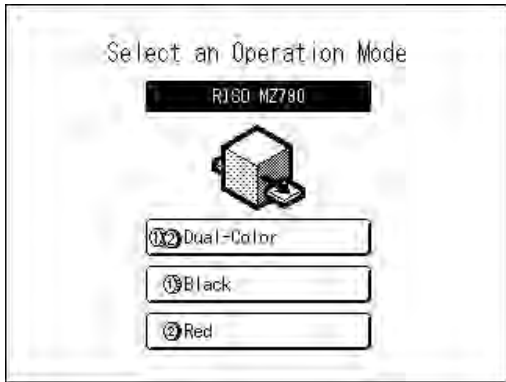

The Mode Screen is normally displayed as shown in the diagram on the left.

Note:

- When the optional Document Storage Card DM-128CF or RISO Controller PS7R is installed and a Linked Printer (sold separately) is connected, the Mode Screen is displayed as shown below.

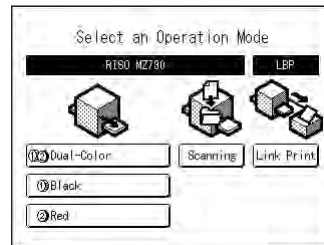

Selecting a Mode

Touch the Mode button on the Mode Screen to view the basic screens of the various modes.

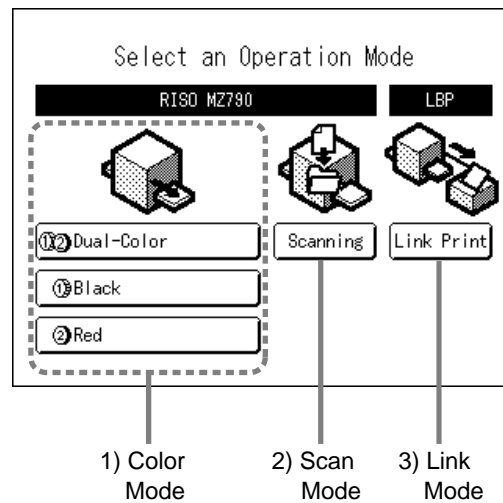

1) Color Mode

Select the print type (2-Color Print/1-Color Print (Cylinder (Drum) 1 only or Cylinder (Drum) 2 only)) to display the Operation Selection Screen (MasterMake/Printing).

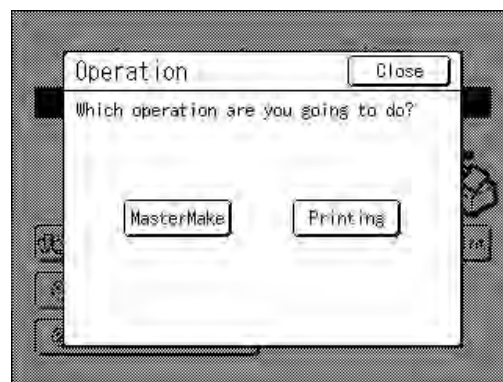

- Touch **[MasterMake]** to display the Master Making Basic Screen.



- Touch **[Printing]** to display the Print Basic Screen.

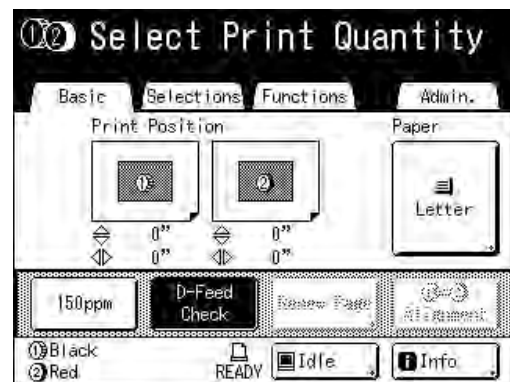

Note:

- The diagram above shows the basic screen for 2-Color printing. The screen for 1-Color printing is different.

2) Scan Mode (Option)

Touch [**Scanning**] to display the Scan Basic Screen.

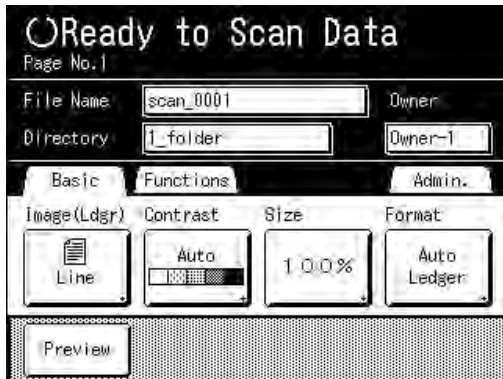

Note:

- See “Storage and Scan Modes” (p.194) for information about Scan Mode.

3) Link Mode (Option)

Touch [**Link Print**] to display the Link Basic Screen.

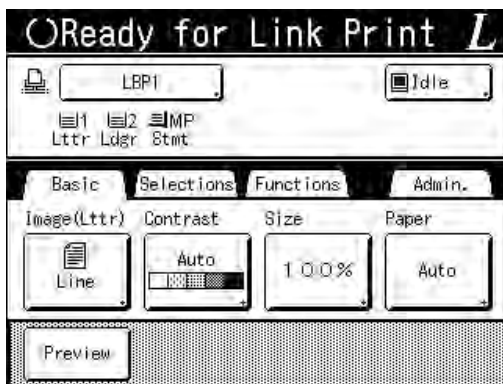

Note:

- Refer to “When using a Linked Printer (sold separately)” (p.222) for information on connecting and using a Linked Printer (sold separately).

Note:

- Pressing the  will open the Mode Screen no matter which screen you are currently on.

Basic Screen Layout

The name and function of each area of the basic screens are explained below. The display of the basic screen differs depending on whether you are scanning a paper document or printing from a computer.

Note:

- The display for each basic screen differs depending upon the mode.

Scanning and Printing from a Paper Document



1) Message Area

Displays the printer status and operational instructions. If functions such as Program (p.132) or Ink Saving are used to print, the program information and/or function icons are displayed.

2) Tab Area

Touch a tab to display its screen.

3) Functions Area

The main functions for master-making/printing steps. Each button shows the current setting. Touch the button to make changes.

4) Direct Access Area

Up to four buttons can be selected in advance. Use this area to store most frequently-used functions. You can make selections on the Admin. screen.

p.182

5) Status Area

Displays the current status of the machine and the Linked Printer (sold separately).

/ : Color of the currently installed Print Cylinders (Drums).

: Current status of the Linked Printer.

(A Linked Printer must be specified in the Admin. screen first. Otherwise, it will not be displayed.)

- **[ERROR]**: Error in network, etc..
- **[- -]**: Linked Printer information cannot be retrieved.
- **[READY]**: Linked Printer is ready

: Status of data sent from a computer.

Touch to display the list of data being received.

- **[Idle]**: Ready to receive data
- **[Data-Map]**: Processing data for printing.
- **[Pause]**: Ready for output.
- **[Error]**: Error in data transmission.
- **[Blocked]**: Cannot receive data

Info : Touch to display information (consumables information, Disposable Box Space, Print Cylinder (Drum) information, date/time).

p.242

Printing from a Computer Data



1) Tab Area ("Selections" and "Admin." tabs are disabled)

Touch a tab to display its screen.

2) Job Properties Area

Properties of the current print job is displayed.
Refers to the computer data ready for print output.

3) Job Operation Area

- **[Preview]:** Displays the master making image of the page currently awaiting creation. (Available only in the Master Making Basic Screen.)
- **[Renew Page]:** Create another master when current one is damaged or compromised, without having to download data from the computer. (Available only in the Print Basic Screen.)
- **[Skip Page]:** Stops processing the current page and moves on to process the next page.
- **[Clear All]:** Stops the current process altogether.

4) Paper Button

☞ p.82

5) Auto Print

A printing operation can be set to stop at certain points. (overrides driver settings)

6) Optional Device Area

Displays when an optional device is attached.
Touch to activate.

Note:

- When no optional device is attached, "150ppm" button is displayed.

7) Status Area

Displays the current status of the machine and its Linked Printer (sold separately).
This area shows the same information as that on the "Printing from the Original Document" screen. (☞ p.27)

Note:

- Depending upon the usage environment, some of the "Admin." features may not be available ("Admin." tab may not be displayed). Consult your dealer (or authorized service representative) for details.
- For information on other screens and their functions or settings, refer to corresponding pages.

Other Screens

◆ Selections Screen

Quickly change settings for a function or open its screen.
Up to 9 functions can be displayed for quick access. (☞ p.182)

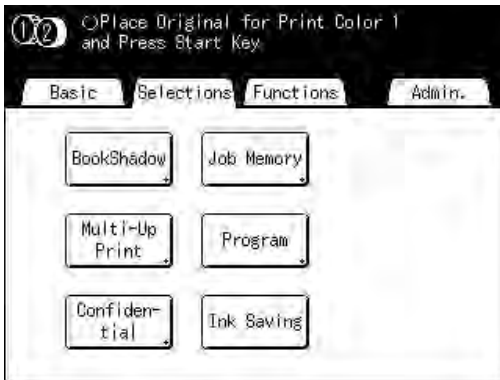

◆ Functions Screen

Access to a variety of functions.



◆ Admin. Screen

Changes the default values of various functions.

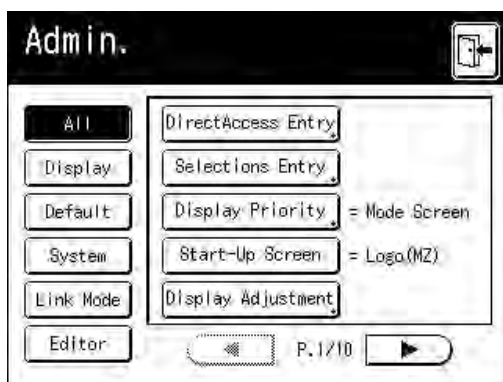
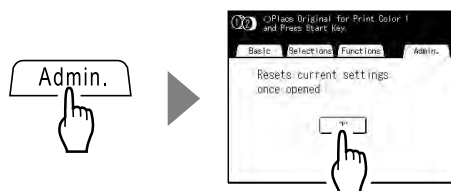

Buttons on Touch Screen

Select buttons by lightly touching with a finger.

Touch again to cancel the selection. Avoid pressing with excessive force.

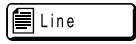

Not Selected.



Selected.



Buttons in gray cannot be selected.



Press a button with a + on the right side to expand options or display Setup screens.

Frequently Used Buttons

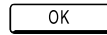

Activates/Executes a setting.

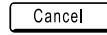

Cancels a setting.

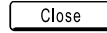

Closes a current window.



Switch pages.



Increases/decreases selected values (numbers, location, etc.).
Scrolls through screens.

Basic Operations

Preparing to Print

First, set up the Paper Feed Tray and Paper Receiving Tray of the machine.

Turning the power ON

1 Turn the power ON.

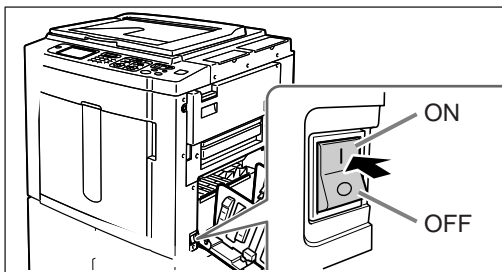

2 Select a mode.

This example is for “Dual-Color Printing”.

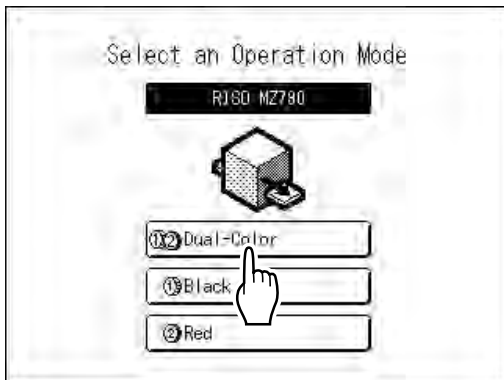

3 Touch [MasterMake] on the Operation Selection Screen.

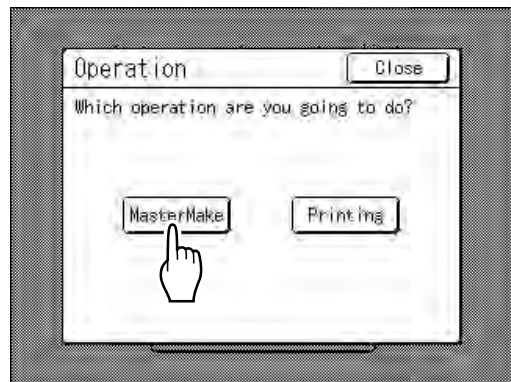

The Master Making Basic Screen appears.

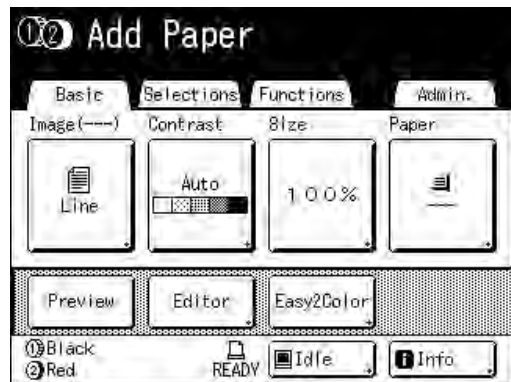

Setting up the Paper Feed Tray and Loading Paper

Important!:

- Do not use unsuitable paper, or mix paper of different sizes. Doing so can cause paper jams and damage the machine. [p.14](#)

1 Open the Paper Feed Tray.

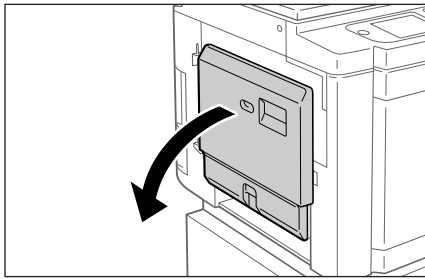

Pull the Paper Feed Tray to open until it comes to a rest.

2 Load paper.

- Place paper in the printing orientation.
- Slide the Feed Tray Paper Guides to fit to the sides of the paper. Then turn the right and left Feed Tray Paper Guide Levers to lock the guides.

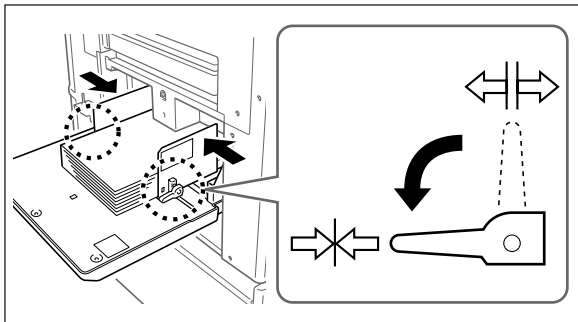

⇄ : Unlock
 ⇄✕⇄ : Lock

Important!:

- Make sure that the Feed Tray Paper Guides fit tight up against the paper. Failure to do so can produce undesired results.

Note:

- Custom size paper must be registered on the Admin. screen before use. [p.186](#)
 Failure to do so may create an incomplete master.

3 Select the paper feed pressure.

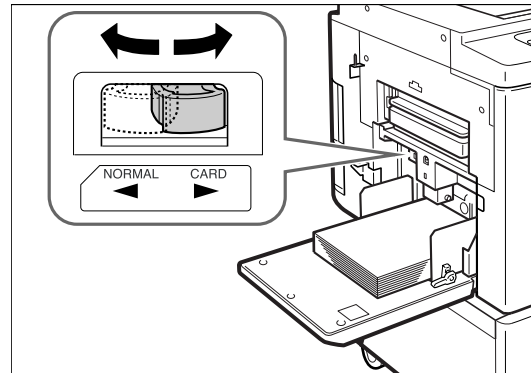

Position the Paper Feed Pressure Adjustment Lever according to the finish of the paper.
 NORMAL: For standard paper
 CARD: For thick or smooth-surface paper

4 Check the Basic Screen.

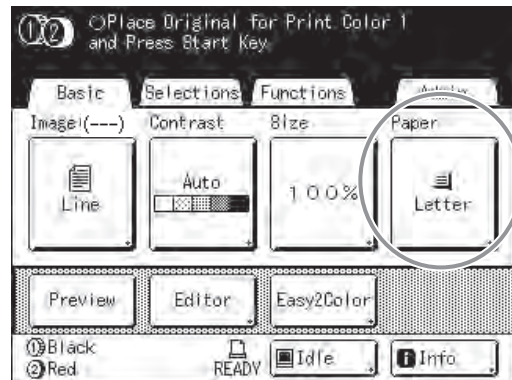

Note:

- Paper size is automatically detected. When size display shows "Custom", custom size paper is loaded, or Feed Tray Paper Guides are not properly set against the paper. Make sure that the paper fits tightly against the Feed Tray Paper Guides. When using customized paper, touch **[Paper]** and select the size. [p.82](#)

Adding or Replacing Paper

When you add paper or replace with paper of a different size at the time of printing, press the Feed Tray Descent Button to lower the Paper Feed Tray.

If you press and hold the button, the Paper Feed Tray will be lowered until you depress the button.

Important!:

- When changing to a different paper size, remember to readjust the Receiving Tray Paper Guides and Paper Stopper.
- When changing to a different quality paper, remember to adjust the Paper Feed Pressure Adjustment Lever.

Feed Tray Descent Button

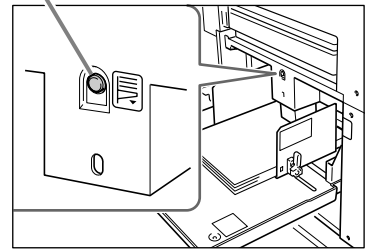

Closing the Paper Feed Tray

Before closing the Paper Feed Tray, remove the paper and widen the Feed Tray Paper Guides to the limits. Then close the Paper Feed Tray.

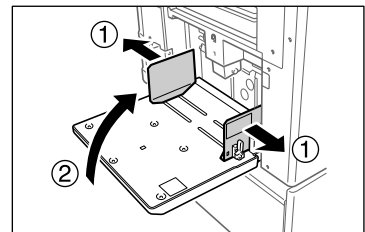

Setting up the Paper Receiving Tray

1 Open the Paper Receiving Tray.

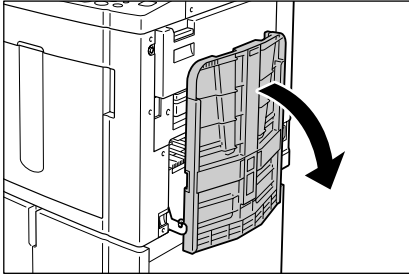

Pull the Paper Receiving Tray down until it comes to a rest.

2 Position the Receiving Tray Paper Guides.

- 1) Raise the Receiving Tray Paper Guides.
- 2) Hold their lower part and slide them to fit the paper width.

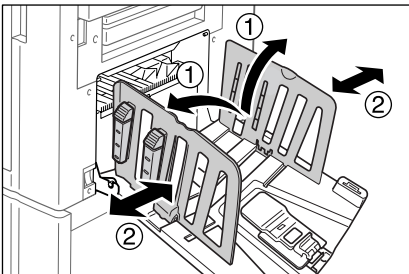

Important!:

- For thick paper such as drawing paper, position the Receiving Tray Paper Guides a little wider than the actual paper width.

3 Set the Paper Stopper.

- 1) Raise the Paper Stopper.
- 2) Slide to fit the length of the paper.

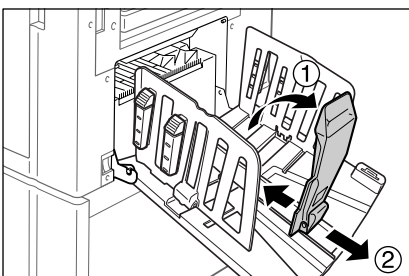

4 Adjust the Paper Arrangers.

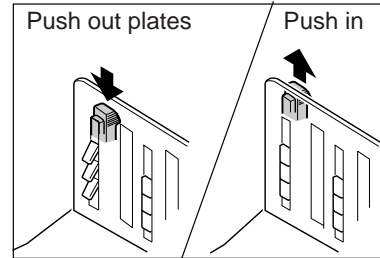

Alignment of paper is affected by sizes and strength of paper. Adjust the Paper Arrangers so that printed paper is aligned. Press the Paper Arranger to push the plates out, pull up to pull them in.

◆ For plain paper

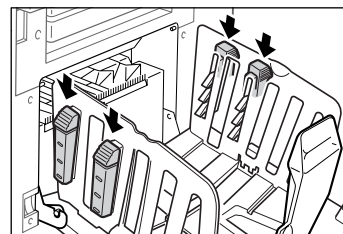

Press to open all of the four Paper Arrangers.

◆ For plain paper with images lopsided on page

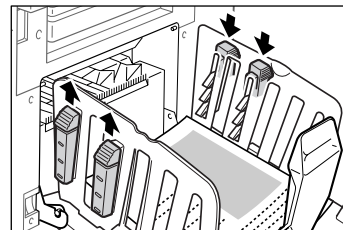

Press to open the two Paper Arrangers on the more heavily printed side.

◆ For thick paper

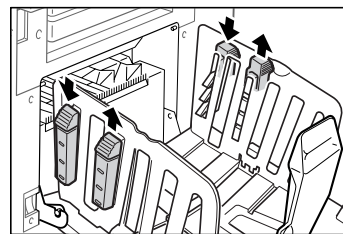

Press to open the two Paper Arrangers (right and left) closer to the machine.

Closing the Paper Receiving Tray

Remove all printed copies and follow the steps below to close the Paper Receiving Tray.

- 1) Slide the Paper Stopper to the edge of the Paper Receiving Tray.

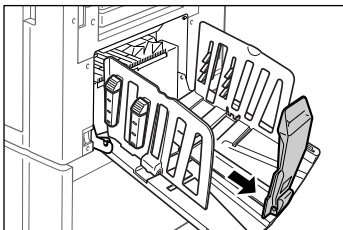

- 2) Fold in the Paper Stopper.

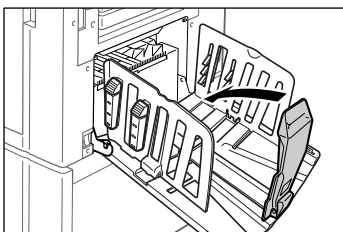

- 3) Pull up the Paper Arrangers, slide the Receiving Tray Paper Guides to the left and right as far as they will go.

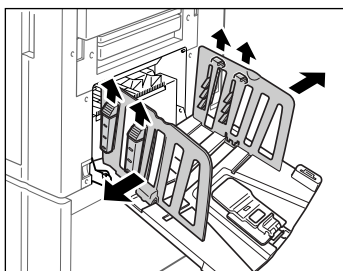

- 4) Fold in the Receiving Tray Paper Guides.

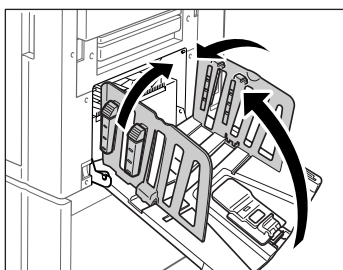



- 5) Close the Paper Receiving Tray.

Basic Process

The general print job flow for 2-Color printing is explained here.

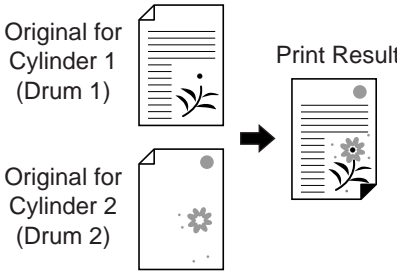
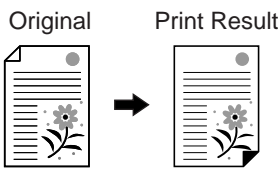
There are two methods for 2-Color printing: Preparing two originals separated by color (For Cylinder (Drum) 1 and For Cylinder (Drum) 2), or separating the colors of one original into two.

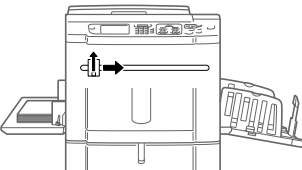
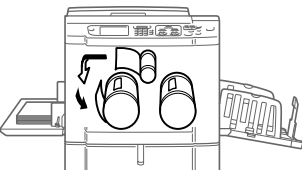
Process	Operation Flow		
	For 2-Color printing with 2 originals separated by color:	For 2-Color printing by separating the colors of a single original (when using Easy 2Color)	
	<p>Original for Cylinder 1 (Drum 1)</p>  <p>Original for Cylinder 2 (Drum 2)</p> <p>Print Result</p>	<p>Original</p>  <p>Print Result</p>	
Master-Making	<p>Place the original for Cylinder (Drum) 1.</p>  <p>Place the original on Stage Glass or in ADF unit (option).</p>		<p>Place the original.</p>  <p>Place the original on Stage Glass or in ADF unit (option).</p>
	<p>Scanning the Original</p>  <p>The scanner scans the original.</p>		
	<p>Master Making on Cylinder (Drum) 1</p>  <p>A master for Cylinder (Drum) 1 is made and wrapped around Cylinder (Drum) 1.</p>		

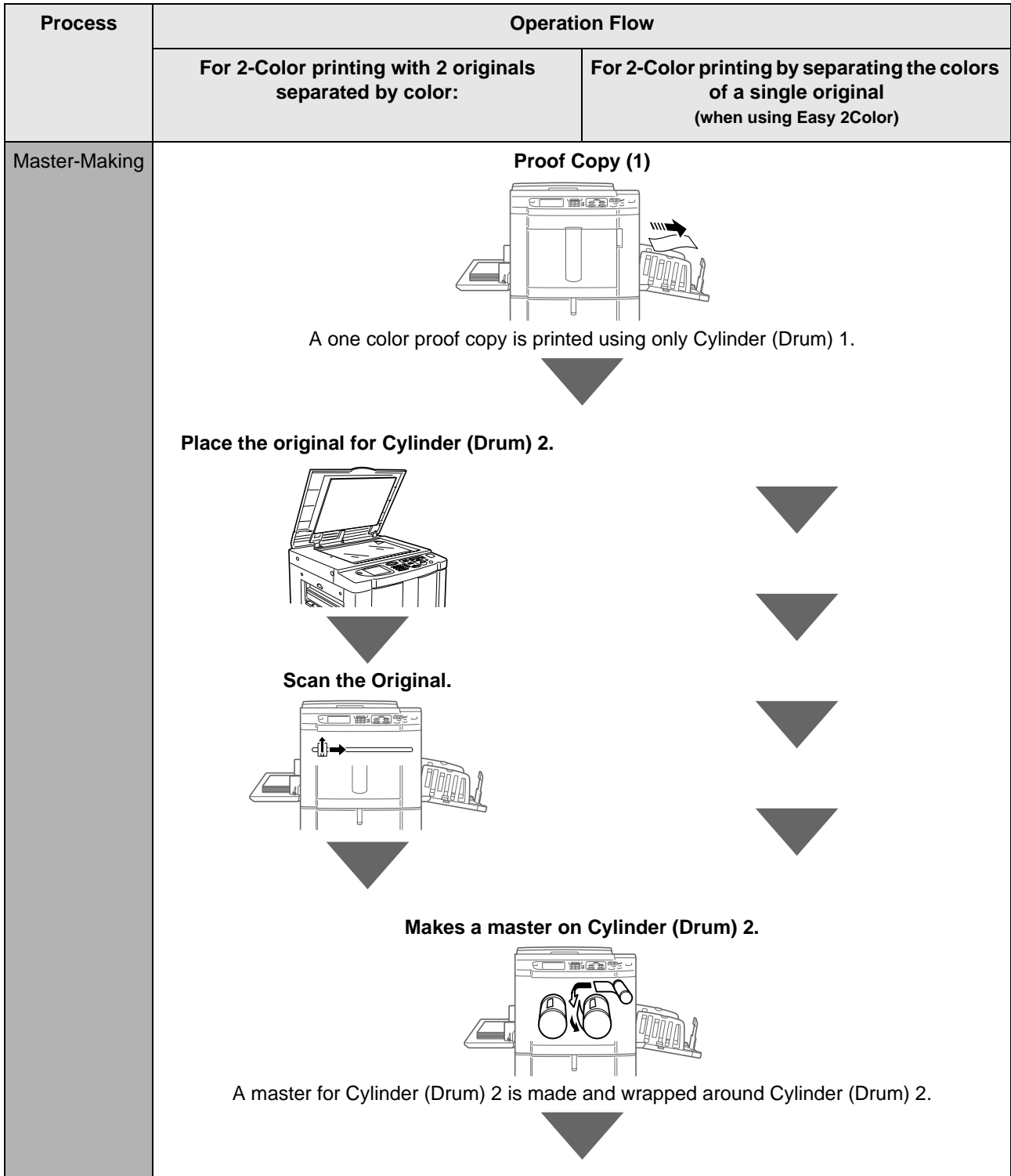

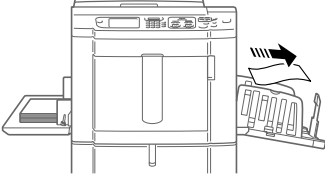
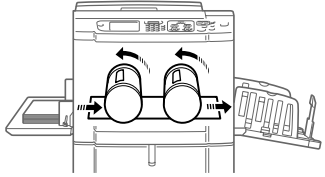
Process	Operation Flow	
	For 2-Color printing with 2 originals separated by color:	For 2-Color printing by separating the colors of a single original (when using Easy 2Color)
Master-Making	<p>Proof Copy (2)</p>  <p>A 2-color proof copy is printed.</p>	
Printing	<p>Print</p>  <p>The specified number of copies are printed.</p>	

2-Color Printing with 2 Originals

A total of 2 originals (For Cylinder (Drum) 1, For Cylinder (Drum) 2) are printed.

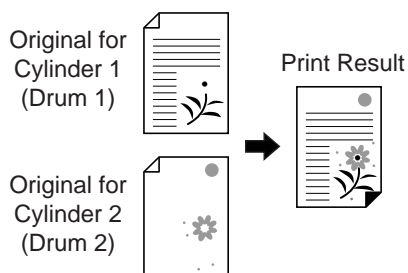



Important!:

- Use paper that is $7\frac{3}{16}'' \times 10\frac{1}{8}''$ (182 mm \times 257 mm) (B5) or larger.

1 Turn the power ON.

Note:

- When the power is OFF, both the Display and the  key are off. Turn the power ON.
- If the  key is lit, the machine is in Energy Saving mode. Press the  key to cancel Energy Saving mode.

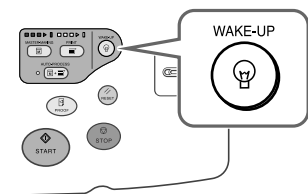

Note:

- If a basic screen other than the dual-color printing screen is showing, press the  key to display the Mode Screen.

2) Touch [MasterMake] on the Operation Selection Screen.

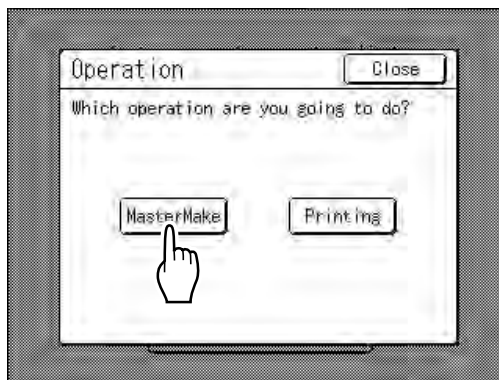

The Master Making Basic Screen appears.

2 Selecting Dual-Color Printing.

1) Touch [Dual-Color].

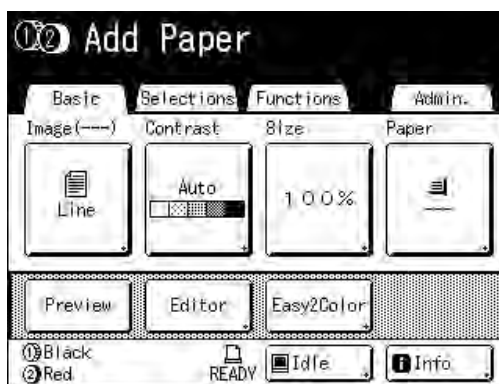
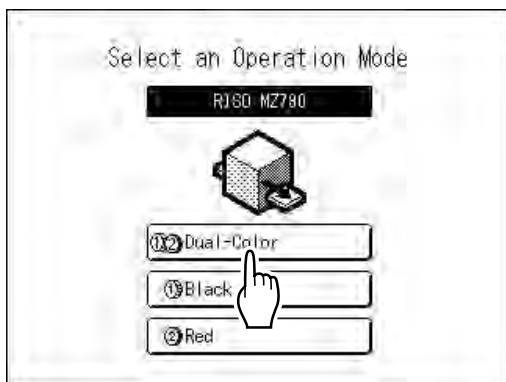

3 Load paper.

See p.33 for details on how to load the paper.

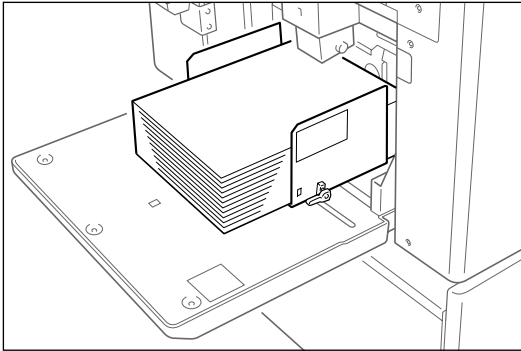

4 Set up the Paper Receiving Tray.

See p.35 for details on how to set up the Paper Receiving Tray.

5 Place the original for Cylinder (Drum) 1.

Place the original on the Stage Glass or in the optional ADF (Auto Document Feeder) unit.

◆ When placing on the Stage Glass

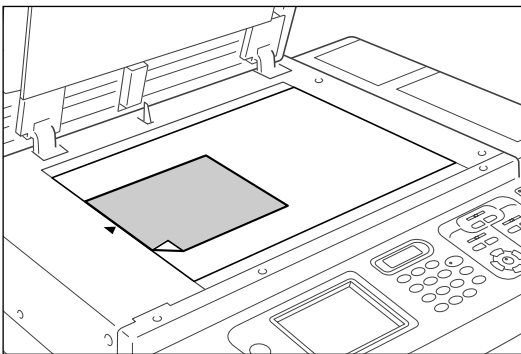

Place the original face down on Stage Glass. Align center on the top edge, and close Stage Cover.

Magazines, books, scrap books, etc. should be placed on Stage Glass.

Tip:

Using the Gauge Cover

The Gauge Cover allows you to align original images precisely on the Stage Glass even if they are not squared on the sheet. Shift the original sheet along the grid lines printed on the cover, touching it through the openings on the cover.

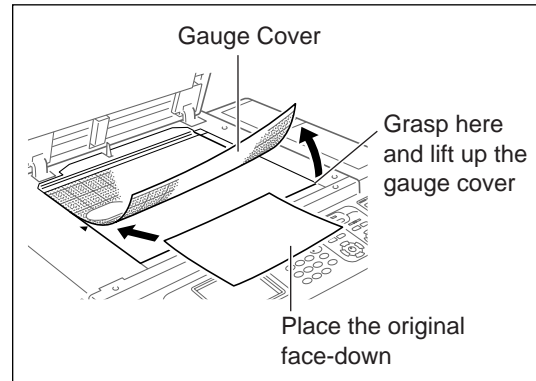

◆ Setting the Auto Document Feeder (Option)

Match the original guides to the width of the original, then push all the way to the back. In the Auto Document Feeder, the two originals can be set for cylinder (drum) 1 and cylinder (drum) 2 at once. In this case, set the original for cylinder (drum) 1 to the front side, and the original for cylinder (drum) 2 to the back side.

How to Set the Original

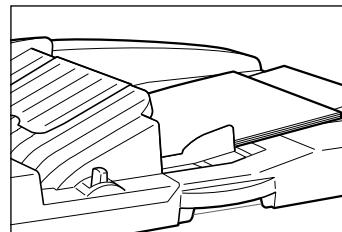

When using the Auto Document Feeder AF-VI, set the original face down.

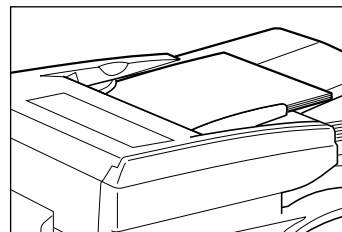

When using the Auto Document Feeder DX-1, the side of the original that is read can be specified. For details about the settings, refer to "Selecting Scanning Sides When Using the Auto Document Feeder DX-1" (p.164).

Important!:

- Make certain to read the “Size and Weight Restrictions” (p.16) concerning the originals that can be set in the Auto Document Feeder.
- When printing two copies of an original at once, the print function settings for each cylinder (drum) cannot be changed.
- When setting an original to the Auto Document Feeder, the “Auto-Process” turns “ON”.(the Auto-Process key light comes on.)When turning “OFF” the “Auto-Process”, turn off the light by pressing the Auto-Process key.

Tip:

Auto Document Feeder can have up to about 50 pages of originals set at once. (when using 64 g/m² originals).

6 Configure print functions.



In the Master Making Basic Screen, select functions as needed. See the item for each printer function for further information about print functions. If it is not displayed, press  to display the Master Making Basic Screen.

7 Press the  key.

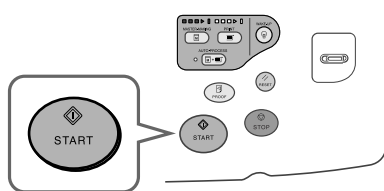

The scan of the original for Cylinder (Drum) 1 begins. Once the scan has completed, the master is made for Cylinder (Drum) 1.



Once the masters are made, one proof copy from Cylinder (Drum) 1 alone is printed, and the Master Making Basic Screen for Cylinder (Drum) 2 appears.

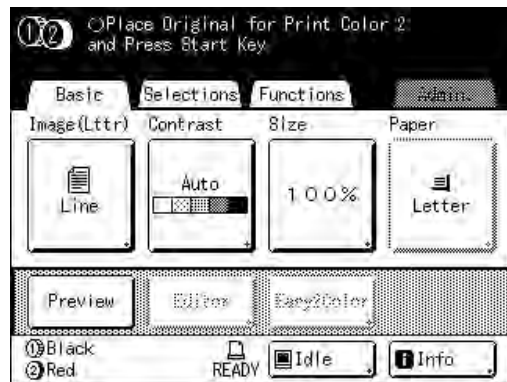

In step 5, if two originals have been placed together in the ADF unit, one proof copy from Cylinder (Drum) 1 only is printed, and the master is subsequently made on Cylinder (Drum) 2. Continue on to step 11.

Tip:

Auto Idling

When “Auto Idling” is set to ON, idling operations may occur when master-making process is initiated.

Factory default is set to idle automatically at the beginning of the master-making when the machine is inactive for over 12 hours.

To toggle “Auto Idling” ON/OFF, or to modify number of hours before activating next idling, go to the Admin. screen.

p.177

Idling can also be manually initiated when making a master.

p.160

8 Place the original for Cylinder (Drum) 2.

◆ When Placing on Stage Glass

Remove the original for Cylinder (Drum) 1 from the stage glass and place the original for Cylinder (Drum) 2 in the same way as indicated in step 5.

◆ When placing one original at a time in the ADF unit (when [Auto Process] is turned off)

You do not need to remove the Cylinder (Drum) 1 original. Place the original for Cylinder (Drum) 2 in the same way indicated in step 5.

9 Set the print functions for the Cylinder (Drum) 2 original.

You can set print functions of the original for Cylinder (Drum) 2 as needed.

If you make no settings, the same settings as the first original are applied.

Note:

- The print functions that can be set for the Cylinder (Drum) 2 original are as shown below.

◆ Auto Process (☞ p.83)

Making a master and printing in one pass

◆ Image Processing mode (☞ p.70)

Selecting Image Processing mode for the document

◆ Scanning Contrast (☞ p.77)

Selecting Scanning Contrast for the original

◆ Size (☞ p.78)

Enlarging/Reducing the Image

◆ Dot Process (☞ p.72)

Applying Dot Process to photos

◆ Tone Curve (☞ p.75)

Adjusts the gradation of a photo original.

◆ Top Margin (☞ p.105)

Cuts the top margin of an original with a margin and creates a master.

◆ Side Margin (☞ p.107)

Adjusts the side margins and creates a master.

This setting is available when the ADF (Auto Document Feeder) unit (Option) is installed.

10 Press the key.

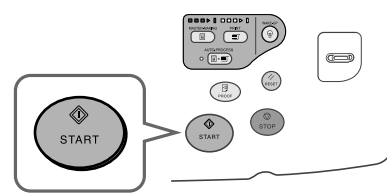

The scan of the original for Cylinder (Drum) 2 begins.

Once the scan has completed, the master is made for Cylinder (Drum) 2.

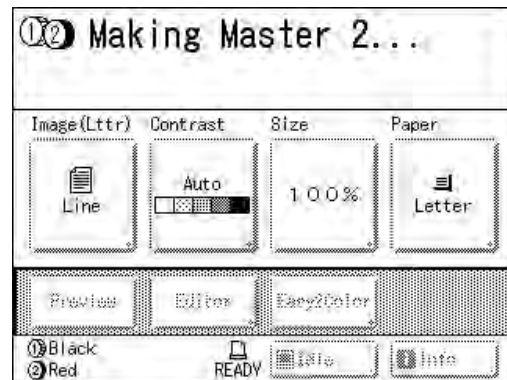

Once the masters are made, a 2-Color proof copy is printed, then the Print Basic Screen appears.

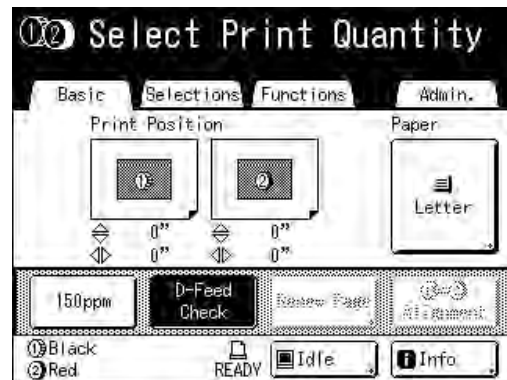

Note:

- When "Auto Process" is selected, the process will be different.
☞ p.83

11 Check the proof copy result.

When a proof copy is printed, the Print Basic Screen will be displayed automatically. Check the proof copy; e.g., print position and density. If necessary, change print position and density.

- Print Position (p.115)
- Print Density (p.114)

After adjustment, press the  key to print a proof copy.

Important!:

- When the machine has not been used for a long period of time, the print quality may suffer due to dry ink on the Print Cylinder (Drum). Press the  key to print proof copies several times.

Note:

- You can also adjust the print position, the density, and the speed while print process is in progress.

12 Enter the number of copies using the Print Quantity Keys.

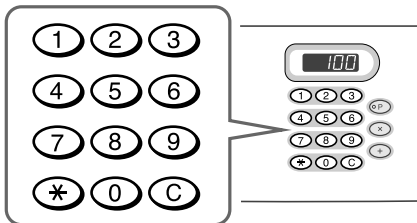

The specified number is displayed on the Print Quantity Display.

Note:

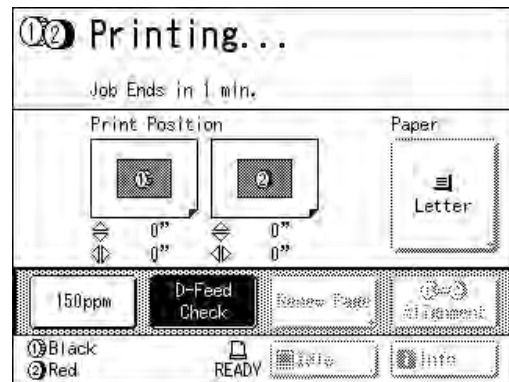
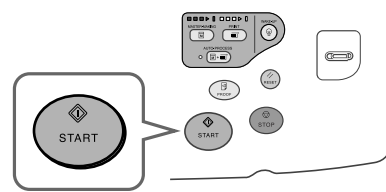

- To change the number, press the  key, then re-enter the correct number.

13 Press the key.



The specified number of copies will be printed.

Note:

- Press the  key to interrupt printing operation currently underway.
- If the machine is inactive for a certain period of time, it determines that the current job is completed, even if the actual printing is still in progress. When the machine is connected to a computer, and if another person accidentally sends a job from the computer, this causes a new master to be made, discarding the current one. To prevent this from occurring, you may set a "Reserve Period". We recommend that you activate the "Reservation" setting when printing leaflets etc. to prevent interruption. p.159
- Easily restore current settings by saving them into memory. Saved settings can be retrieved even when the  key is pressed, or after turning the power off. p.150

14 Press the key when print job is complete.

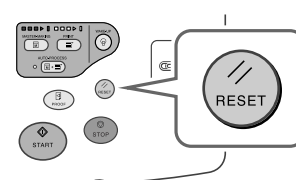

The setting returns to its default value.

Note:

- After printing is completed, the master remains on the Print Cylinder (Drum). To protect confidential documents from unauthorized duplication, use the Confidential feature to discard the master after printing.
☞ p.162

15 Remove the printed paper.

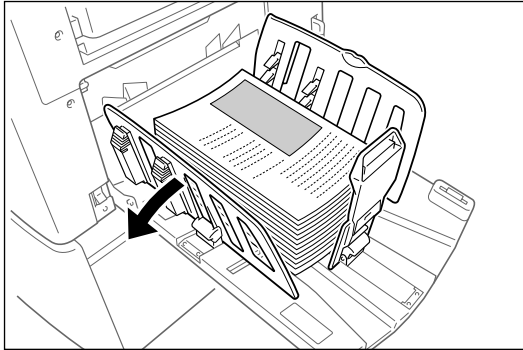

Open the Receiving Tray Paper Guides and remove the paper.

2-Color Printing with 1 Original [Easy 2Color]

One original is scanned, is divided into Cylinder (Drum) 1 and Cylinder (Drum) 2, and a dual-color print is made.

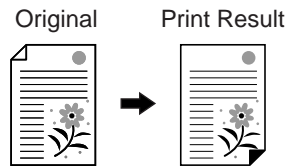

Important!:

- Use paper that is $7\frac{3}{16}$ " \times $10\frac{1}{8}$ " (182 mm \times 257 mm) (B5) or larger.

Easy 2Color Types

There are two ways of separating colors for "Easy 2Color".

◆ Separating by contrast of the original

In this separation method, the dark and light sections of the original are automatically detected. You can use 3 functions with this method: "Red Color", "Hand Writing--1", and "Hand Writing--2".

◆ Separating by specified area

Draw around the part of the original that you want to separate by using a recommended pen. You can use 2 functions with this method: "Specified Area" and "Separation Sheet".

This function cannot be used with the following functions.

- Multi-Up Print
- Size (enlargement/reduction)
- Stamp
- OneSide MasterMake
- Printing from a computer data
- 2 Up
- Book Shadow
- Auto-Link function

Important!:

- If you use "Red Color", "Hand Writing--1" or "Hand Writing--2", "Contrast" is set to "Auto" and "Image" is set to "Line".
- If you use "Specified Area" or "Separation Sheet", adjust the "Contrast".
- If you use "Specified Area", place the original on the stage glass.

Red Color

Separates the colors of an original printed in black and light red.

The master of the black portion of the original is created on Cylinder (Drum) 1, the red portion on Cylinder (Drum) 2 (cylinders (drums) are reversed if **[Sw.Color]** is selected).

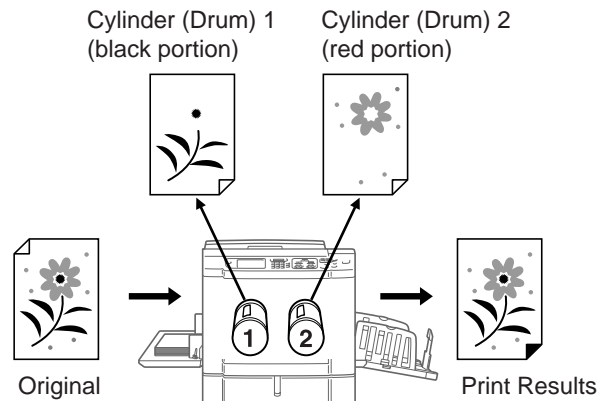

Note:

- If you are creating an original on a computer, use orange for red.

Hand Writing--1

Separates lighter images written with the recommended pen, pencil or mechanical pencil from black printed images by copier or a laser printer.

The master of the prior original is created on Cylinder (Drum) 1, the handwritten portion on Cylinder (Drum) 2 (cylinders (drums) are reversed if **[Sw.Color]** is selected).

Note:

- Do not use a ballpoint pen to write.
Red writing may be detected as black.
- Use H to 2B for mechanical pencils.

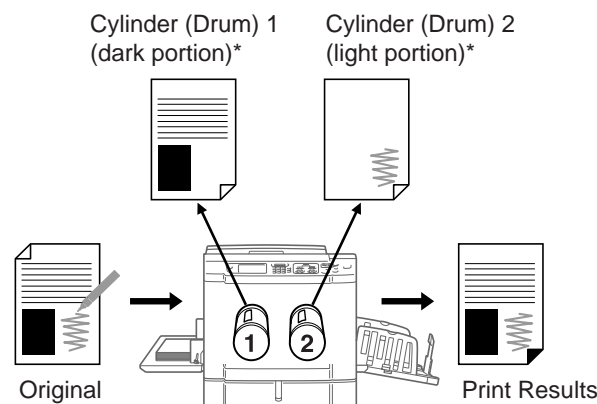

* For details about Contrast, see "About Red Color, Hand Writing--1, Hand Writing--2 Originals" (p.48).

Hand Writing--2

Separates handwriting written using the recommended pen or red pencil on originals from black printed images by a RISO printer or ink-jet printer (documents printed with a lighter shade of black, or with water-based ink, etc.). The master of the prior original is created on Cylinder (Drum) 1, the handwritten portion on Cylinder (Drum) 2 (cylinders (drums) are reversed if **[Sw.Color]** is selected).

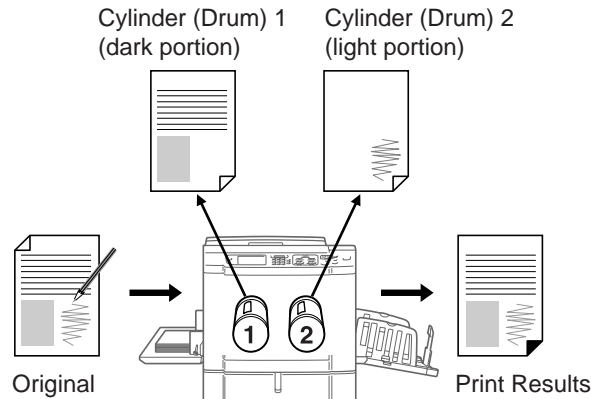

Tip:

About Red Color, Hand Writing--1, Hand Writing--2 Originals

The “Easy 2Color” function separates colors by detecting light and dark portions of the original. This function does not detect colors. The master of the dark portion of the original is created on Cylinder (Drum) 1 (black) and the light portion on Cylinder (Drum) 2 (red).

- Even if the pen is red, the contrast of the writing is dark, so it will be detected as black. In addition, if the contrast is extremely light, neither a red nor black master will be made.
- We recommend a Sans-Serif fonts of 8 point or larger for the original. For Serif fonts, please use 18 point or larger font (In case of Hand Writing--2, use 12 point or larger.). If the text is too small, it will be detected as red.
- Text that is of average contrast (not dark and not light) will be created on both a black and red master. This will cause the text edges to appear fuzzy (text will be both red and black, text will be missing, etc.).
- Contrast and tone level will determine whether photos, gradations or shaded areas are printed in black or red.

Specified Area

Separates the original that has been written directly upon with the recommended pen in the desired area. The master of the portion outside the specified area is created on Cylinder (Drum) 1, the portion within on Cylinder (Drum) 2 (cylinders (drums) are reversed if **[Sw.Color]** is selected).

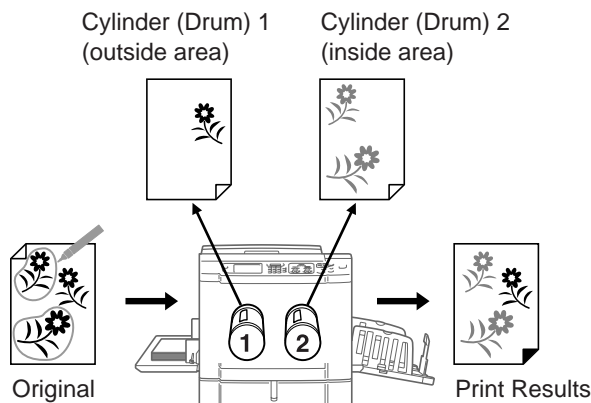

Important!:

- Use “Separation Sheet” if the original contains photos or color images.

Separation Sheet

Separates the original using a separate sheet (Area Specification Sheet) that is written on using the recommended pen for the desired area. The master of the portion outside the specified area is created on Cylinder (Drum) 1, the portion within on Cylinder (Drum) 2 (cylinders (drums) are reversed if **[Sw.Color]** is selected).

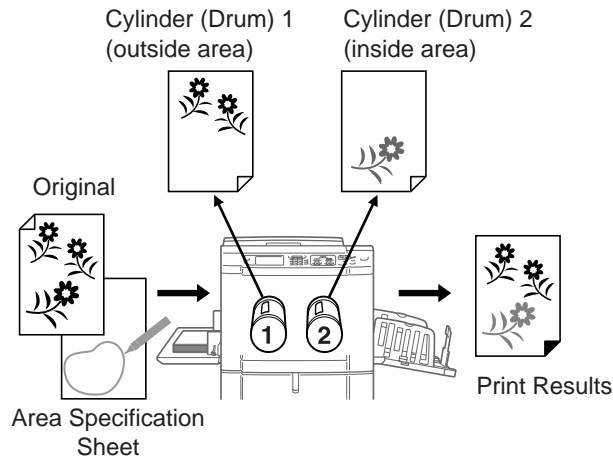

Note:

- About the Area Specification Sheet

Use the area specification sheet if you are using an original that cannot be written on. Also use the area specification sheet for separating originals with photos or color images. The Area Specification Sheet should be a white sheet of paper the same size as the original. Place the sheet on the original and draw around the area to be separated (the area to be printed in color) with the pen.

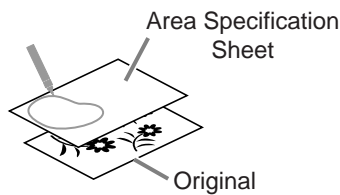

Tip:

About the Specified Area, Separation Sheet

Use the recommended pen to create the area to be specified. If you specify the area with a non-recommended pen, separation may not properly occur.

- Make sure to properly connect the edges of the area you draw with the pen. If the edges are not connected, the specified area may not be recognized.

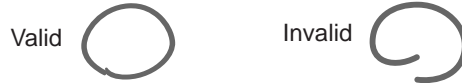

- The line width of the specified area should be between $\frac{3}{64}$ " (1 mm) to $\frac{1}{8}$ " (3 mm) (2.25 to 4.5 points). Lines less than $\frac{3}{64}$ " (1 mm) or wider than $\frac{1}{8}$ " (3 mm) will not be recognized as a specified area.

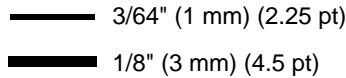

- Areas that are $\frac{3}{8}$ " \times $\frac{3}{8}$ " (10 mm \times 10 mm) or less will not be recognized as a specified area.
- If the area specified by the pen exceeds Ledger (A3) size, it will not be recognized.
- Do not create dark points on the pen line.



- Up to 20 pen areas can be created on one original. An error will occur if you select more than 20 areas.
- Do not overlap the pen areas. If the edges touch, the specified area may not be recognized. Leave $\frac{1}{8}$ " (3 mm) or more of space between pen-enclosed areas.



- Make sure the pen line is approximately $\frac{1}{8}$ " (3 mm) away from text or an image of the original. Sections within $\frac{1}{8}$ " (3 mm) of the pen line will be lost.

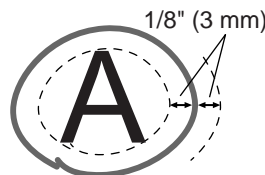

- Do not enclose an area within an area. If you do so, the inner pen area will not be recognized.

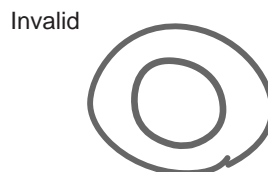



- Specified areas outside of the scanned area (size of the print paper being used) will not be separated.

Operating Procedures for Easy 2Color

1 Turn the power ON.

Note:

- If the  key is lit, the machine is in Energy Saving mode. Press the  key to cancel Energy Saving mode.

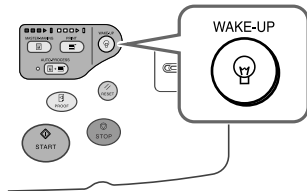

2 Select Dual-Color Printing.

- 1) Touch [Dual-Color].

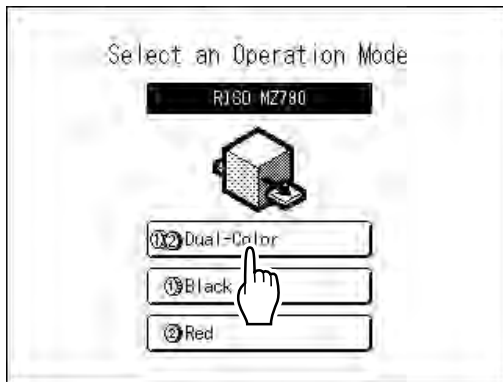

Note:

- If a basic screen other than the Mode Screen is showing, press the  key to display the Mode Screen.

- 2) Touch [MasterMake] on the Operation Selection Screen.

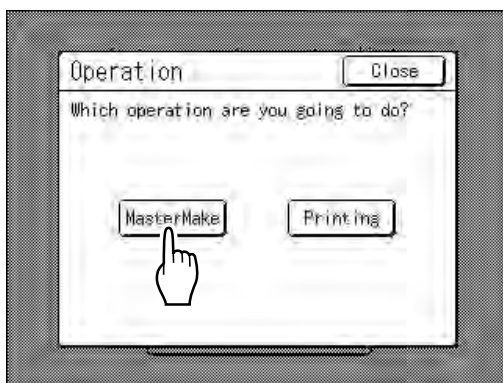

The Master Making Basic Screen appears.

3 Load paper.

See [p.33](#) for details on how to load the paper.

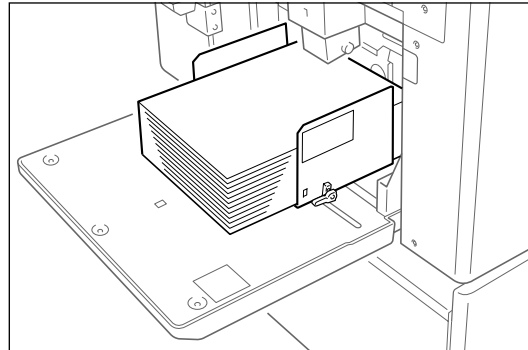

4 Set up the Paper Receiving Tray.

See [p.35](#) for details on how to set up the Paper Receiving Tray.

5 Place the original.

Note:

- The procedures for "Separation Sheet" are different.
See [p.56](#) for details.

◆ When placing on the Stage Glass

Place the original face down on Stage Glass. Align center on the top edge, and close Stage Cover.

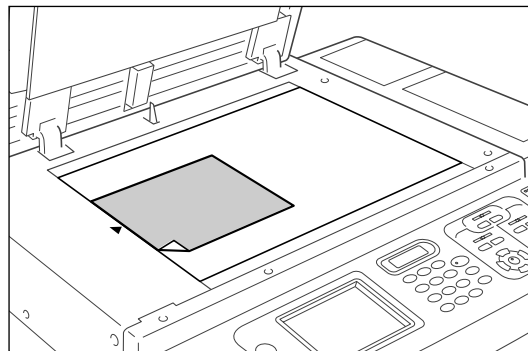

Important!:

- Do not remove the original until a 2-Color proof copy has been printed (step 9).

Note:

- Scrap books, etc. should be placed on Stage Glass.

Tip:
Using the Gauge Cover

The Gauge Cover allows you to align original images precisely on the Stage Glass even if they are not squared on the sheet. Shift the original sheet along the grid lines printed on the cover, touching it through the openings on the cover.

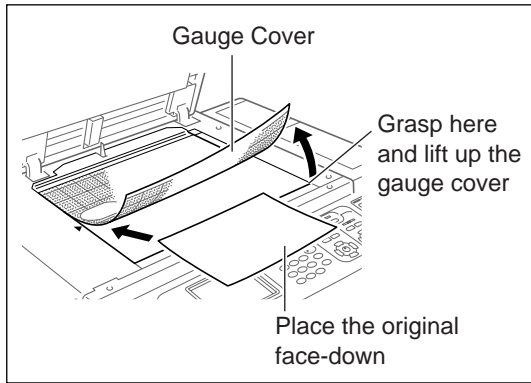

◆ **When setting the Auto Document Feeder (Option)**

Match the original guides to the width of the original, then push all the way to the back. "How to Set the Original" (p.41)

Important!:

- When using [Specified Area], set the original on the stage glass.

6 Select "Easy 2Color".

1) Touch [Functions].



The Functions screen appears.

2) Touch [Easy 2Color].

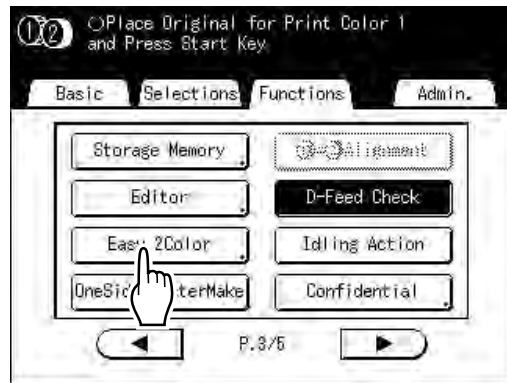

The Easy 2Color screen appears.

3) Touch the button of the separation to use.

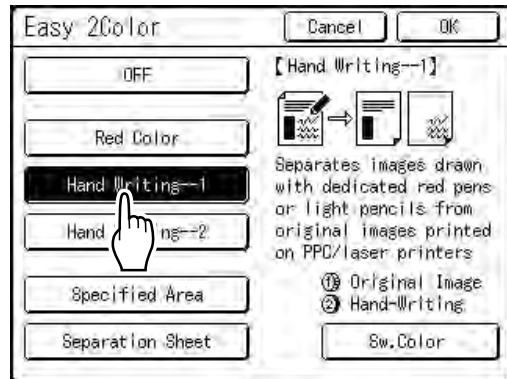

Note:

- The part for which a master is being made (either the "Original Image" portion or the "Hand-Writing" portion) is displayed in the lower right section of the screen at Cylinder (Drum) 1 (1) and Cylinder (Drum) 2 (2).

Touch [Sw.Color] to switch the color separations.

4) Touch [OK].

The Functions screen appears.

7 Configure print functions.

Make various settings as needed.
For further information, see the section for each print function.

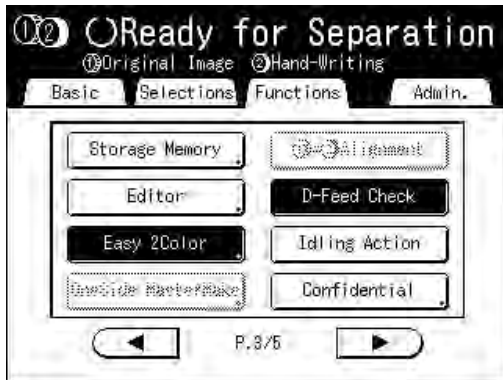

If it is not displayed, press  to display the Master Making Basic Screen.

Note:

- Set "Preview" to confirm the color separation.
p.109

8 Press the key.

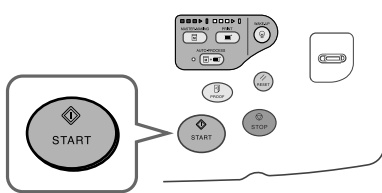

The machine scans the original, separates colors, then creates masters in a sequence.

Note:

- If you set "Preview" in step 7, the print process will temporarily stop once separation is complete.
p.109

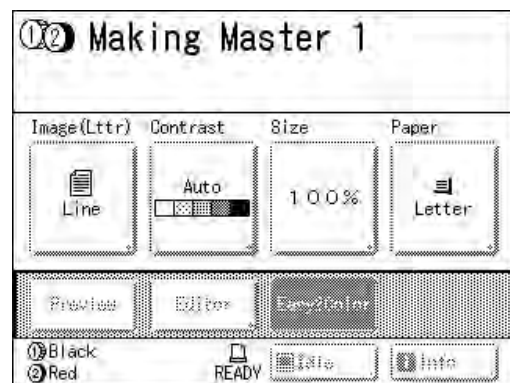
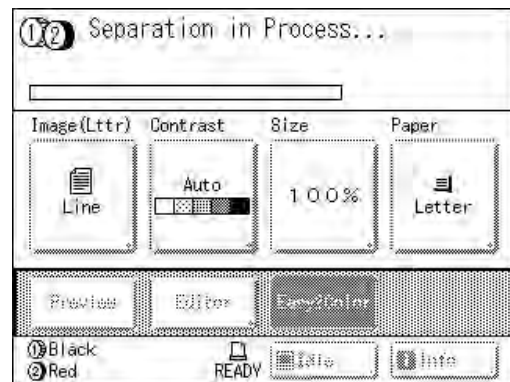
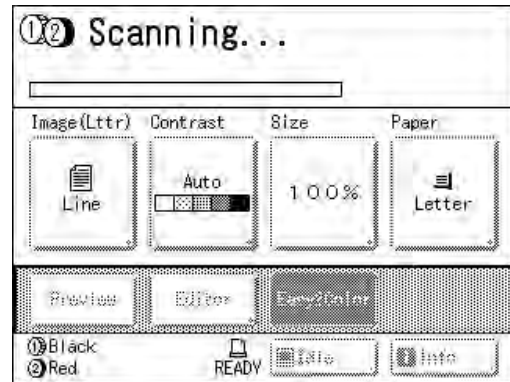

Once the master is made on Cylinder (Drum) 1, one proof copy will print from Cylinder (Drum) 1 only. A master will then be made on Cylinder (Drum) 2.



Once the master is made on Cylinder (Drum) 2, a single 2-color proof copy will print from Cylinder (Drum) 2.

When a proof copy copy is printed, the Print Basic Screen appears.

Tip:
Auto Idling

Wait for a moment if "Idling" is displayed. Once idling has stopped, making of the master begins. Factory default is set to idle automatically at the beginning of the master-making when the machine is inactive for over 12 hours.

☞ p.160

9 Check the proof copy result.

When a proof copy is printed, the Print Basic Screen will be displayed automatically. Check the proof copy; e.g., print position and density.

If necessary, change print position and density.

- Print Position (☞ p.115)
- Print Density (☞ p.114)

After adjustment, press the **PROOF** key to print a proof copy.

Important!:

- When the machine has not been used for a long period of time, the print quality may suffer due to dry ink on the Print Cylinder (Drum). Press the **PROOF** key to print proof copies several times.

Note:

- You can also adjust the print position, the density, and the speed while print process is in progress.

10 Enter the number of copies using the Print Quantity Keys.

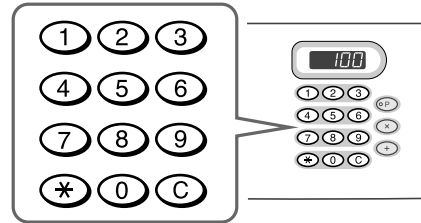

The specified number is displayed on the Print Quantity Display.

Note:

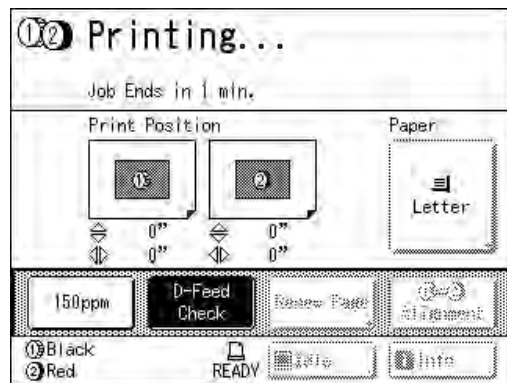
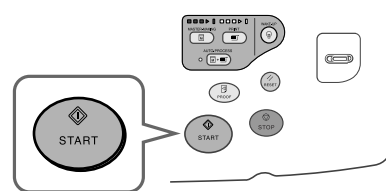

- To change the number, press the **C** key, then re-enter the correct number.

11 Press the **START key.**



The specified number of copies will be printed.

Note:

- Press the  key to interrupt printing operation currently underway.
- If the machine is inactive for a certain period of time, it determines that the current job is completed, even if the actual printing is still in progress. When the machine is connected to a computer, and if another person accidentally sends a job from the computer, this causes a new master to be made, discarding the current one. To prevent this from occurring, you may set a "Reserve Period". We recommend that you activate the "Reservation" setting when printing leaflets etc. to prevent interruption.
☞ p.159
- Easily restore current settings by saving them into memory. Saved settings can be retrieved even when the  key is pressed, or after turning the power off.
☞ p.150

12 Press the key when print job is complete.

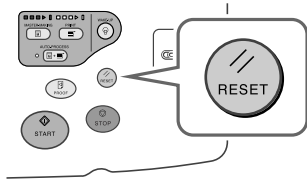

The setting returns to its default value.

Note:

- After printing is completed, the master remains on the Print Cylinder (Drum). To protect confidential documents from unauthorized duplication, use the Confidential feature to discard the master after printing.
☞ p.162

13 Remove the printed paper.

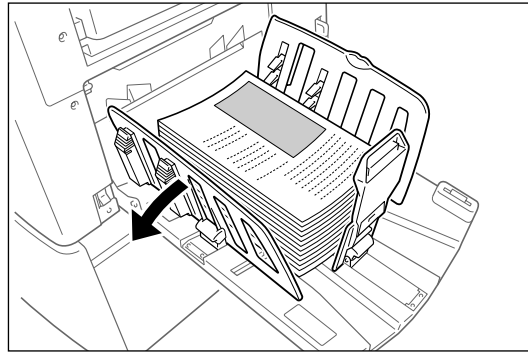

Open the Receiving Tray Paper Guides and remove the paper.

Setting an Original with the Separation Sheet

For the “Separation Sheet”, you must scan the Area Specification Sheet prior to scanning the original.

1 Place the Area Specification Sheet.

◆ When placing on the Stage Glass

Place the original face down on Stage Glass. Align center on the top edge, and close Stage Cover.

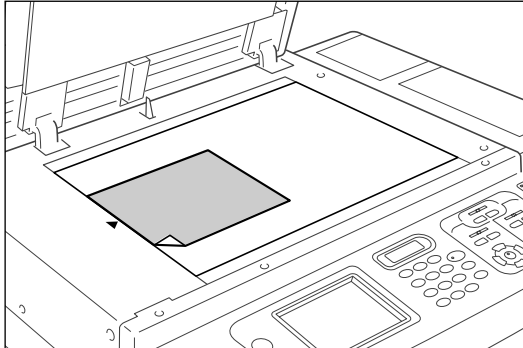

Tip: Using the Gauge Cover

The Gauge Cover allows you to align original images precisely on the Stage Glass even if they are not squared on the sheet. Shift the original sheet along the grid lines printed on the cover, touching it through the openings on the cover.

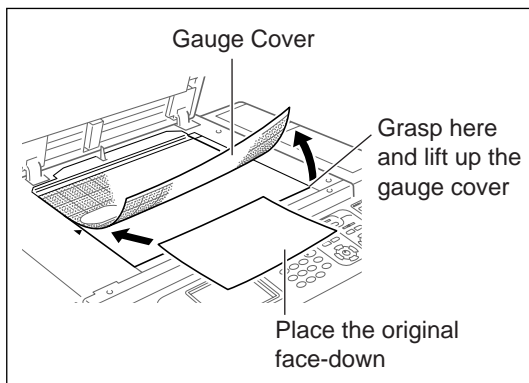

◆ When placing in the ADF unit (Option)

Place originals and then adjust the ADF Original Guides to the width of the originals. Insert the originals as far into the ADF unit as possible. (“How to Set the Original” p.41)

If you are using the ADF unit, you can set the original and the Area Specification Sheet at the same time. If you do so, place the sheet on top of the original.

Important!:

- See “Originals” (p.16) for the types of paper that you can use with the ADF unit.

2 Select “Easy 2Color”.

1) Touch [Functions].

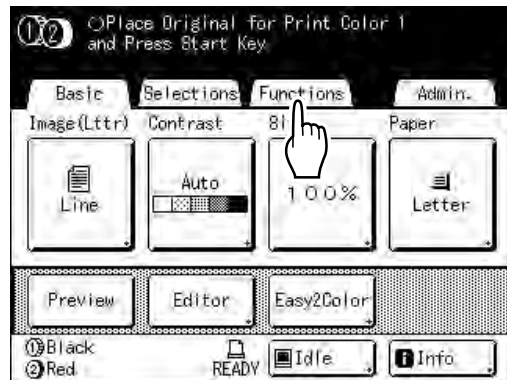

The Functions screen appears.

2) Touch [Easy 2Color].



The Easy 2Color screen appears.

- 3) Touch the button of the separation to use.

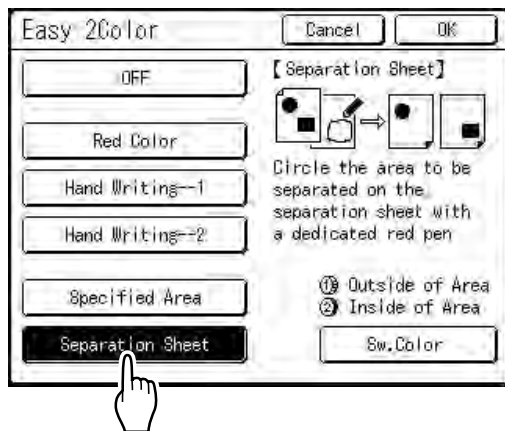

Note:

- The part for which a master is being made (either the “Outside of Area” or the “Inside of Area”) is displayed in the lower right section of the screen at Cylinder (Drum) 1 (①) and Cylinder (Drum) 2 (②). Touch [Sw.Color] to switch the color separations.

- 4) Touch [OK].
The Functions screen appears.

3 Configure print functions.

Make various settings as needed.
For further information, see the section for each print function.



If it is not displayed, press  to display the Master Making Basic Screen.

- 4 Press the  key.

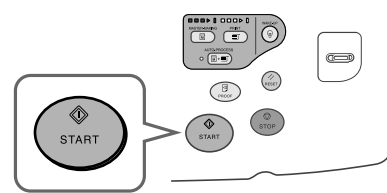

A scan of the Area Specification Sheet begins.

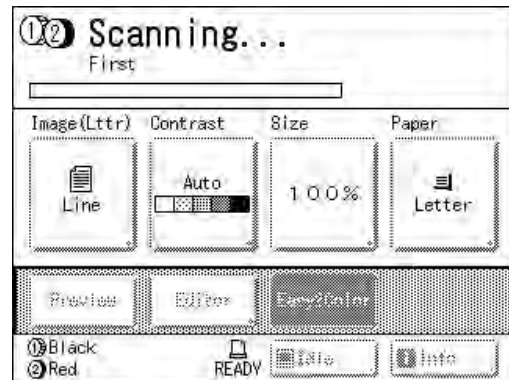

Once the scan has completed, the Master Making Basic Screen appears. The original is next scanned.

5 Place the original.

◆ **When placing on the Stage Glass**

Remove the Area Specification Sheet from the stage glass and place the original as described in step 1.

Note:

- Scrap books, etc. should be placed on Stage Glass.

◆ **When placing one sheet at a time into the ADF unit:**

Place the original as described in step 1.

◆ **When placing two sheets together into the ADF unit:**

You are not required to do anything. The original is automatically scanned.

- 6 Follow from step 8 of “Operation Procedure for Easy 2Color” (p.53).

Printing with 1-Color

Either Cylinder (Drum) 1 or Cylinder (Drum) 2 is used to print one color.



Important!:

- For 1-color printing, either Cylinder (Drum) 1 or Cylinder (Drum) 2 may be used, but we recommend using mainly Cylinder (Drum) 1.

1 Turn the power ON.

Note:

- If the key is lit, the machine is in Energy Saving mode. Press the key to cancel Energy Saving mode.

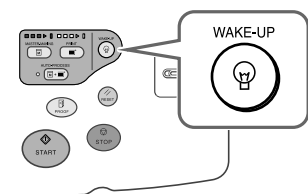

2 Select 1 Color Printing.

- Touch the button of the cylinder (drum) to use.

Note:

- The button uses Cylinder (Drum) 1 for 1-Color printing, the button uses Cylinder (Drum) 2 for 1-Color printing.
- Printing with Cylinder (Drum) 1 is explained here.
To use Cylinder (Drum) 2, see "1-Color Printing with Cylinder (Drum) 2" (p.62).

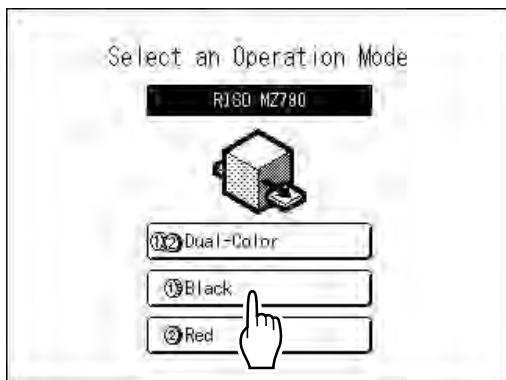

Note:

- If the 1-Color printing basic screen is not showing, press the key to display the Mode Screen.
- The colors currently set for Cylinder (Drum) and Cylinder (Drum) is displayed correctly on this screen.

- Touch **[MasterMake]** on the Operation Selection Screen.

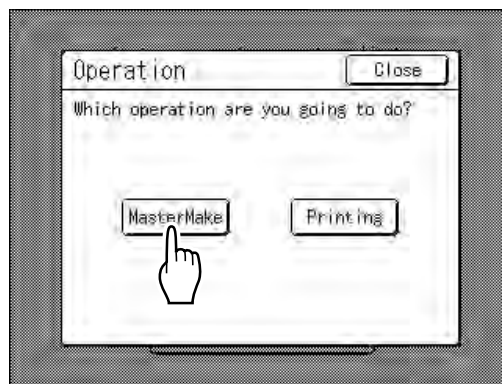

The Master Making Basic Screen appears.

3 Load paper.

See p.33 for details on how to load the paper.

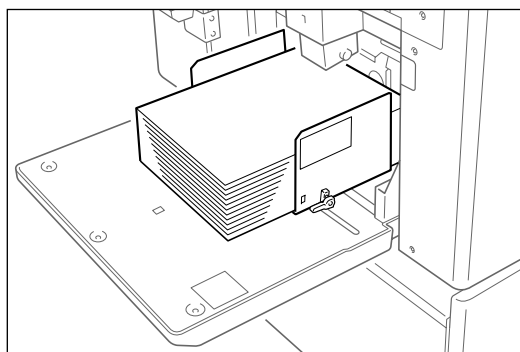

4 Set up the Paper Receiving Tray.

See p.35 for details on how to set up the Paper Receiving Tray.

5 Place the original.

◆ When placing on the Stage Glass

Place the original face down on Stage Glass. Align center on the top edge, and close Stage Cover.

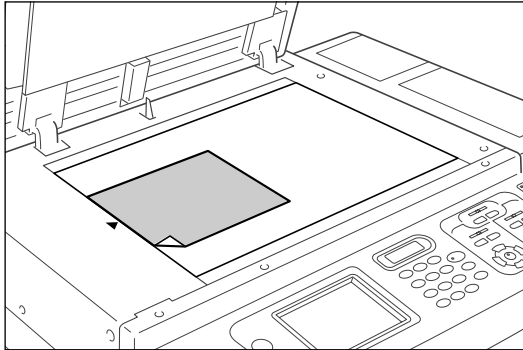

Note:

- Scrap books, etc. should be placed on Stage Glass.

Tip:

Using the Gauge Cover

The Gauge Cover allows you to align original images precisely on the Stage Glass even if they are not squared on the sheet. Shift the original sheet along the grid lines printed on the cover, touching it through the openings on the cover.

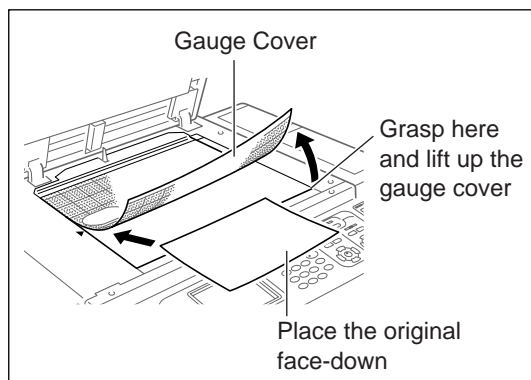

◆ When placing in the ADF unit (Option)

Place originals and then adjust the ADF Original Guides to the width of the originals. Insert the originals as far into the ADF unit as possible. ("How to Set the Original" p.41)

Important!:

- See "Originals" (p.16) for the types of paper that you can use with the ADF unit.

Note:

- Up to 50 sheets of 17-lb bond (64g/m²) paper can be placed in the ADF unit.

6 Configure print functions.

Make various settings as needed.

For further information, see the section for each print function.



If it is not displayed, press  to display the Master Making Basic Screen.

7 Press the key.

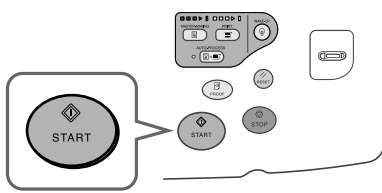

The original is scanned, separated, and a master made.



Tip:

Auto Idling

Wait for a moment if "Idling" is displayed. Once idling has stopped, making of the master begins. Factory default is set to idle automatically at the beginning of the master-making when the machine is inactive for over 12 hours.

☞ p.160

When a master is made, a proof copy will be printed.

When a proof copy is printed, the Print Basic Screen appears.

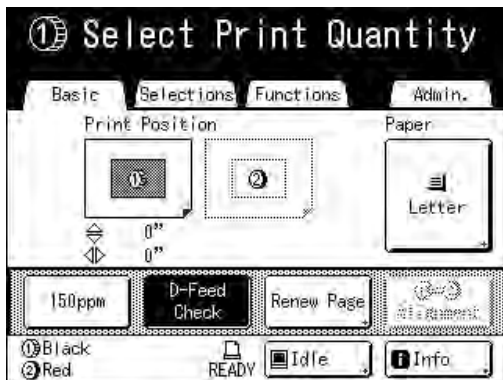

8 Check the proof copy result.

Check the proof copy; e.g., print position and density.

If necessary, change print position and density.

- Print Position (☞ p.115)
- Print Density (☞ p.114)

After adjustment, press the  key to print a proof copy.

Important!:

- When the machine has not been used for a long period of time, the print quality may suffer due to dry ink on the Print Cylinder (Drum). Press the  key to print proof copies several times.

Note:

- You can also adjust the print position, the density, and the speed while print process is in progress.

9 Enter the number of copies using the Print Quantity Keys.

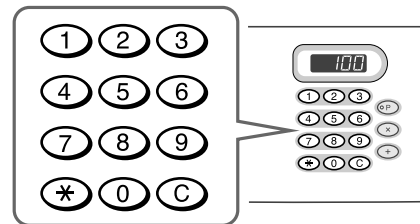

The specified number is displayed on the Print Quantity Display.

Note:

- To change the number, press the  key, then re-enter the correct number.

10 Press the key.

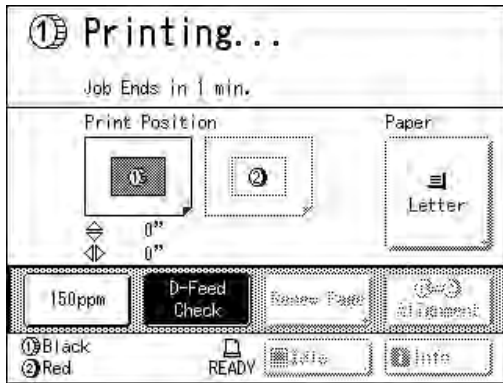
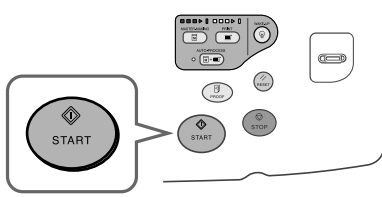

The specified number of copies will be printed.

Note:

- Press the  key to interrupt printing operation currently underway.
 - If the machine is inactive for a certain period of time, it determines that the current job is completed, even if the actual printing is still in progress. When the machine is connected to a computer, and if another person accidentally sends a job from the computer, this causes a new master to be made, discarding the current one. To prevent this from occurring, you may set a "Reserve Period". We recommend that you activate the "Reservation" setting when printing leaflets etc. to prevent interruption.
- ☞ p.159

11 Press the key when print job is complete.

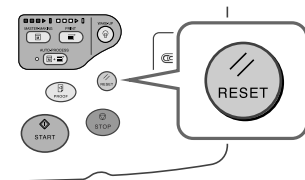

The setting returns to its default value.

Note:

- After printing is completed, the master remains on the Print Cylinder (Drum). To protect confidential documents from unauthorized duplication, use the Confidential feature to discard the master after printing.
- ☞ p.162

12 Remove the printed paper.

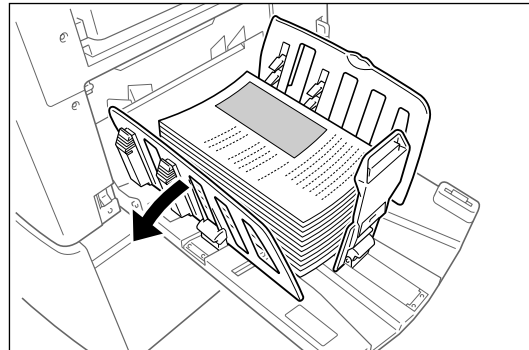

Open the Receiving Tray Paper Guides and remove the paper.

Note:

- Easily restore current settings by saving them into memory. Saved settings can be retrieved even when the  key is pressed, or after turning the power off.
- ☞ p.150

Tip:

1-Color Printing with Cylinder (Drum) 2

We generally recommend that Cylinder (Drum) 1 be used for 1-Color printing, but you can also use only Cylinder (Drum) 2. However the procedure differs slightly from Cylinder (Drum) 1. The following restrictions apply:

When removing Cylinder (Drum) 1 and using only Cylinder (Drum) 2:

The following paper sizes cannot be used.

- Standard sizes: A4 landscape, card
- Custom sizes: Paper smaller than $7\frac{3}{16}'' \times 10\frac{1}{8}''$ (182 mm \times 257 mm) (B5)
- Do not use paper smaller than $10\frac{1}{8}'' \times 14\frac{5}{16}''$ (257 mm \times 364 mm)(B4) when using the high-speed function (150ppm).

When leaving in Cylinder (Drum) 1 and only using Cylinder (Drum) 2:

- Cylinder (Drum) 1 is automatically set to "Confidential" when a master is made (the master wrapped around the current cylinder (drum) is discarded and replaced by a dummy master.
- If a non-confidential master is placed on Cylinder (Drum) 1 for printing, a warning message is displayed. Follow the instructions on the screen.

Printing from a Computer Data

[Direct Print]

The machine can receive and print the original data created on a computer. The data will be digitally processed, thus achieving high quality prints.

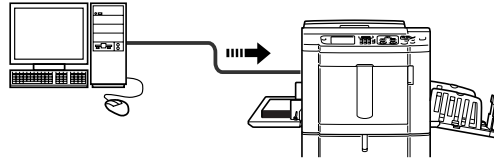

Important!:

- First, install a proper printer driver on your computer. See the RISO Printer Driver User's Guide for installation details.

Note:

- You can save original data created on a computer in the storage memory of the machine.
 ↪ p.194

Auto Process and Stop Timing

Auto Process: Auto Process is a combined automated steps of receiving data from the computer, making a master, and printing.

Stop Timing: During each process, in order to adjust settings or to change paper, you can stop the operation.

To activate "Auto Process", open the printer properties dialog box on the computer and select "Full Auto". (When "Full Auto" is activated, however, proof copy printing and subsequent adjustment steps will be disabled.)

To temporarily halt an operation during the creation of a master or during print process, select one of the following three options for "Process" in the printer properties dialog box.

- **Semi-Auto(Print)**
Halts the operation before master-making:
To change settings, to change paper and to change Print Cylinder (Drum)
- **Semi-Auto(Master)**
Halts the operation before printing:
To print proof copy, to adjust ink density, to adjust positioning and to change printing speed
- **Manual**
Stops twice; before making a master, and again before printing.

	Receive data from computer	Stop before making a master	Master Making	Stop before printing	Printing
Full Auto		---		---	
Semi-Auto(Print)		Yes		---	
Semi-Auto(Master)		---		Yes	
Manual		Yes		Yes	

Note:



- The stop timing can also be specified from the machine.
 ↪ p.68
- This manual provides only a summary of functions available when printing from a computer. See Riso Printer Driver User's Guide for further details on sending data and other settings.

Printing Computer Data

1 Make sure the machine is ON.

Check the Control Panel.

Note:

- When the power is OFF, both the Display and the  key are off. Turn the power ON.
 [p.33](#)
- If the  key is lit, the machine is in Energy Saving mode. The machine automatically wakes up from Energy Saving mode when data is sent from a computer, and it starts processing the data.

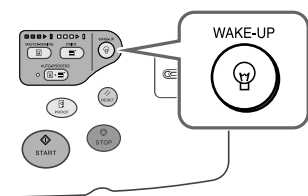

- If you are using RISORINC-NET (Option), you can check the machine status (power ON/OFF, paper settings, etc.) remotely from your computer monitor.

2 Check for printing paper.

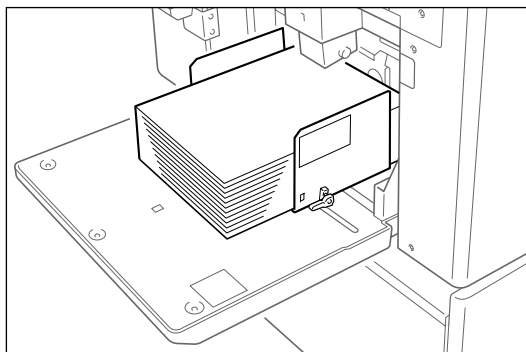

Make sure paper is loaded.

To load or to change the paper, see the following page:

[p.33](#)

After replacing with paper of a different size, adjust the position of the Receiving Tray Paper Guides and Paper Stopper.

[p.35](#)

3 Set printing options from your computer screen.

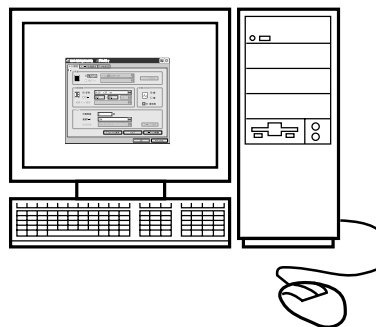

Important!:

- Make sure to uncheck the “Collate” option in the Print dialog box.
- Before printing, either perform an Idling Action ([p.160](#)) (especially when using Full Auto mode) or press the  key to print proof copies several times.

4 Click [OK] on the print dialog box.

Data is sent from the computer.



When the machine receives data, a print job automatically starts in accordance with the printer driver settings.

Continue to step 5 if you are printing in the Semi-Auto (Print) mode or in the Manual mode.

Skip to step 7 if you are printing in the Semi-Auto (Master) mode.

Skip to step 10 if you are printing in Full Auto.

Note:



- If the data contains multiple pages, all pages are printed at once.
- To manually stop a job during master-making or printing operation, press the  key. In master-making process, the machine will stop after the master is made. In the printing process, the machine will stop printing. Press the  key to resume the job.

5 Check the Display.

Check the owner name and preview to make sure that the received data is the data to be printed. Set other functions as needed.



Note:

- The following functions can be used here:
 - Preview
 - Skip Page
 - Clear All
 - Paper Size
 - Auto Print
 - Sorter
 - Job Separation
 - 150ppm
 - Renew Page
 - Rotate
 - Program (1-Color original only. “Combination” can be used when 2-Color printing)
 - Job Memory
 - Max. Scan
 - ① = ② Alignment (only for 2-Color printing)
 - D-Feed Check
 - Idling Action
 - Confidential
 - Interval
 - Auto Page Renewal
- After developing a job, press the  key or the  key to display the screen for deleting the developed job.

Tip: Job List Screen

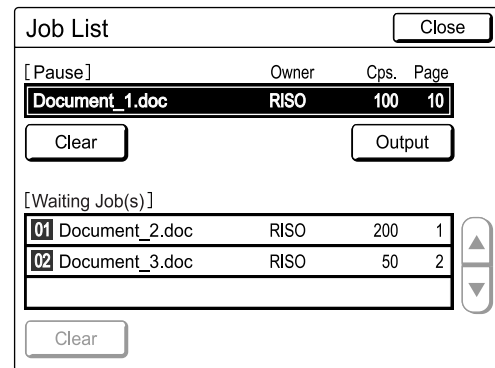

Once the data is received, touch  on the Basic Screen to review current Job List. From the Job List screen, you can initiate output for jobs pausing for output, or cancel jobs that are “Paused/Data-Mapping/Waiting”.

6 Press the key.

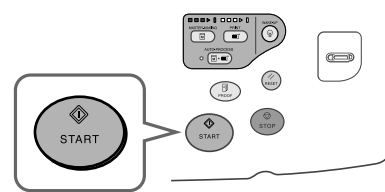

A master is made, and a proof copy will be printed.

7 Check the proof copy result.

When a proof copy is printed, the Print Basic Screen will be displayed automatically. Check the proof copy; e.g., print position and density.

If necessary, change print position and density.

- Print Position (☞ p.115)
- Print Density (☞ p.114)

After adjustment, press the  key to print a proof copy.

Important!:

- When the machine has not been used for a long period of time, the print quality may suffer due to dry ink on the Print Cylinder (Drum). Press the  key to print proof copies several times.

Note:

- You can also adjust the print position, the density, and the speed while print process is in progress.
- Entering the number of copies using the Print Quantity Keys will override the number supported by the print driver.

8 Press the  key.

The job prints using the specified printer driver settings.

When “Destination” is set to “Print Only”, original data is automatically deleted after printing.

9 For jobs with multiple pages, data from the 2nd page prints.

Data from the 2nd page on prints in accordance with “Auto Print” settings.

Subsequent steps are the same as printing from the 1st page.

Use the Received Data screen to change settings from the 2nd page on.

10 Remove the printed paper.

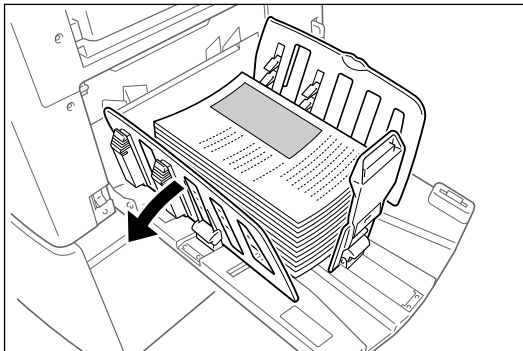

Open the Receiving Tray Paper Guides and remove the paper.

Note:

- After printing is completed, the master remains on the Print Cylinder (Drum). To protect confidential documents from unauthorized duplication, use the Confidential feature to discard the master after printing.

☞ p.162

Tip:

When using a Linked Printer (sold separately)

When “Auto Process” is activated, “Online Auto-Link” can be selected to specify output device in accordance with the print quantity.

(“Online Auto-Link” function is not available for MZ990/790U.)

☞ p.178

☞ p.222

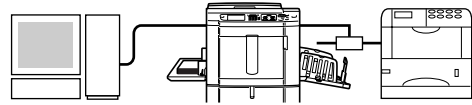

Changing Output Directions

Output can be controlled from the Master Making/Print Basic Screens.

◆ Master Making Basic Screen

• [Preview]

You can check the master making image of the page currently awaiting creation.

Note:

- In "Preview", all received original data is displayed as a master making image. Portions outside the print area do not actually print.
- [Skip Page]
Cancels a pending page, and start processing the next page. Use this button when current file has extra, unwanted pages.
- [Clear All]
Deletes all currently queued jobs. Use this button to delete a job sent by a mistake, or pending jobs no longer needed.



◆ Print Basic Screen

• [Renew Page]:

You can recreate another master when the current one is damaged without having to receive original data from the computer.

Note:

- When 2-Color printing, you can select the cylinder (drum) on which to recreate the master. When 1-Color printing, the current cylinder (drum) is used to recreate the master.
- When recreating masters for 2-Color printing, Cylinder (Drum) 1 and Cylinder (Drum) 2 can be switched by selecting "Sw.Color".
- If multiple pages exist, only the last page will be processed.
- "Rotate" can also be specified.

The confirmation screen for each respective button appears when touched. Touch [OK] to implement the instructions.



Important!:

- [Skip Page] and [Clear All] are disabled during master-making or printing processes.

Press the  key to modify directions while master-making or printing is in progress.

(In master-making process, the operation will stop after the master is made. In print process, the print job is halted.)

Note:

- Pressing either the  key or the  key while waiting for a command (under Ready to Make Master/Ready to Print screens) will delete the pending job.

Changing Stop Timing

Stop timing as set on the printer driver takes priority by default. However, the settings can be changed on the machine while the machine is halted.

Note:

- If “Auto Print” is set to ON on the machine driver, press the  key to stop the operation and to make changes.

1 Touch the “Auto Print” function button.

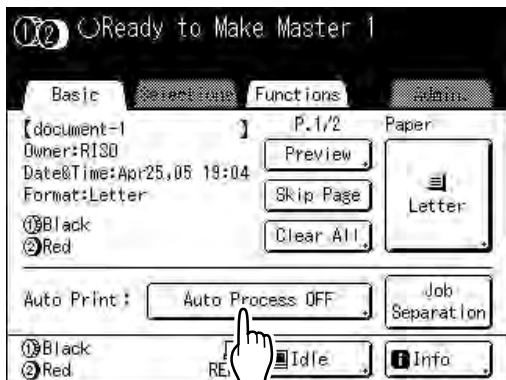

The Auto Print screen appears.

2 Select the desired function.



- **[ON]:** Makes a master then automatically prints.
- **[Semi-Auto(Print)]:** After the data is received, the operation stops before making a master.
- **[Semi-Auto(Master)]:** After a master is made and a proof copy is printed, the operation stops.
- **[Auto Process OFF]:** Stops before making a master, and then again before printing.

Note:

- See p.63 for details regarding operations after each stop.

3 Touch [OK].



The following screen appears.



Returns to Basic Screen. Auto Print setting is updated.

Functions for Master-Making

Selecting Image Processing Mode [Image]

In order to make a master best suited for the original document, select an appropriate mode depending on whether original contain only text (Line), photo, or both of them.

Note:

- Default Image Processing mode can be set on the Admin. screen.
p.173

1 Touch [Image] on the Master Making Basic Screen.



2 Select the appropriate Image Processing mode for the original.



- **[Line]:** Only text contained; e.g., text document, newspaper
- **[Photo]:** Only photos contained
- **[Duo]:** Both text and photos contained
- **[Pencil]:** pencil drawings or lightly printed documents

Touch **[Photo]** to select the type of photo.

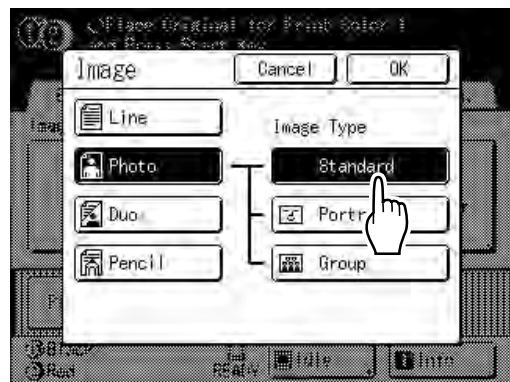

- **[Standard]:** Select for photos other than **[Portrait]** or **[Group]**.
- **[Portrait]:** Use this setting for pictures of one or two individuals from the bust up. This type of image processing is particularly good for printing photos of faces.
- **[Group]:** This setting is for group photos that are over-exposed. This process is effective for restoring facial features that have become washed out by a flash. The Group setting is not for photos with faces that are overly dark. It may be more effective to select **[Standard]** for such photos.

3 Touch [OK].

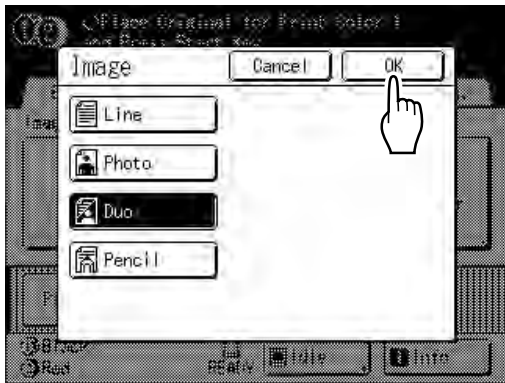

The following screen appears.



Returns to the Master Making Basic Screen.
Image Processing mode is updated.

Note:

- Some functions are not available in certain Image Processing mode settings.

	Line	Photo	Duo	Pencil
Dot Process	—	✓	✓	—
Contrast (Auto)	✓	—	—	—
Contrast (1-5)	✓	✓	✓	✓
Contrast Adj	—	✓	—	—
Tone Curve	—	✓	✓	✓

✓ : available — : not available

Processing Photos with Dot Screen

[Dot Process]

“Dot Process” function processes photo originals with dot screening in order to print more clearly. Select from four types of dot patterns.

Note:

- “Dot Process” is not available when Image Processing mode has been set to “Line” or “Pencil”.

1 Touch [Functions] on the Master Making Basic Screen.

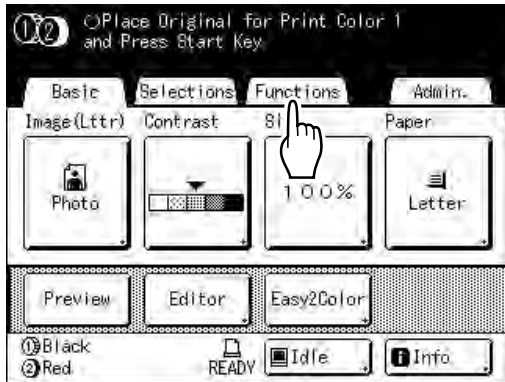

2 Touch [Dot Process].



3 Select a dot pattern.

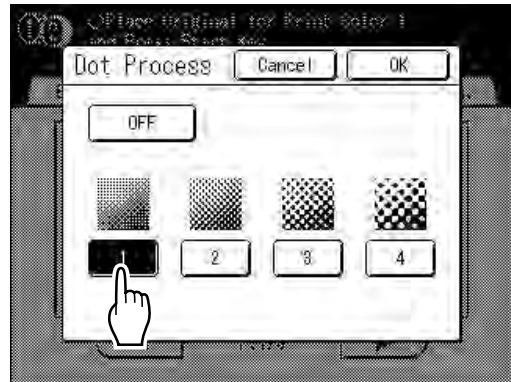

Message				
Number	1	2	3	4
Equivalent Lpi	106	71	53	34

Note:

- Touch [OFF] to cancel the “Dot Process”.

4 Touch [OK].

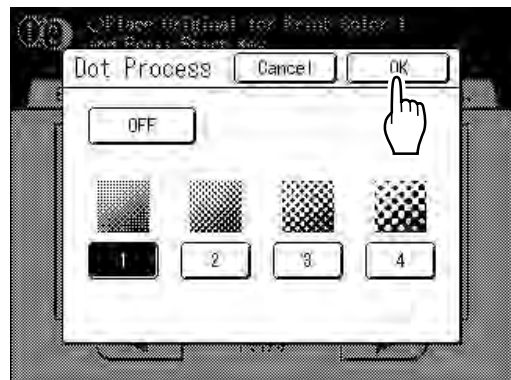

The following screen appears.



Returns to the Functions screen. Dot Process setting is updated.

Adjusting Photo Contrast [Contrast Adj]

For originals that have ill-defined photos, adjust the contrast to print more clearly. There are two ways to adjust contrast.

Important!:

- If the “Image” is set to “Line”, “Duo” or “Pencil”, “Contrast Adj” cannot be used.

1 Touch [Functions] on the Master Making Basic Screen.



2 Touch [Contrast Adj].



3 Touch the button of the contrast to use.



- **[Lighter]:** Lightens dark sections. Use this setting if the entire photo is underexposed and the target subject of the photo is ill-defined.
- **[Darker]:** Clarifies lighter portions. Use this setting if the entire photo is overexposed and the target subject of the photo is ill-defined.

4 Touch [OK].



Returns to the Functions screen. Contrast Adj setting is updated.



Adjusting Photo Gradation [Tone Curve]

You can adjust the light and shadow portions of a photo by 3 tones respectively.

Important!:

- If the “Image” is set to “Line”, “Tone Curve” cannot be used.

1 Touch [Functions] on the Master Making Basic Screen.

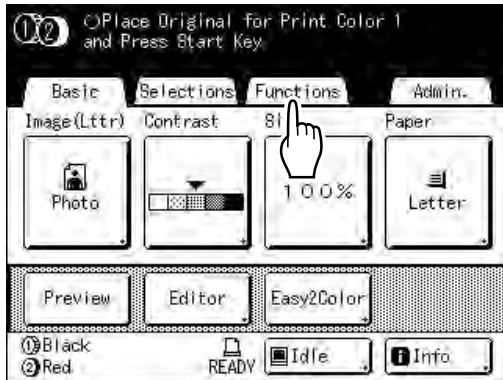

2 Touch [Tone Curve].



3 Touch the “Lights” and “Shadows” adjustment buttons.

Use [+1] or [-1] to strengthen or weaken each respectively.

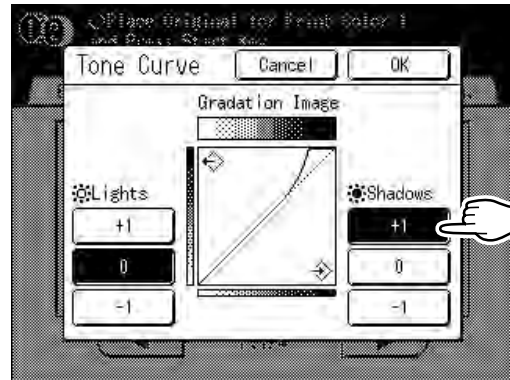

- **Lights:** Adjusts the portion of the picture most exposed to light.
- **Shadows:** Adjusts the portion of the picture least exposed to light.

4 Touch [OK].

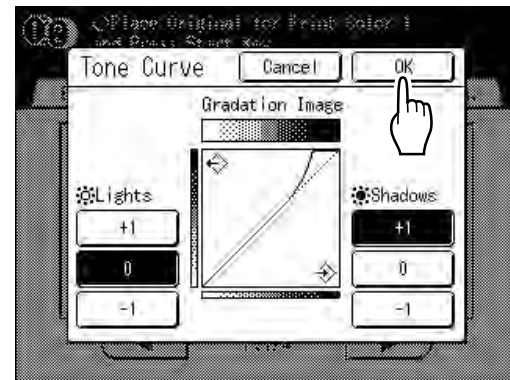

Returns to the Functions screen. Tone Curve setting is updated.



Selecting Scanning Contrast for the Original [Contrast]

Scanning contrast can be adjusted to accommodate background color or ink density of the original. Specify by selecting Auto or numeric levels (1-5). In the Auto mode, "Contrast" is automatically adjusted to the background color of the original for printing.

Important!:

- "Auto" is available only when Image Processing mode has been set to "Line".
 ↪ p.70

Note:

- Default Scanning Contrast can be set on the Admin. screen.
 ↪ p.174

1 Touch [Contrast] on the Master Making Basic Screen.

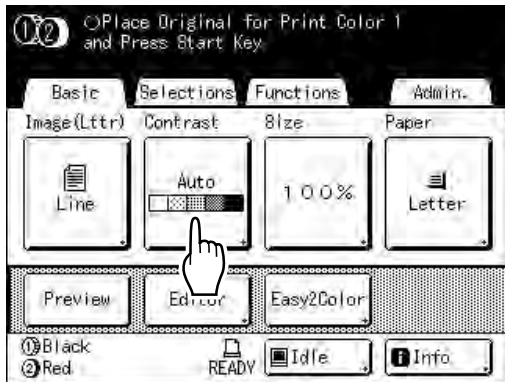

2 Touch the desired contrast or [Auto].

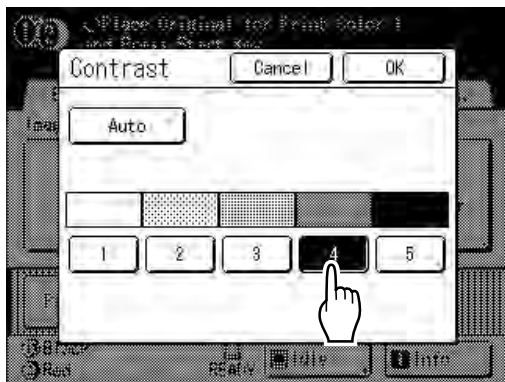

Levels of scanning contrast

- 1) : Very Light
- 2) : Light
- 3) : Standard
- 4) : Dark
- 5) : Very Dark

3 Touch [OK].

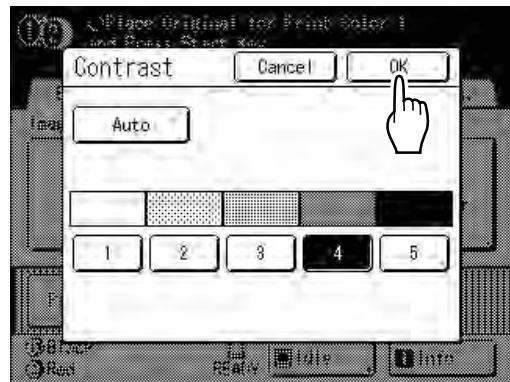

The following screen appears.



Returns to the Master Making Basic Screen. Contrast is updated.

Enlarging/Reducing Originals

[Standard Ratio] [Free] [Margin+] [Zoom]

The document can be printed enlarged or reduced. The following methods can be used to enlarge/reduce the original.

◆ Auto

Automatically adjusts zoom ratio to accommodate the paper size in the Paper Feed Tray.

◆ Standard Ratio

Enlarging or reducing a standard-sized original (Letter, Legal, A4, B5 etc.) to print in another standard size.

◆ Margin+

Reducing the original slightly. This feature is useful when allowing binding margins, or when text or diagram extends beyond the printing area.

☞ p.17

Specify reduction rate of 90%-99% on the Admin. screen.

☞ p.176

◆ Free

The top/bottom and left/right of the original can be magnified or reduced and printed as desired. Specify the zoom ratio between 50% and 200% in increments of 1%.

◆ Zoom

Allows you to specify numerical resize ratio.

Specify the zoom ratio between 50% and 200% in increments of 1%.

Note:

- Blank margins on edges are necessary in order to avoid paper jam and ink smudges on the back side. The machine will not print without margins. The top edge in particular needs $\frac{3}{16}$ " (5 mm) of margin space.
☞ p.17
 $\frac{3}{16}$ " (5 mm) wide area on the top edge (marked ▲) of the Stage Glass (or the ADF unit) cannot be scanned, regardless of enlargement or reduction settings.

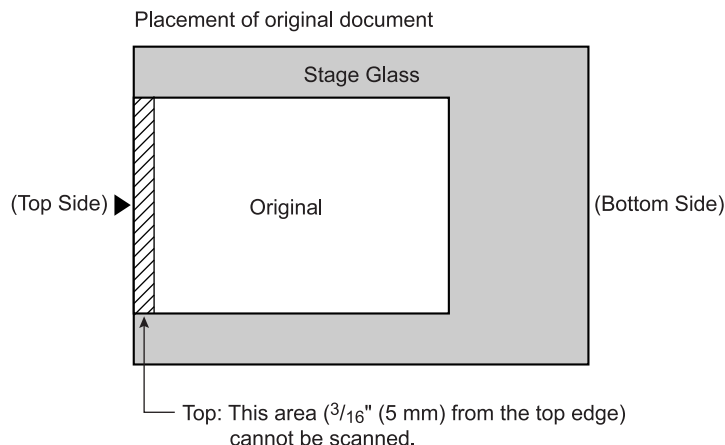

- Do not position the original within $\frac{3}{16}$ " (5 mm) of the top edge, or the top edge of its printed image will be cut off. This $\frac{3}{16}$ " (5mm) margin will remain even in the "Max. Scan" setting.
☞ p.101
- If the original document has no margin on its top edge, the top $\frac{3}{16}$ " (5mm) of its print will be cut off even when **[Margin+]** is selected. Move the original about $\frac{3}{16}$ " (5 mm) inwards from the top edge of the stage glass and reduce the size.

Enlargement and Reduction by Standard Ratio

[Standard Ratio] [Margin+]

1 Touch [Size] on the Master Making Basic Screen.

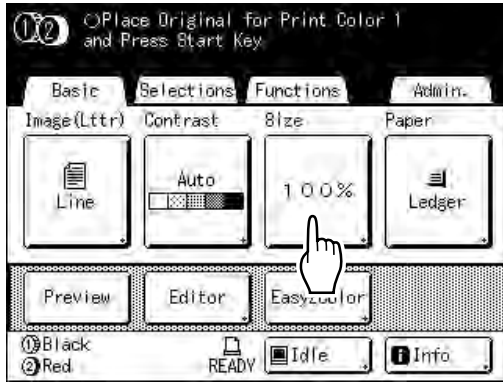

2 Touch the button corresponding to the desired size.

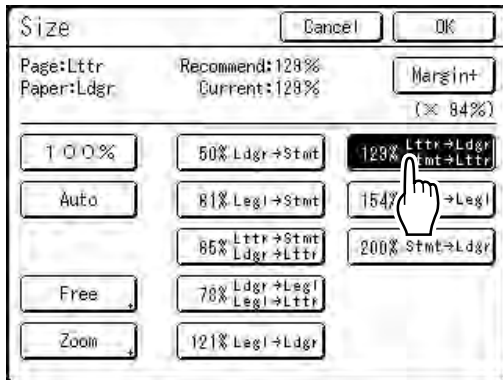

Touch [100%] to restore the original size.

Important!:

- The "Margin+" setting is not available when "Auto", "Zoom" or "Free" is selected.

Note:

- "Standard Ratio" and "Margin+" can be selected at the same time. The "Current" field will indicate the combined result of "Standard Ratio" × "Margin-Plus Rate" when both are selected.

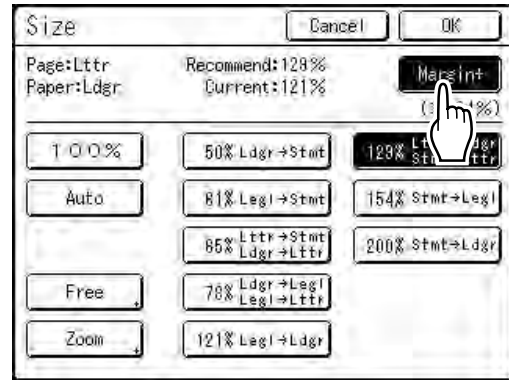

3 Touch [OK].

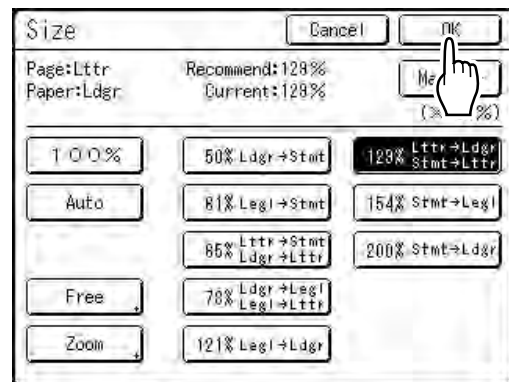

The following screen appears.



Returns to the Master Making Basic Screen. Size is updated.

Magnification/Reduction of a Changed Aspect Ratio [Free]

1 Touch [Size] on the Master Making Basic Screen.

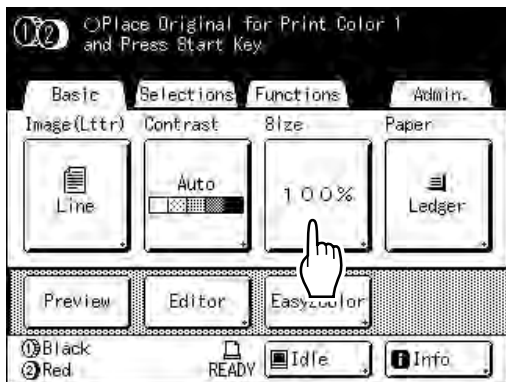

2 Touch [Free].

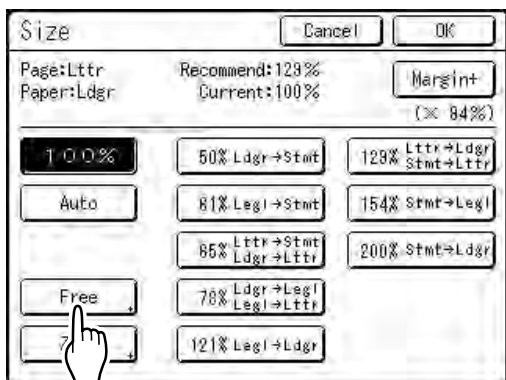

3 Touch ▲ or ▼ to adjust zoom ratio in horizontal or vertical directions.

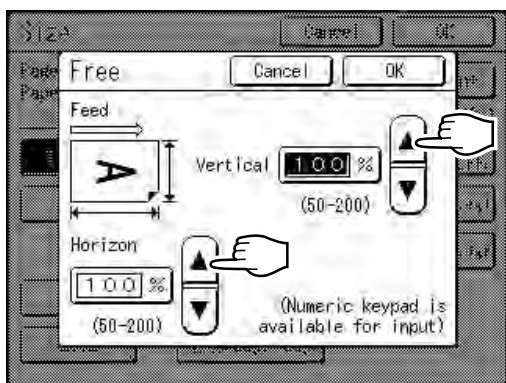

The reproduction size can be increased/ decreased in increments of 1%.

Note:

- Print Quantity Keys can also be used to enter numbers.
- Press the **C** key to restore the original size (100%).

4 Touch [OK].

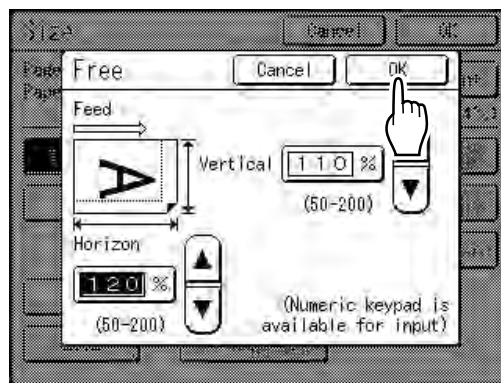

Returns to the Master Making Basic Screen. Size is updated.



Enlarging and Reducing with the Zoom Function [Zoom]

1 Touch [Size] on the Master Making Basic Screen.

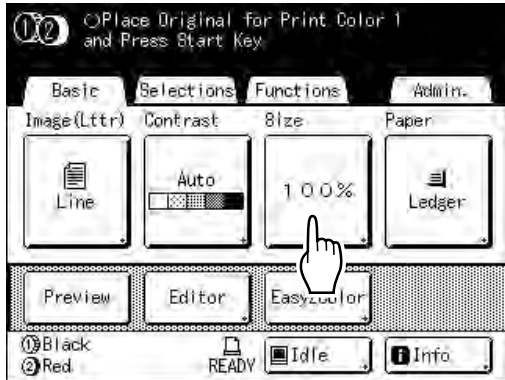

2 Touch [Zoom].

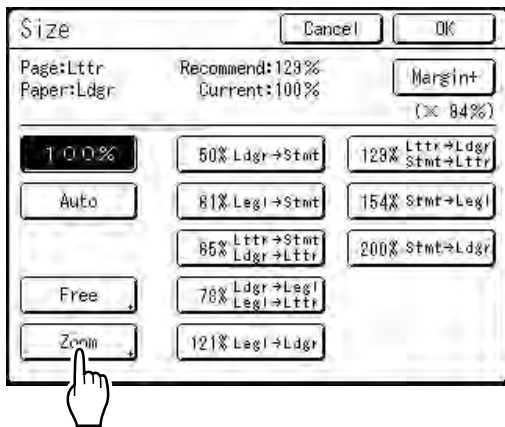

3 Touch ▲ or ▼ to change ratio.

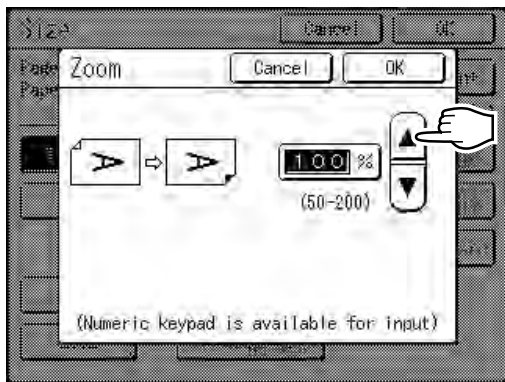

The reproduction size can be increased/decreased in increments of 1%.

Note:

- Print Quantity Keys can also be used to enter numbers.
- Press the **C** key to restore the original size (100%).

4 Touch [OK].

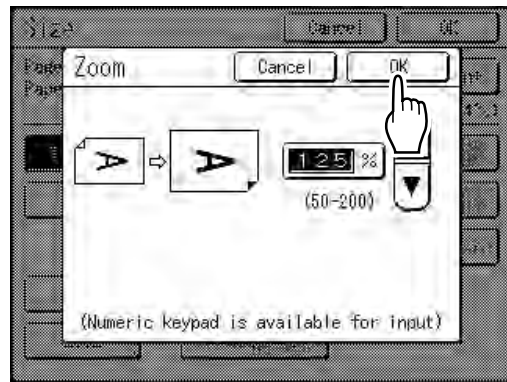

The following screen appears.



Returns to the Master Making Basic Screen. Size is updated.

Using Custom-Sized Paper [Paper]

The machine automatically detects standard-sized paper in the Paper Feed Tray to create a correct size master for printing. However, because non-standard paper sizes cannot be detected, they must be manually specified before a master can be made.

Important!:

- Custom paper size must be registered on the Admin. screen. Failure to do so may make an incomplete master.
☞ p.186

1 Touch [Paper] on the Master Making Basic Screen.

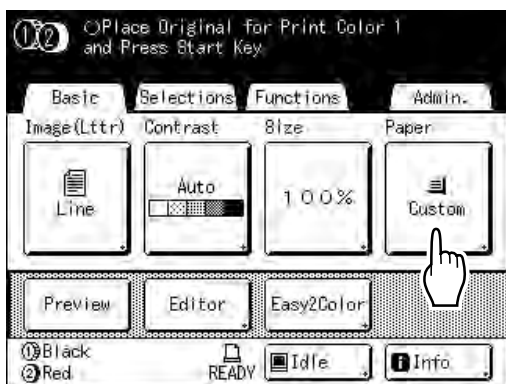

2 Touch the desired paper size.

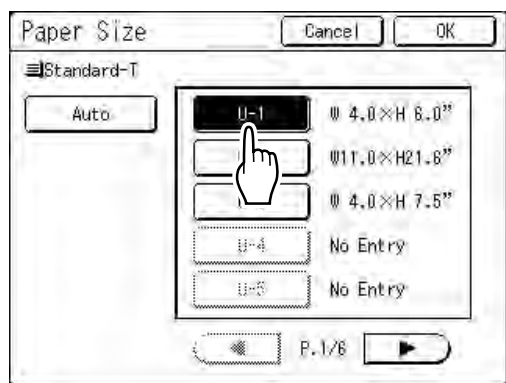

Note:

- Touch [Auto] to use standard-size paper.

Important!:

- Previously recorded custom paper sizes is displayed on this screen. Make sure to register any custom sizes not displayed here prior to use.
☞ p.186

3 Touch [OK].

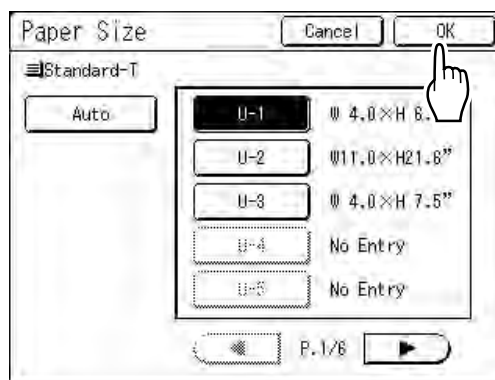

The following screen appears.



Returns to the Master Making Basic Screen. Paper size is updated.

Automatic Printing [Auto-Process]

Master-making and printing can be performed automatically in sequence.

When "Auto-Process" is selected, simply enter number of copies to print, then press the  key.

Important!:

- If you are using the ADF unit (option) for 2-Color printing, pay close attention to the order in which you place the original.
☞ p.41

Note:

- On the Admin. screen, you can make such a setting that "Auto-Process" is always set to ON when you reset or start the machine.
☞ p.174
- "ADF Semi-Auto" is another handy function when using the ADF unit (option).

1 Press the key.

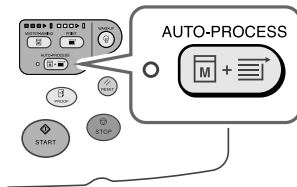

The Auto-Process Indicator turns on, and "Select Print Quantity" is displayed on the Master Making Basic Screen.

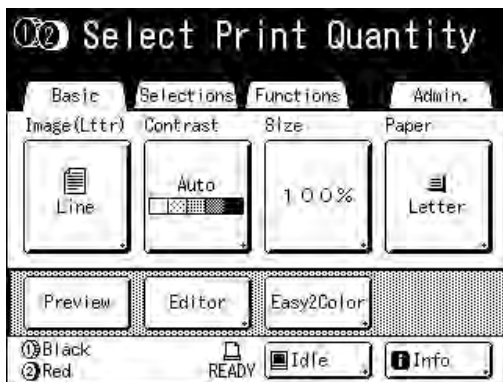

Input the number of copies prior to creating the master, because when "Auto-Process" is set, the job will be printed as soon as the master is created on Cylinder (Drum) 1 or Cylinder (Drum) 2.

2 Enter the number of copies using the Print Quantity Keys.

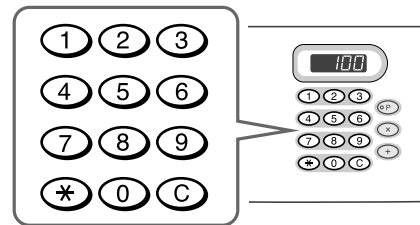

Note:

- To change the number, press the  key, then re-enter the correct number.

3 Press the key.

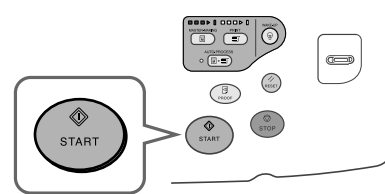

Creation of the master starts.

Once the masters are made on Cylinder (Drum) 1 and Cylinder (Drum) 2, printing automatically starts, and the number of copies indicated prints.

Note:

- To cancel "Auto-Process", press the  key again. The indicator turns off.
- When printing is completed, Print Quantity will restore the number originally entered.
- If multiple originals are placed on the ADF unit (option), "Auto-Process" is automatically set to "ON" by default, and all the originals are printed using "Auto-Process". This setting can be changed in "Admin.".
☞ p.174

Printing from Bound Documents

[Book Shadow]

This function erases the shadows appearing in the binding “spine” in the center as well as in the peripheral area when printing from magazines and books.

The printer automatically determines the area to delete.

Important!:

- If “Book Shadow” is selected during color printing, the settings are applied to both Cylinder (Drum) 1 and Cylinder (Drum) 2 (the setting cannot be applied to just Cylinder (Drum) 1 or just Cylinder (Drum) 2).
- The original must be placed as shown below. Align center on the top edge. The shadows will be erased.

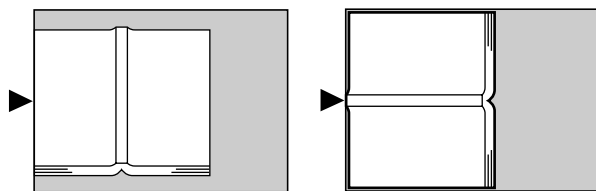

- “Book Shadow” is not available for bound books or magazines with images placed on the edge of the page or on the binding as shown below.
 - A continuous black image area (non-white) from the edge of the original

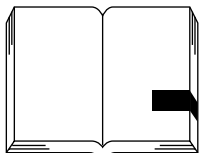

- A continuous black image area from the center of the original

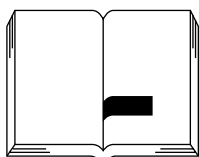

- “Ink Saving”, “Contrast” and “Easy 2Color” functions are not available when “Book Shadow” is selected.

Note:

- If the Gauge Cover is installed, remove the Gauge Cover before using the “Book Shadow” to delete the appropriate area.

1 Touch [Functions] on the Master Making Basic Screen.

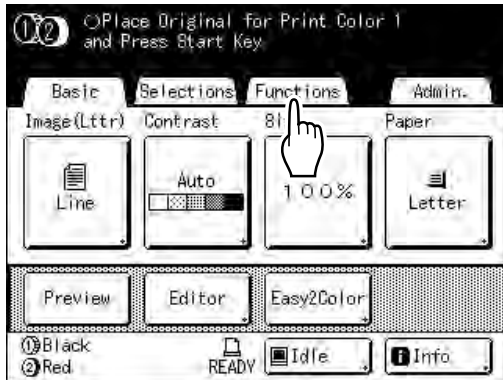

2 Touch [Book Shadow].

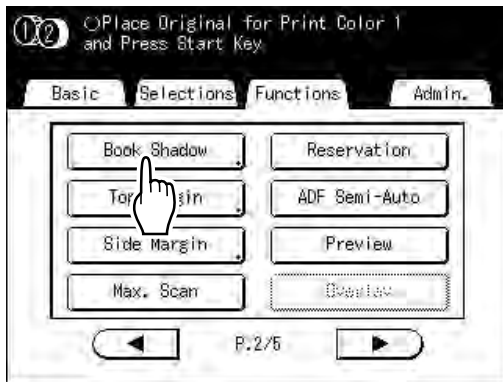

3 Touch the shadow processing method.

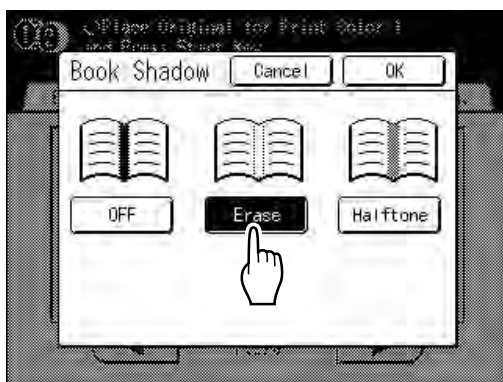

- **[Erase]:** Erases shadows near the center and around the original.
- **[Halftone]:** Photo processes the center shadow for a natural feel and deletes shadows that it can around the original.

4 Touch [OK].

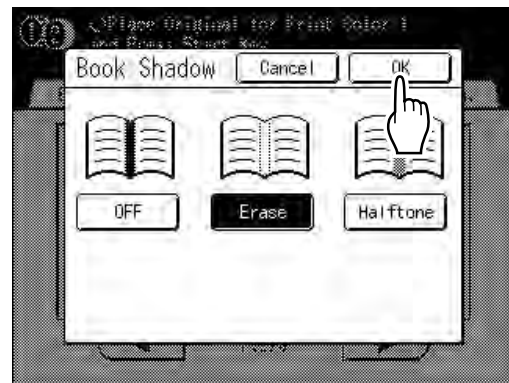

The following screen appears.

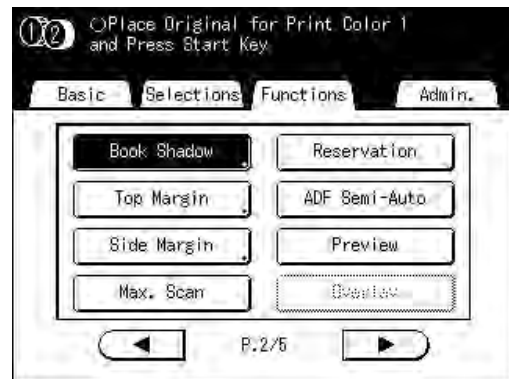

Returns to the Functions screen. Book Shadow setting is updated.

Note:

- If you are scanning a thick book such as an encyclopedia, raise the hinge of the stage glass cover and press down for best results.

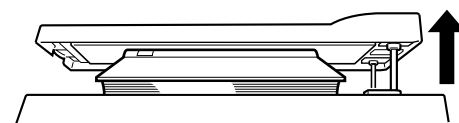

Saving Ink [Ink Saving]

Selecting “Ink Saving” makes a master that requires less ink when printing.

Important!:

- The ink conservation process may result in lighter prints than usual.
- “Contrast” and “Print Density Adjustment” functions are not available when **[Ink Saving]** is selected.
- This function is not available when printing the data from a computer.

1 Touch [Functions] on the Master Making Basic Screen.



2 Touch [Ink Saving].



“Ink Saving” is set.

“ Ink Saving” will appear in the message area.

Printing Side-by-Side on One Sheet

[2 Up] [Multi-Up Print]

“Multi-Up” function prints multiple originals on one sheet.

◆ 2 Up

Prints two copies of the same original side-by-side on one sheet of paper.

◆ Multi-Up Print

One or multiple originals (up to 4) can be printed on a single sheet of paper.

“Multi-Up Print” has the following three types:

- Single-Original: A single original is printed multiple times.
- Multiple-Original: Multiple originals are printed multiple times.
- Multi-Up Tickets: You can print multiple long, thin custom originals such as tickets.

Single-Original and Multiple-Original can print in quantities of 2, 4, 8 and 16 respectively.

Important!:

- Use standard-sized paper when using the “Multi-Up” function. With custom size paper placed, you cannot perform “Multi-Up” printing even when the size is stored on the Admin. screen.
- If you change “Image” between originals in Multiple-Original, you cannot use “Ink Saving”.

Note:

- These functions cannot be used with the following functions.
 - Link-Free Volume
 - Top Margin
 - Book Shadow
 - Side Margin
 - Size (Auto)
 - Format (Auto) (in Scan Mode)

Original Orientation and Print Results

The orientation of the original differs depending upon the number of images.
The orientation and print results for each possibility is shown below.

Important!:

- Leave a margin of at least $\frac{3}{16}$ " (5 mm) on the top edge of the Stage Glass. Allowing a proper margin is critical in well-balanced Multi-Up positioning.
☞ p.14

2 Up

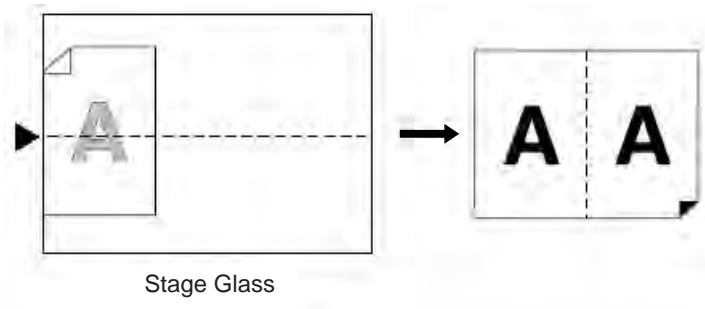

Prints two copies of the same original side-by-side on one sheet of paper.

Multi-Up Print

For Single-Original and Multiple-Original:

◆ 2 Up (2 on 1)

Prints two images of the original on one sheet of paper.

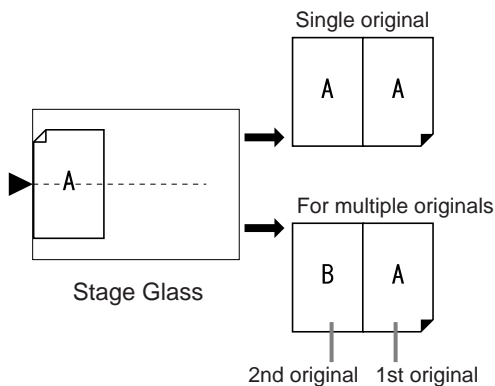

◆ **4 Up (4 on 1)**

Prints four images of the original on one sheet of paper.

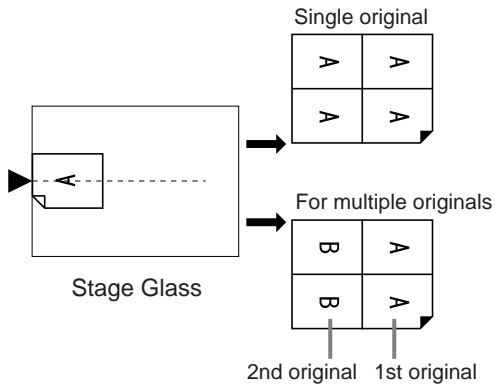

◆ **8 Up (8 on 1)**

Prints eight images of the original on one sheet of paper.

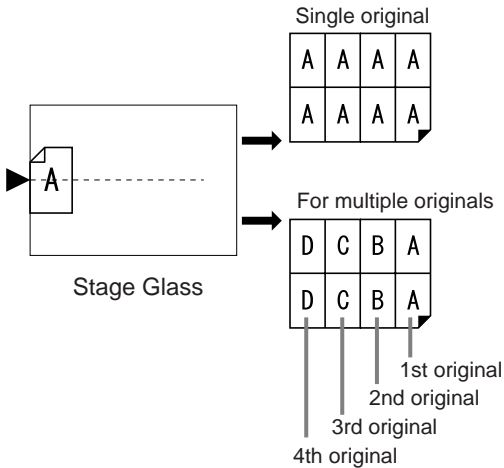

◆ **16 Up (16 on 1)**

Prints 16 images of the original on one sheet of paper.

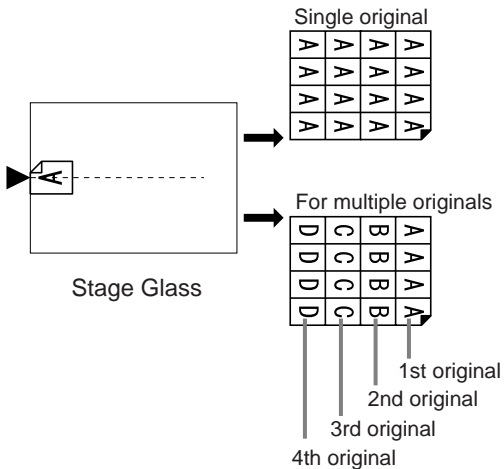

◆ **For** Multi-Up Tickets:

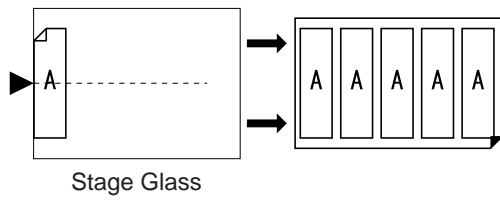

“Multi-Up Tickets” cannot be used with multiple originals.
The number of images printed is determined by the width of the ticket.

Orientation of Print Paper

Always place paper in the Paper Feed Tray as shown below.

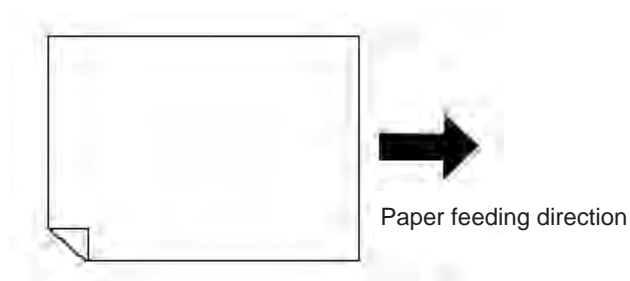

Enlargement/Reduction Ratio

For “Multi-Up Print”, the magnification/reduction ratio of the original differs depending upon the original size and the multi-up type, as well as the size of the print paper. The side-dependent change ratios are shown below.

◆ 2 Up

		Original	
		Letter	Statement
Printing Paper	Ledger	100%	127%
	Legal	77%	100%
	Letter	66%	100%
	Statement	50%	66%

		Original							
		A4	B5	A5	B6	A6	B7	A7	B8
Printing Paper	A3	100%	116%	141%	163%	200%	---	---	---
	B4	87%	100%	123%	142%	173%	200%	---	---
	A4	71%	82%	100%	116%	138%	163%	200%	---
	B5	61%	71%	87%	100%	122%	141%	173%	200%

◆ 4 Up

		Original			
		Ledger	Legal	Letter	Statement
Printing Paper	Ledger	50%	60%	66%	100%
	Legal	---	50%	50%	77%
	Letter	---	---	50%	66%
	Statement	---	---	---	50%

		Original									
		A3	B4	A4	B5	A5	B6	A6	B7	A7	B8
Printing Paper	A3	50%	58%	71%	82%	100%	116%	141%	163%	200%	---
	B4	---	50%	61%	70%	87%	100%	122%	141%	173%	200%
	A4	---	---	50%	58%	71%	82%	100%	115%	142%	164%
	B5	---	---	---	50%	61%	71%	87%	100%	123%	142%

◆ 8 Up

		Original	
		Letter	Statement
Printing Paper	Ledger	50%	66%
	Legal	---	50%
	Letter	---	50%

		Original							
		A4	B5	A5	B6	A6	B7	A7	B8
Printing Paper	A3	50%	58%	71%	82%	100%	116%	141%	163%
	B4	---	50%	61%	71%	87%	100%	123%	142%
	A4	---	---	50%	58%	71%	81%	100%	116%
	B5	---	---	---	50%	61%	70%	87%	100%

◆ 16 Up

		Original
		Statement
Printing Paper	Ledger	50%

		Original					
		A5	B6	A6	B7	A7	B8
Printing Paper	A3	50%	58%	71%	81%	100%	116%
	B4	---	50%	61%	70%	87%	100%
	A4	---	---	50%	57%	70%	81%
	B5	---	---	---	50%	60%	70%

Note:

- See [p.96](#) for information about Multi-Up Tickets.

2 Up Operation

1 Select a color mode.

Select 1-Color or 2-Color print.

Note:

- See p.25 for how to select a color mode.

2 Place an original and load paper.

- When 2-Color printing with 2 originals p.40
- When printing with 1 color p.58

Important!:

- Pay attention to the orientation of the original. For "2 Up", make sure to place the original as the diagram demonstrates. The same is true when using the ADF unit.

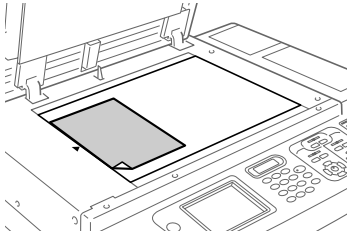

3 Touch [Functions] on the Master Making Basic Screen.

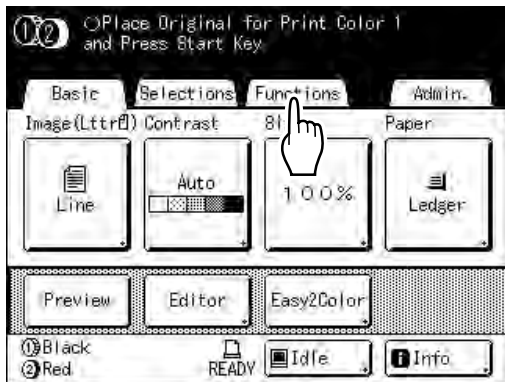

4 Touch [2 Up].

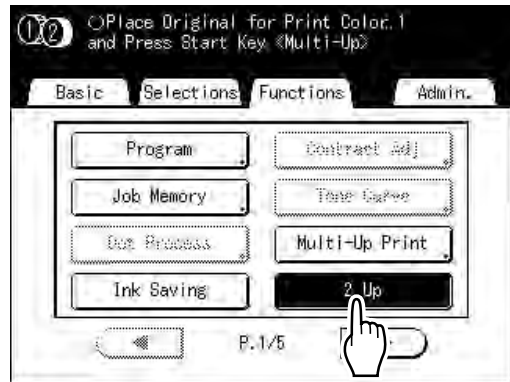

5 Make necessary settings.

Make various settings as needed. After this, please follow the same operations for normally making a master and 1-Color and 2-Color printing.

6 Press the key.

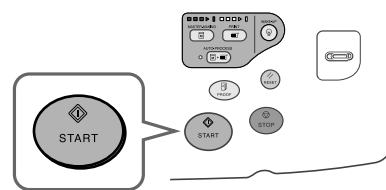

Starts scanning of the original.

Operation for Multi-Up Printing

1 Select a color mode.

Select 1-Color or 2-Color print.

Note:

- See p.25 for how to select a color mode.

2 Place an original and load paper.

- When 2-Color printing with 2 originals p.40
- When printing with 1 color p.58

Note:

- Pay attention to the orientation of the original. p.88

3 Touch [Functions] on the Master Making Basic Screen.



4 Touch [Multi-Up Print].



5 Select the Page Size to use.

Touch the Page Size same as the original and touch **[Next]**.

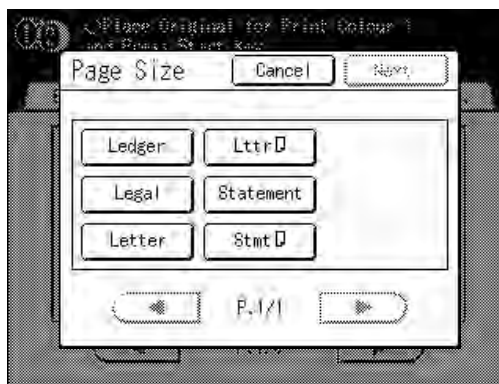

Reproduction Size is set automatically and Multi-Up Print screen is displayed.

6 Touch [Single] for Single-Original, touch [Multiple] for Multiple-Original.

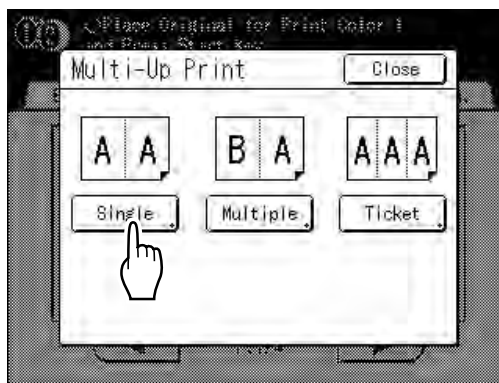

Except for the original placement method, operations for “Single-Original” and “Multiple-Original” are basically the same. This example is for “Single-Original”.

7 Touch the button of the number of images to use.

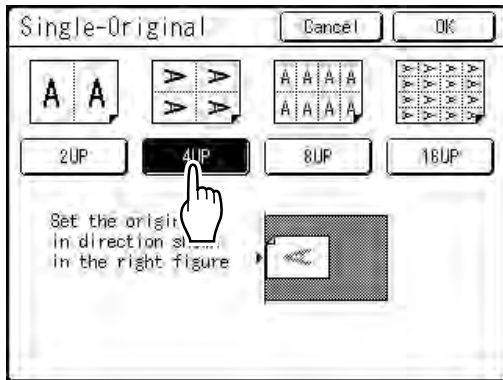

To cancel the “Multi-Up Print” settings, return to the previous screen and touch **[Cancel]**.

8 Touch [OK].

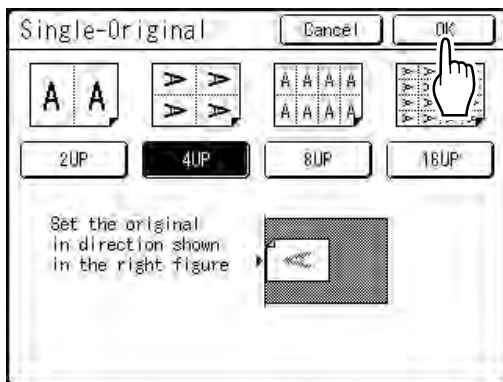

The following screen appears.



Returns to the Functions screen. Multi-Up Print setting is updated.
An error will occur in the following instances.

Following the instructions on the screen.

- An original is not set
- Paper is not set
- The correct size paper is not set

9 Make necessary settings.

Make various settings as needed.

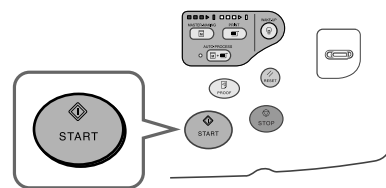

10 Press the  key.



Starts scanning of the original.

After this, please follow the same operations for normally making a master for 1-Color and 2-Color mode.

Important!:

- After displaying the message, “Place Another Original and Press Start Key To Cancel, Press Stop Key” the machine waits for the next original to be loaded. Set the next original and press . Press  to cancel the “Multi-Up Print” mode.

Note:

- When using “Multiple-Original” mode, in the case that the actual number of pages in the document is less than the number of pages specified in the mode settings, set an equivalent number of blank pages in the machine to make up the specified number.

☞ p.88 “Original Orientation and Print Results”

Operation for Multi-Up Tickets

For “Multi-Up Tickets”, the specification of the short edge size of the original (the width) is used to calculate the number of images that can be printed on one sheet of paper (print paper size divided by short edge size of the original). A ticket width of between 50 mm and 210 mm can be specified.

Ex.)

Short edge of the original $1\frac{15}{16}$ " (50 mm)

Long edge of the print paper $11\frac{11}{16}$ " (297 mm) (A4 size)

$11\frac{11}{16} \div 1\frac{15}{16} = 5$ ($297 \div 50 = 5$) with a remainder of approx. $1\frac{27}{32}$ (47 mm)

In this example, 5 images print on one sheet of paper.

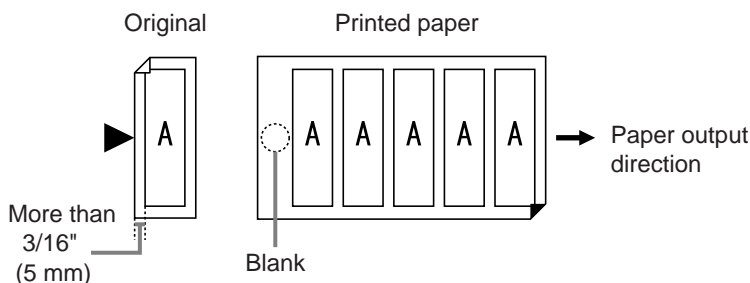

1 Select a color mode.

Select 1-Color or 2-Color print.

Note:

- See -p.25 for how to select a color mode.

2 Place an original and load paper.

Place the original on the Stage Glass.

For 2-Color printing, place the original for Cylinder (Drum) 1.

Important!:

- Pay attention to the orientation of the original.

3 Touch [Functions] on the Master Making Basic Screen.

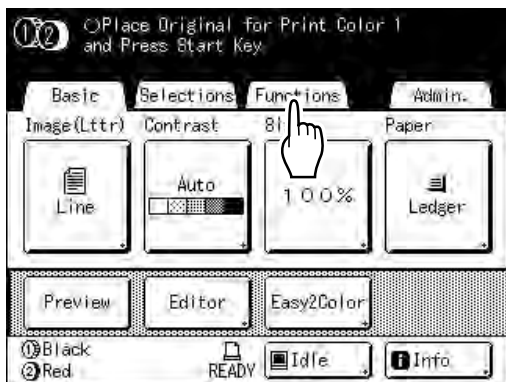

4 Touch [Multi-Up Print].



5 Select the Page Size to use.

Touch the Page Size same as the original and touch [Next].

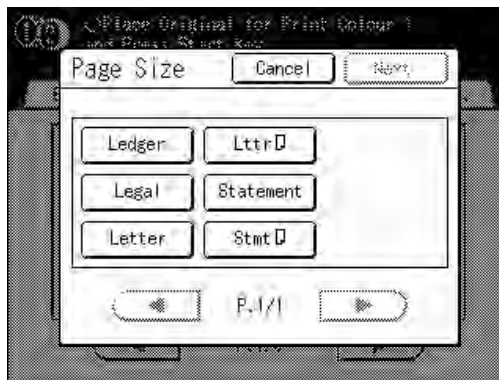

Reproduction Size is set automatically and Multi-Up Print screen is displayed.

6 Touch [Ticket].

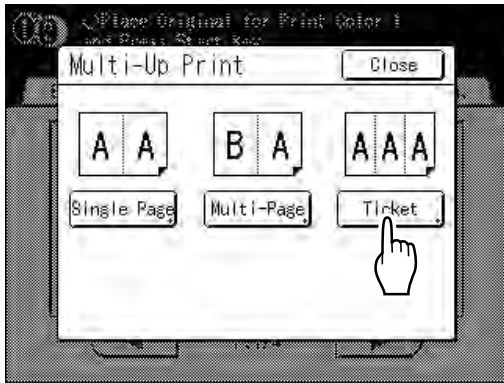

7 Touch ▲ or ▼ to specify the short edge size of the original (the width).

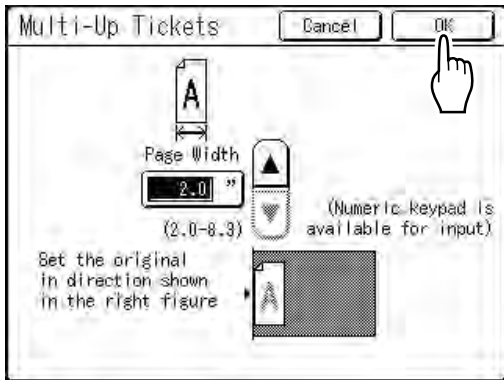

Important!:

- If you have enlarged/reduced size in step 9 (setting print functions), be careful about the following points.
- Specify the ticket width after enlarging/reducing.
- If you magnified the size, make sure that the bigger size does not exceed the specified "Page Width" or the short edges of the print paper.
- When magnifying, make sure to prepare paper that fits the enlarged size.

8 Touch [OK].

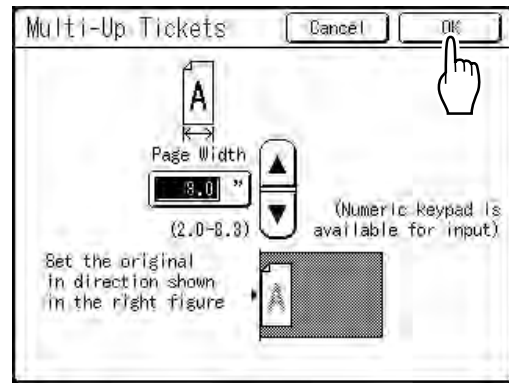

The following screen appears.



Returns to the Functions screen. Multi-Up Tickets setting is updated.

An error will occur in the following instances. Following the instructions on the screen.

- An original is not set
- Paper is not set
- The correct size paper is not set

9 Make necessary settings.

Make various settings as needed.

10 Press the key.

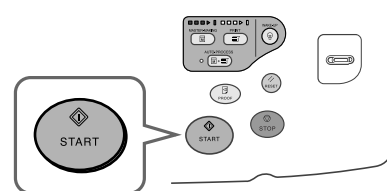

Starts scanning of the original.

For 2-Color printing, place the original for Cylinder (Drum) 2.

After this, please follow the same operations for normally making a master for 1-Color and 2-Color mode.

Switching Masters of Just One Cylinder (Drum) [OneSide MasterMake]

[OneSide MasterMake]

When 2-Color printing, you can switch just one of the two originals and print.

This is a handy function when printing different letters using the same letterhead. Simply create another master for the text, retaining the original master for the letterhead.

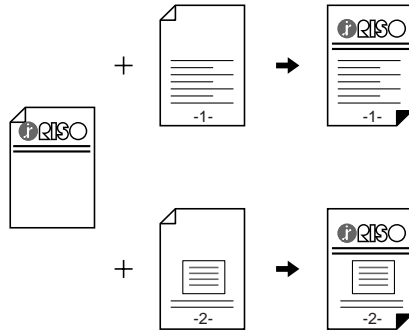

1 The first of the 2-Color print is executed.

“2-Color Printing with 2 Originals” (p.40)

Note:

- If you are connecting the printer with a computer, we recommend that you set “Reservation”. The master in use will be discarded if data is received from the computer during a print job. You can prevent this type of interruption from occurring. p.159

2 Once the initial printing is completed, touch [Functions] on the Print Basic Screen.

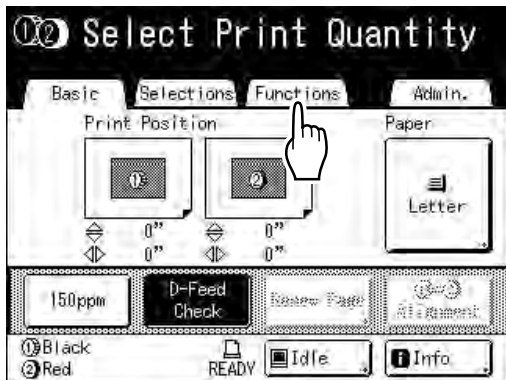

3 Touch [OneSide MasterMake].

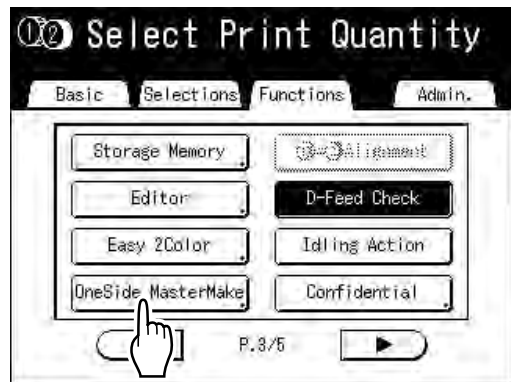

4 Touch the button of the cylinder (drum) for which you are changing the original.

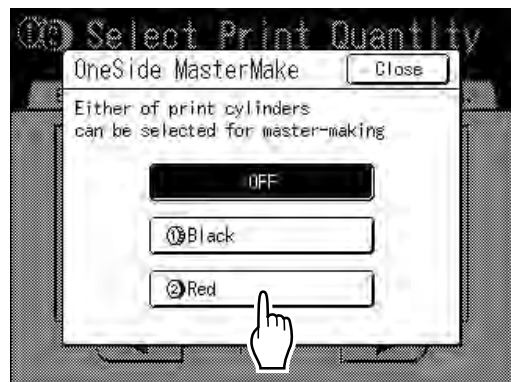

The following screen appears.



Returns to the Functions screen. OneSide MasterMake setting is updated.

5 Place the changed original.

Place on Stage Glass or in ADF unit (option). See "2-Color Printing with 2 Originals" (p.40).

6 Make necessary settings.

You can configure functions to apply to the new original as needed. If you make no settings, the same settings as the first print are used.

7 Press the key.

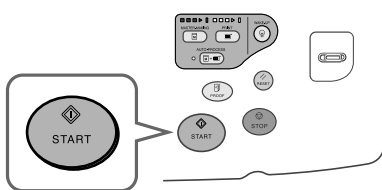

A master is made on the cylinder (drum) specified in step 4.

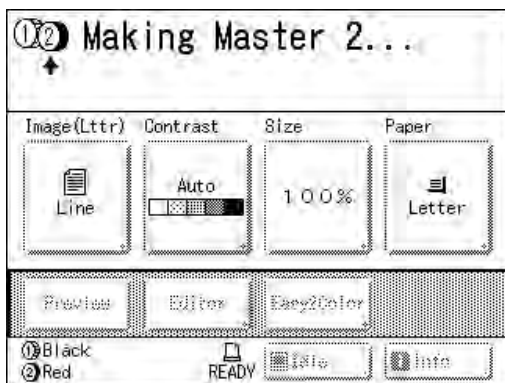

Once the master is made, a proof copy using only Cylinder (Drum) 2 is printed, and then a 2-Color proof copy is printed.

When a proof copy is printed, the Print Basic Screen appears.

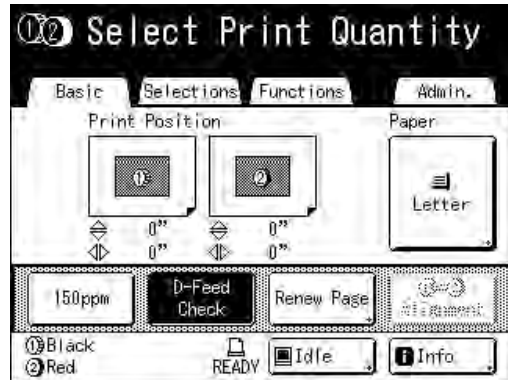

8 Check the proof copy result.

Check the proof copy; e.g., print position and density.

If necessary, change print position and density.

- Print Position (p.115)
- Print Density (p.114)
- Interval Printing (p.120)
- Jump Wing Control (p.122)

After adjustment, press the  key to print a proof copy.

Note:

- You can also adjust the print position, the density, and the speed while print process is in progress.

9 Enter the number of copies using the Print Quantity Keys.

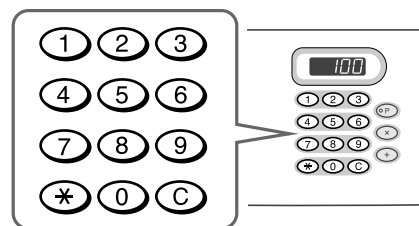

The specified number is displayed on the Print Quantity Display.

Note:

- To change the number, press the  key, then re-enter the correct number.

10 Press the  key.

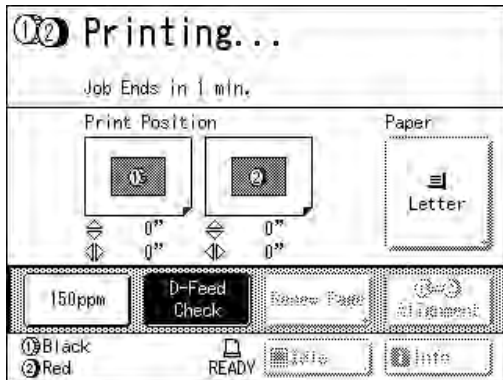
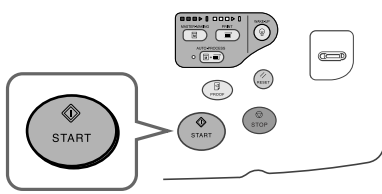

The specified number of copies will be printed.

Note:

- Press the  key to interrupt printing operation currently underway.

Making a Master that Utilizes the Maximum Printing Area [Max. Scan]

When a master is made, automatic paper size detection and image size adjustment applies to allow appropriate print margins. This is to prevent paper jams, and to keep internal roller free of ink stains.

By selecting “Max. Scan”, maximum printing area will apply to the scanned image, regardless of the print paper size or original document size.

◆ Maximum Printing Area

MZ990/MZ790: 11⁷/₁₆" × 16³/₄" (291 mm × 425mm)

MZ770: 11⁷/₁₆" × 16¹/₄" (291 mm × 413mm)

Important!:

- Be sure to check the sizes of the original document and the printing paper first.
☞ p.14
- The ³/₁₆" (5 mm) margin on the top cannot be scanned even in the “Max. Scan” setting.
- Do not use print paper smaller than the area of the image made on the master.
- The entire surface of the Stage Glass must be clean.
By scanning the maximum size, dirt found outside the original document area will also be included in the master.
This may cause the internal roller to be stained with ink.

1 Touch [Functions] on the Master Making Basic Screen.

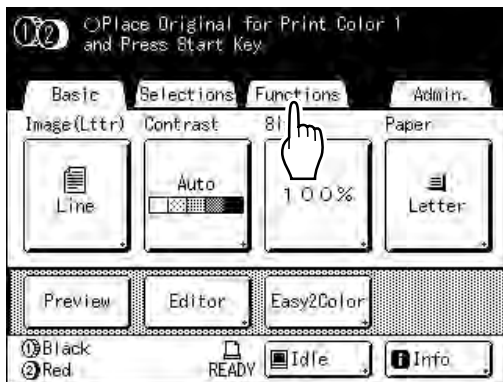

2 Touch [Max. Scan].

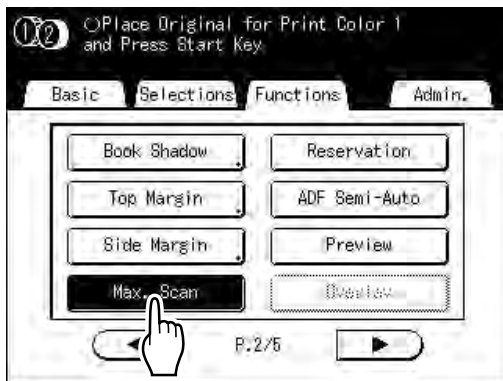

“Max. Scan” is selected.

Reproducing the Master [Renew Page]

The data from the last master-making process is temporarily stored on the machine.

Using this data, another master can be reproduced without repeating steps to scan the same original.

“Auto Page Renewal” is a function that automatically recreates a master when a specified number of pages are printed. If you are printing a high-volume job of thousands or tens of thousands of copies, the master may degrade before the job is completed.

If you set “Auto Page Renewal” to “ON” prior to starting a large-volume print job, a master will be automatically recreated when the specified number of copies is reached (Auto Renewal Point). This allows you to maintain a consistent print quality from start to finish.

Note:

- When 2-Color printing, you can select the cylinder (drum) on which to recreate the master. When 1-Color printing, the current cylinder (drum) is used to recreate the master.
- When 2-Color printing, you can change Cylinder (Drum) 1 and the master on Cylinder (Drum) 2 and recreate the master (change print color).
- “Renew Page” works with data sent from a computer as well. However, if multiple pages exist, only the last page will be processed with “Renew Page”.
- When direct printing, you can “Rotate” the original and recreate a master.
- “Renew Page” function is not available:
 - immediately after startup
 - after pressing the  key
 - after executing “Auto Clear” (“Changing Default settings” p.173)
 - after performing “Confidential”
 - after master-making for Data Output Mode (when the optional Key Card Counter is installed.)
 - when an error has occurred during master-making
 - after performing “Link Print”
- When “Renew Page” or “Auto Page Renewal” is selected, 2 proof copies will be made. When the print position has been adjusted, the printer will center the cylinders (drums) to their original position, recreate the master and print a proof copy. Then, the cylinders (drums) will move to the previously adjusted position and print another proof copy.

Recreating a Master

1 Touch [Functions] on the Print Basic Screen.

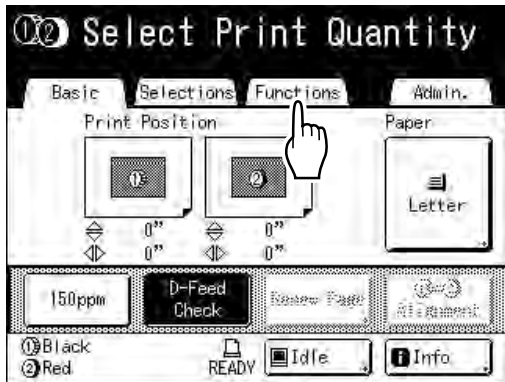

2 Touch [Renew Page].

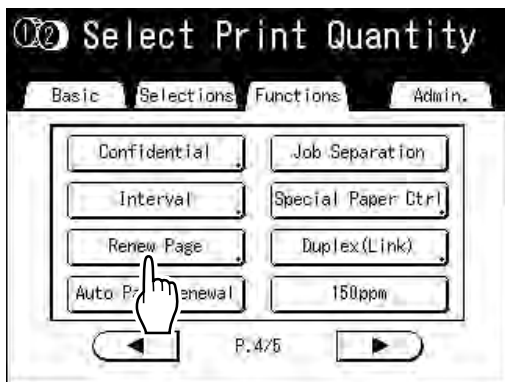

The display screen for 2-Color and 1-Color printing are different.

◆ For 2-Color Printing

The Cylinder (Drum) selection screen appears. Touch the button of the cylinder (drum) used to recreate the master.

Note:

- If you touch and select **[Sw.Color]**, you can change the masters on Cylinder (Drum) 1 and Cylinder (Drum) 2 (a handy function if you've inadvertently misplaced the original order).
- If you touch and select **[Rotate]**, you can rotate the original 180 degrees for renewing the master.
- When **[Rotate]** is set, the machine rotates 180 degrees for renewing the master while executing **[Auto Page Renewal]**.

- To cancel **[Rotate]**, touch **[Rotate]** again.

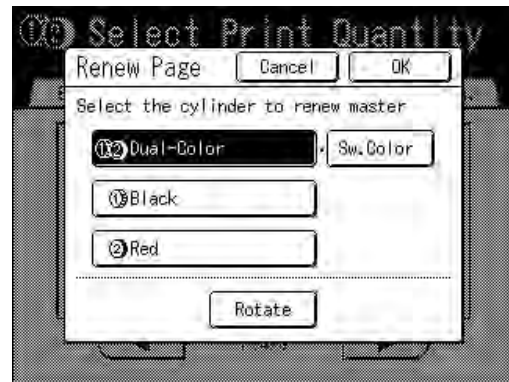

◆ For 1-Color Printing

The following screen appears.

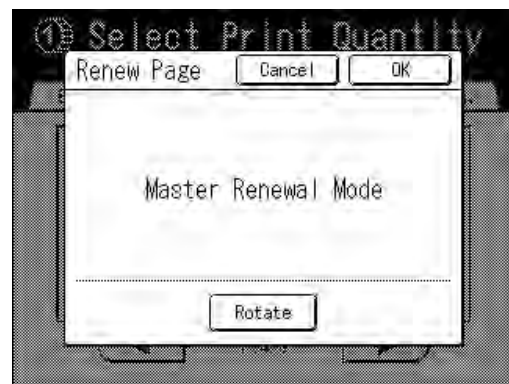

3 Touch [OK].

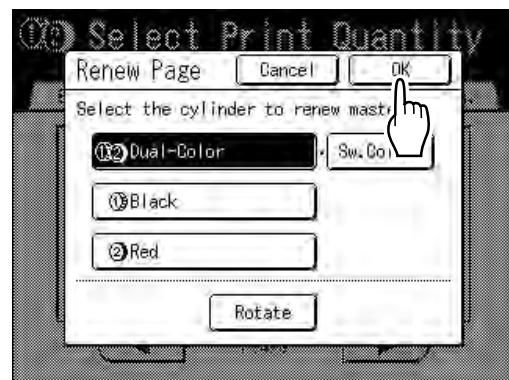

"Renew Page" begins reproducing the master.

Using Auto Page Renewal

In order to use “Auto Page Renewal”, you must enable it in “Admin.” prior to use.

If “Auto Page Renewal” is activated and “Auto Page Renewal” is set to “ON”, “Auto Page Renewal” can be executed during a print job.

Important!:

- If “Auto Page Renewal” is not activated in “Admin.”, “Auto Page Renewal” cannot be set to “ON”.
☞ p.177
- The “Auto Page Renewal” is set to “OFF” in the following instances.
 - When printing with “Program”
 - When the  is pressed
 - When attempting to process the next job with direct print

Note:

- The factory settings are such that a master is recreated every 1000 copies, with a setting to print 3 proofs. This setting can be changed in “Admin.”.

Turning ON “Auto Page Renewal”

1 Touch [Functions] on the Print Basic Screen.

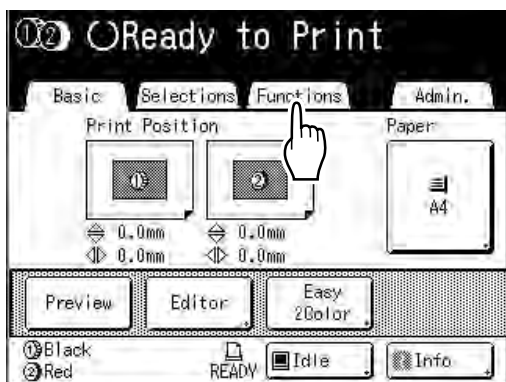

2 Touch [Auto Page Renewal].

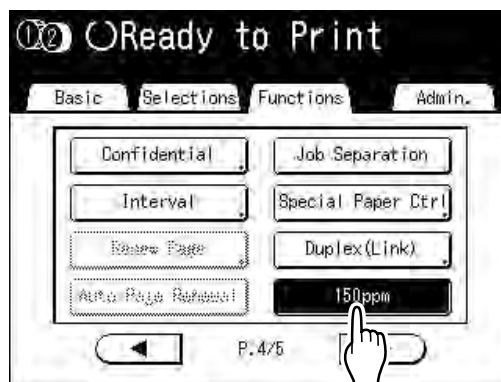

“Auto Page Renewal” is activated.
 When you print with these settings, “Auto Page Renewal” will be executed after the specified number of copies are printed.

Cutting the Top Margin of the Original and Printing [Top Margin]

You can cut the top portion of the margin to between 0 to 3.9" (99 mm) and make a master.

This feature enables you to skip the registration marks* on the original and print on the finish-sized paper without any of these marks.

*** About the Registration Mark**

In the field of commercial printing, it is normal to print on paper that is larger than the finished size and then cut down to the finished size afterwards. The symbol that indicates the position to cut in this event is known as the registration mark.

Important!:

- When you are setting the "Size", magnify/reduce using the area that skips the set value. Do not use "Auto".

Note:

- This function cannot be used with "2 Up".

Cylinder (Drum) 1 is used for the "Top Margin" when 2-Color printing. You can set Cylinder (Drum) 2 to be used for individual originals. Multiple settings are available depending upon the cylinder's (drum's) ink color and print aim. For example, you can set both originals or just one original.

1 Place an original and load paper.

Place the original face down on the Stage Glass. Align center on the top edge, and close Stage Cover.

Important!:

- An ADF unit (option) cannot be used with "Top Margin".

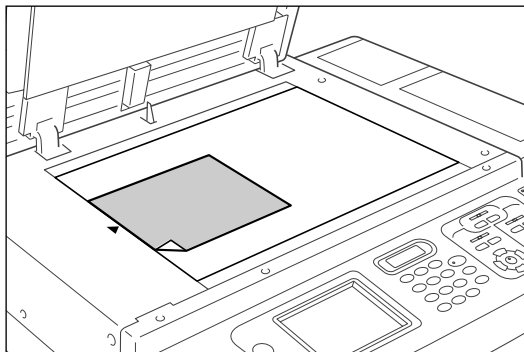

2 Touch [Functions] on the Master Making Basic Screen.



3 Touch [Top Margin].

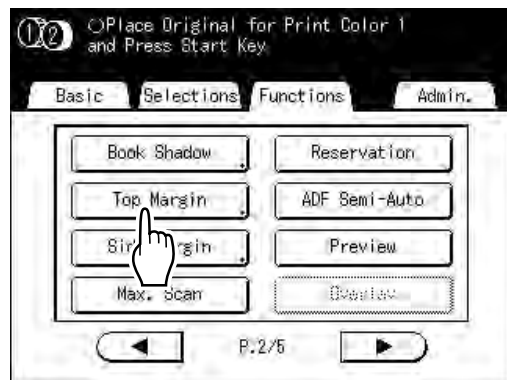

4 Touch [ON].

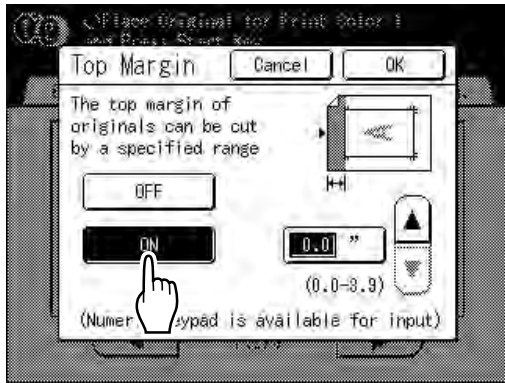

Returns to the Functions screen. Top Margin setting is updated.

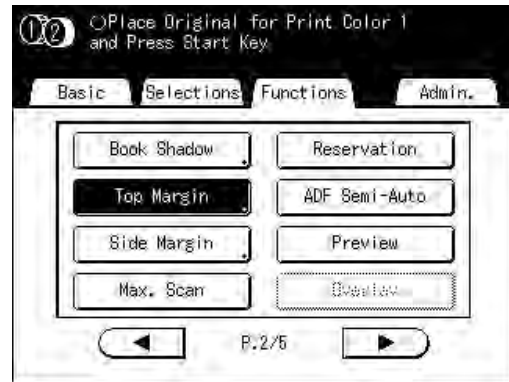

5 Touch or to specify the cut width.

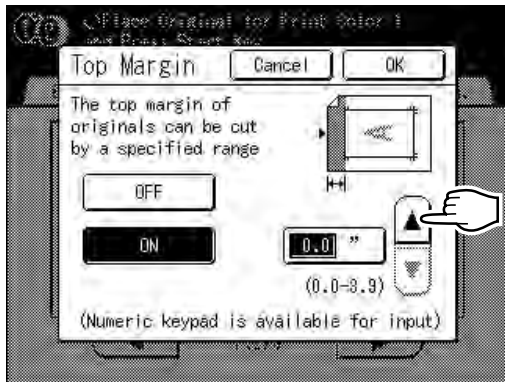

You can set from 0 to 3.9" (99 mm).

Note:

- Print Quantity Keys can also be used to enter a value.

6 Touch [OK].

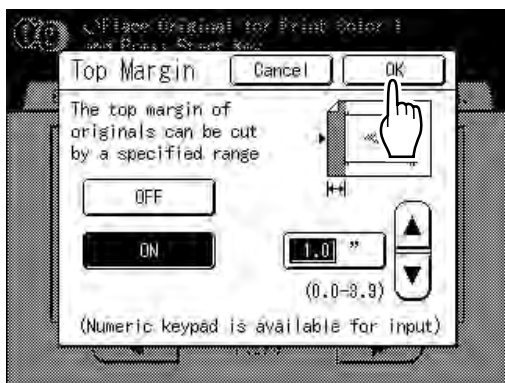

Adjusting the Side Margins of the Master

[Side Margin]

If you are using the ADF unit to print multiple originals and need to move the left and right margins to make a master, use "Side Margin" for one simple operation to offset the margins for all the originals (up to 0.4" (10 mm) left/right). You can also use "Side Margin" to create side margins when printing an original from the stage glass.

Important!:

- "Side Margin" is a function intended to adjust the location of the master.
If there are no white margins on the left or right of the original, a margin will not be created (the function is not intended to add and print a margin).

Note:

- This function cannot be used with the following functions.
 - Multi-Up Print
 - 2 Up
- If "Side Margin" and the print location controls on the control panels are used together, the final print location of the original can be adjusted up to 0.8" (20 mm).

1 Touch [Functions] on the Master Making Basic Screen.



2 Touch [Side Margin].

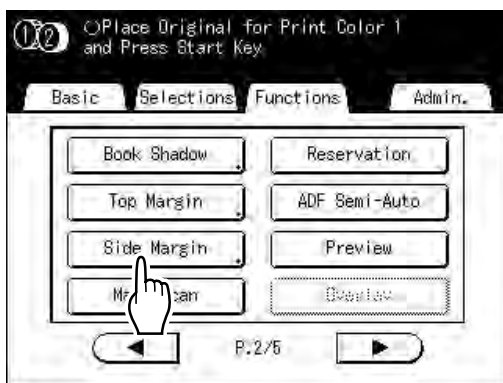

3 Touch [Left] or [Right] to adjust.

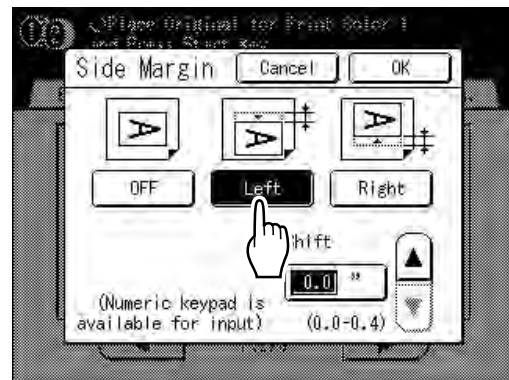

4 Touch [Up] or [Down] to specify the shift distance.

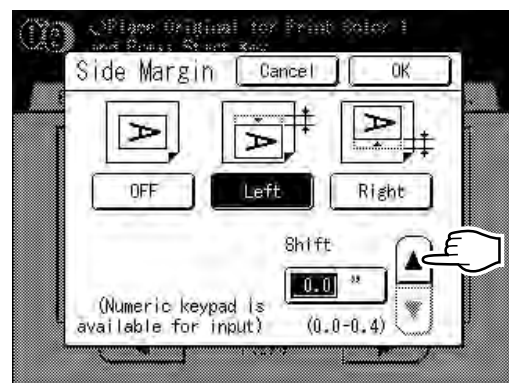

You can set from 0 to 0.4" (10 mm).

Note:

- Print Quantity Keys can also be used to enter a value.

5 Touch [OK].

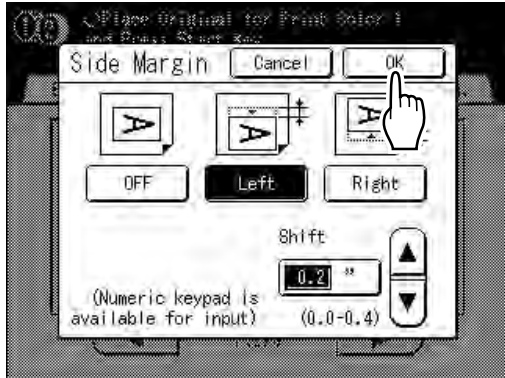

Returns to the Functions screen. Side Margin setting is updated.

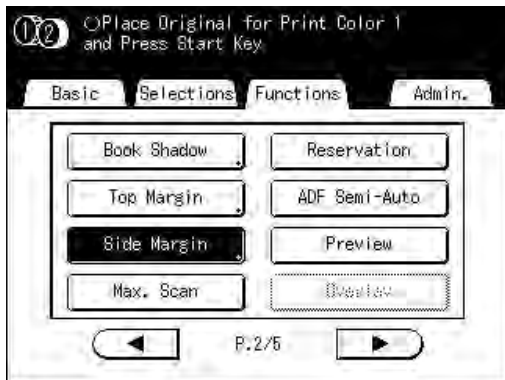

Important!:

- By using “Side Margin”, the opposite side of the side margin may be pushed out of the print area and not print. Check the margins of the original prior to setting

Checking the Print Image Prior to Making Master [Preview]

You can check what the actual master will look like by previewing an image of the scanned original or an image of data sent from a computer. This function is handy for making sure that the “Easy 2Color” separation was successful, and for checking the layout or final image of a Multi-Up job.

The operation and display timing differ depending upon the mode.

Mode name (original type)	When set	When to display	If “Auto Processing” is ON
Printing from the Original Document	When setting functions related to Master Making (settings from Functions)	After Scanning the Original	Scans the original, then temporarily stops to display preview.
Scan Mode	When setting functions (master making functions) related to Scanning (setting from Functions)	After Scanning the Original	When in scan mode, an original is scanned and then saved, so there is no “Auto Process” operation. However, if multiple originals are placed in an ADF unit, you can touch [Continue] after reviewing the preview to start the scan of the next original.
Printing Original Data from a Computer	Stopping the print job prior to making a master (Semi-Auto(Print)/Auto Process OFF), after the machine has received the original data	Displays when touched	A preview is not shown if data is sent from the printer driver with “Auto Print” “ON”.
Retrieving Stored Data and Printing	When retrieving stored data (set on the Storage Basic Screen)	Displays when touched	If you touch [Preview] , it displays immediately. Touch [Continue] to make a master/print with “Auto Process”.

Note:

- Preview shows an image oriented towards output after printing.
- It shows the scanned original as-is. A margin is required when actually printing. Check to make sure that the margins are sufficient.
- If you are 2-Color printing, a 2-Color preview will be displayed after the original has been scanned on Cylinder (Drum) 1 and Cylinder (Drum) 2.
- Even if a single original has been separated using the “Easy 2Color” function, each of the separated results is displayed.
- In “Direct Print” operation, **[Preview]** will be displayed on the Master Making Basic Screen when data is received from the computer.
☞ p.67
- When in Link mode (when a linked printer (sold separately) is connected), the original image after scanning and prior to output from the linked printer is previewed.

Actions Available on the Preview Screen

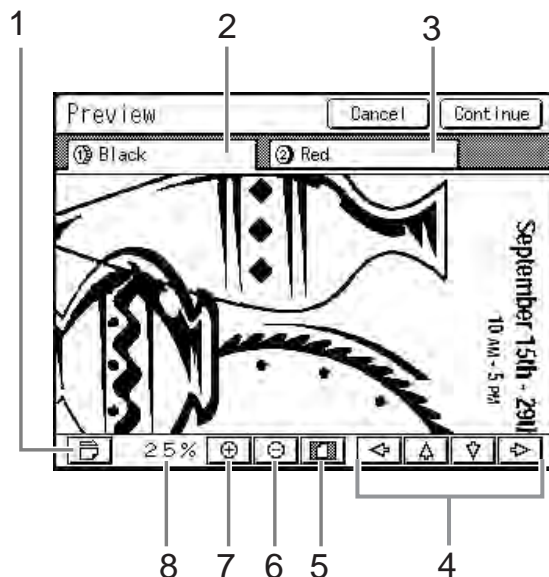

- | | |
|---|--|
| <p>1) Rotate Image Button
Allows you to rotate the displayed image 90 degrees.</p> <p>2) Cylinder (Drum) 1 Original</p> <p>3) Cylinder (Drum) 2 Original</p> <p>4) Scroll Button
The image moves in the direction of the displayed arrow.</p> | <p>5) Show All Button
Shows the entire image.</p> <p>6) Reduce Button
Shrinks the preview display each time it is touched.</p> <p>7) Magnify Button
Magnifies the preview display each time it is touched.</p> <p>8) Displays the size of the current display.</p> |
|---|--|

Setting and Printing the Preview Display

The operational procedures for “Printing Hardcopy” are explained below.

- 1 Place an original and load paper.**
- 2 Touch [Functions] on the Master Making Basic Screen.**
- 3 Touch [Preview].**

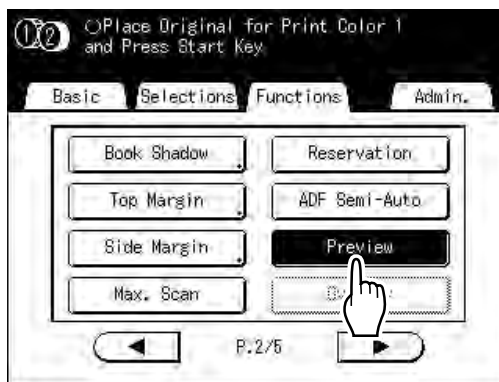

Preview setting is updated.

4 Make necessary settings.

You can configure print functions to apply to the new original as needed.

5 Press the key.

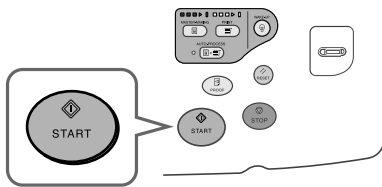

A scan of the original begins, and can be previewed on the Preview screen.

6 Check the preview image.

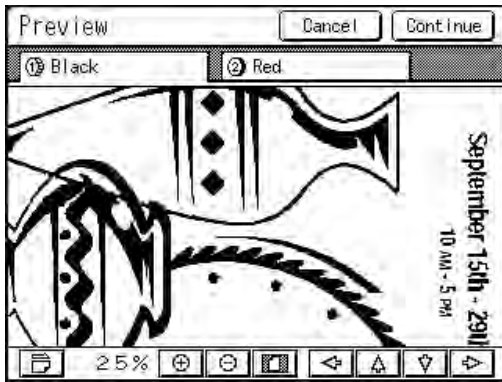

7 Touch [Continue].

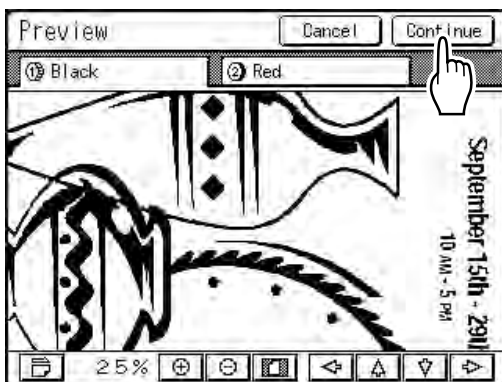

A master is created using the settings configured in step 4.

After this, please follow the same operations for normally making a master for 1-Color and 2-Color mode.

Note:

- Touching **[Cancel]** will cancel the image, returning to the Master Making Basic Screen. To resume preview operation, repeat from step 4.

Functions for Printing

Changing the Print Speed

[Print Speed Adjustment]

You can select the print speed from five levels; from 60 to 120 copies/minute. The print speed may be adjusted while printing is in progress.

Note:

- Set the default print speed on the Admin. screen.
The factory default is level 3 (approximately 100 copies/minute).
☞ p.174

Press the ◀ or ▶ key to adjust the print speed.

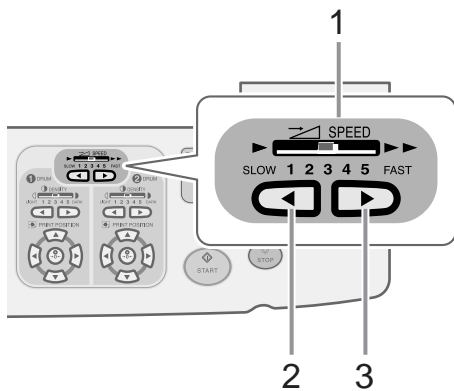

- 1) **Print Speed Indicator**
Shows the current print speed.
- 2) **▶ Key**
Increases the print speed incrementally.
- 3) **◀ Key**
Decreases the print speed incrementally.

Indicator level and print speed

Indicator Level	1	2	3	4	5	150 ppm ^{*2}
Print Speed ^{*1} (copies/minute)	60	80	100	110	120	150

*1: These are approximate ppm values.

*2: High-speed printing is set from "Functions" on the display.

Printing at High Speed [150ppm]

By using “150ppm”, you can print faster than if you were to simply adjust the “Print Speed”.

Setting “150ppm”

By registering to the Direct Access area, you can set “150ppm” by a single touch during a printing process.

☞ p.182

“150ppm” cannot be used in the following cases:

- When Printing with Letter, A4, B5 sizes, using only Cylinder (Drum) 2 for 1-Color printing
- When used in an environment in which the temperature is less than 59°F (15°C).

Important!:

- Use the normal print speed adjustment (1 to 5) until the internal temperature of the machine is higher than 59°F (15°C). The time it takes for the internal temperature to rise depends upon the machine environment.

1 Touch [Functions] on the Master Making Basic Screen or the Print Basic Screen.

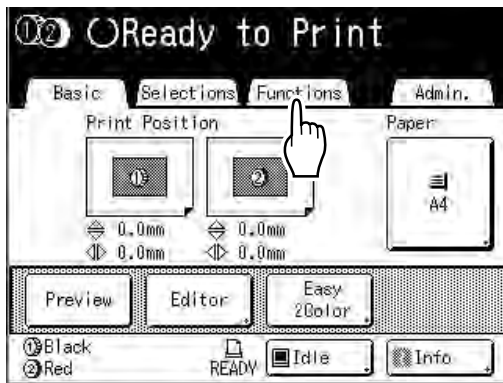

Note:

- To slow down printing speed from “150ppm”, press the ◀ key on “Print Speed” adjustment keys/indicator.

2 Touch [150ppm].

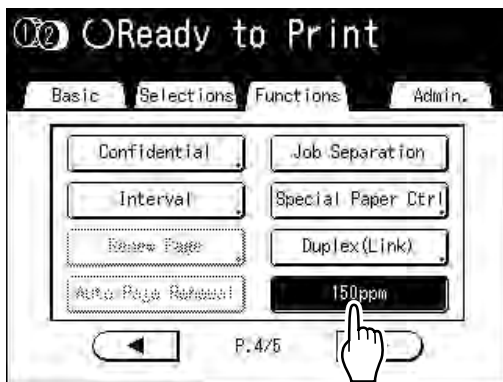

150ppm setting is updated.

Adjusting the Print Density

[Print Density Adjustment]

You can select the print density from five levels, by each cylinder (drum).
The print density may be adjusted while printing is in progress.

Important!:

- “Print Density” is not available when **[Ink Saving]** is selected.
☞ p.86

Note:

- The default print density can be set on the Admin. screen.
The factory default is set at level 3 (Standard).
☞ p.174

Press the ◀ or ▶ key to adjust the print density.

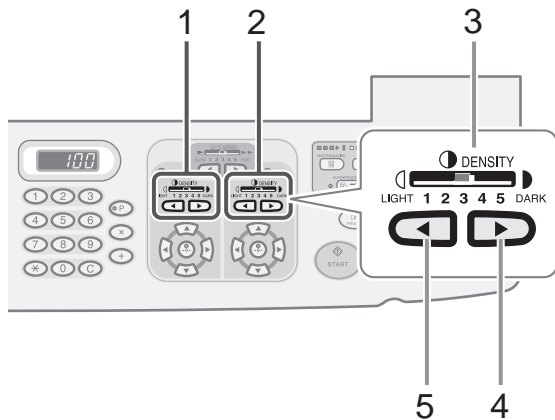

- 1) **Adjusting the print density used for Cylinder (Drum) 1**
- 2) **Adjusting the print density used for Cylinder (Drum) 2**
- 3) **Print Density Indicator**
Shows the current print density.
- 4) ▶ **Key**
Increases the print density incrementally.
- 5) ◀ **Key**
Decreases the print density incrementally.

Adjusting the Print Position

[Print Position Adjustment] [1=2 Alignment]

The print position on the paper can be adjusted for each cylinder (drum).
 Adjustment range Vertical direction: $\pm 19/32$ " (± 15 mm) Horizontal direction: $\pm 3/8$ " (± 10 mm)
 The positioning may be adjusted while Printing is in progress.

Note:

- After adjusting the print position, print a proof copy to check the result.
 p.118
- The numerical value formed by "Print Position Adjustment" is the target. Set the actual position by verifying and adjusting the printed material.
- Just after adjusting the print position of only one cylinder (drum), traces of the previous print position remain, which may cause blurred printing. If this occurs, make several proofs until the remaining image disappears.
 p.118
- When adjusting the print position of both cylinders (drums) to the same location, you can do so by simply adjusting one cylinder (drum). The other will be adjusted to the same print position.
 p.116
- Print position adjustment values for each cylinder (drum) are retained after printing is completed, to be applied for subsequent master making processes. The values will be retained until the  key is pressed or power is turned off.

Press the , ,  or  key to move up or down.

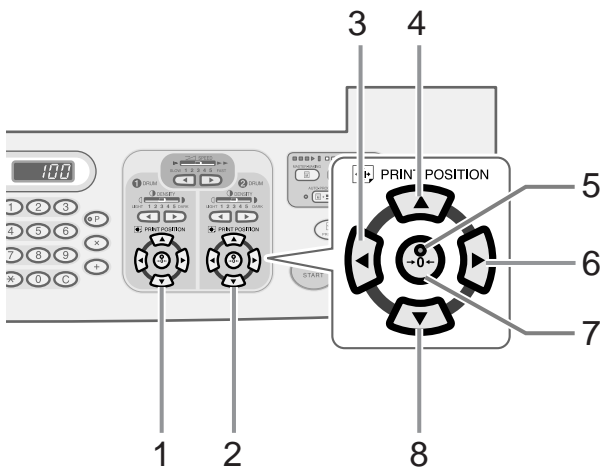

- 1) Adjusting the print location for Cylinder (Drum) 1
- 2) Adjusting the print location for Cylinder (Drum) 2

- 3)  Key
 Each press shifts the print position downward in steps of about $1/64$ " (0.5 mm).

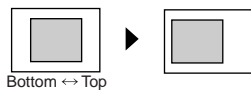

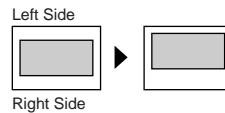

- 4)  Key
 Press the key to move the print image about $1/64$ " (0.5 mm) to the left on the paper.

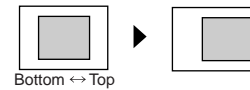

- 5) **Original Position Indicator**
 Indicates when positioning has not changed.

- 6)  Key
 Each press shifts the print position upward in steps of about $1/64$ " (0.5 mm).



- 7)  Key
 Press to return to original position.

- 8)  Key
 Press the key to move the print image about $1/64$ " (0.5 mm) to the right on the paper.

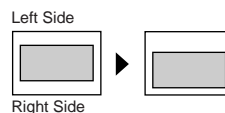

The Print Basic Screen shows current vertical/horizontal adjustment.

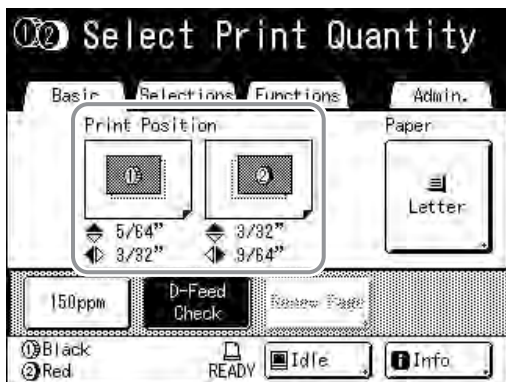

Adjusting the Print Position of Both Cylinders (Drums) Together

1 Adjust the print position of one of the cylinders (drums).

The adjustments display on the Print Basic Screen.

2 Touch [Functions] on the Print Basic Screen.

Ex: When adjusting Cylinder (Drum) 1

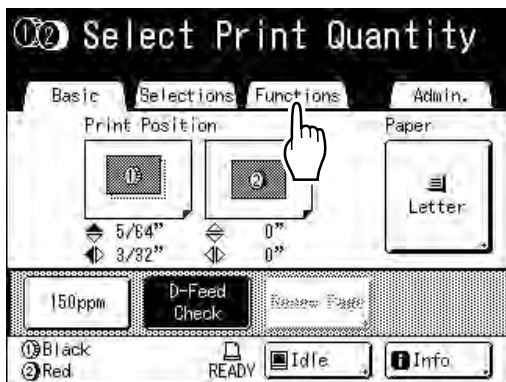

3 Touch [1=2 Alignment].

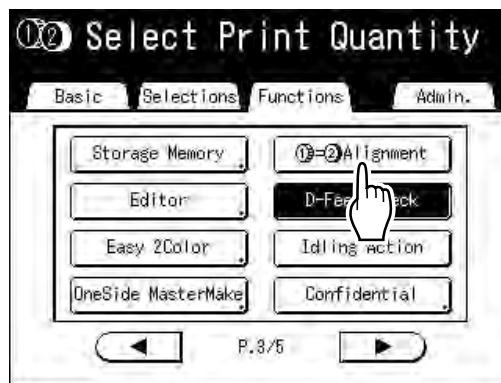

The other cylinder (drum) is adjusted to the same print position.

4 Touch [Basic] to check the Print Basic Screen.

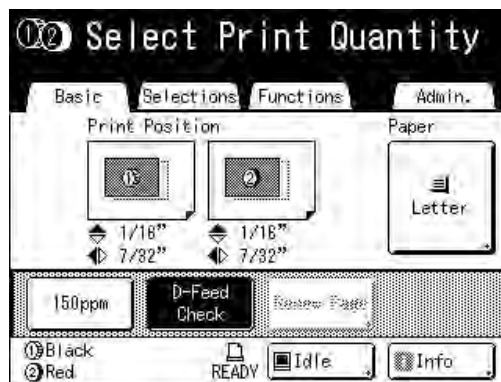

Note:

- If both cylinders (drums) were adjusted separately, it is adjusted to match the position of the last-adjusted cylinder (drum).

Tip:**Making Fined Adjustments to the Print Position**

If the settings are such that "Fine Adjust Mode" can be set, the print position can be finely adjusted in $1/254$ " (0.1 mm) increments (the normal increment is $1/64$ " (0.5 mm)).

Note:

If you want to use "Fine Adjust Mode", please contact your dealer (or service/maintenance provider).

[Fine Adjust Mode] is displayed on the Functions screen if "Fine Adjust Mode" can be used.

If you press and highlight (in b/w) **[Fine Adjust Mode]**, "Fine Adjust Mode" is activated and you can make print position adjustments in increments of $1/254$ " (0.1 mm). The increments return to $1/64$ " (0.5 mm) when set to "OFF".

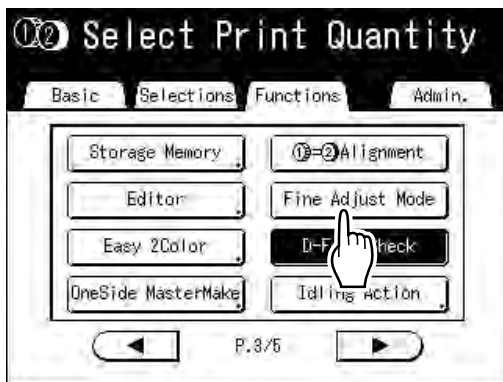

Printing Proof Copies [Proof]

After making adjustments to the print position or density, check the print quality in a proof copy. Proof copies are not counted towards the number of copies displayed on the Print Quantity Display.

Note:

- The machine will continue to print proof copies if the  key is held down.
- A proof copy cannot be printed from a Linked Printer (sold separately).

Press the  key.

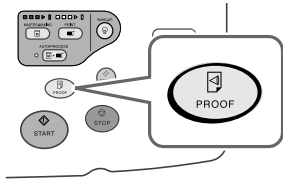

A single proof copy is printed.

Prevent Paper Jams When Using Special Paper [D-Feed Check]

This printer monitors for multiple paper feeds. If a feed of more than one sheet is detected, the print job automatically stops and “D-Feed Check” is executed.

The multiple paper feed detector is calibrated for normal print paper. Paper jams or errors may be displayed depending upon the type of paper used. In the following instances, please set “D-Feed Check” to “OFF”.

- When a multi-feed detection message is occasionally displayed, even though no multi-feed has occurred
- When using dark paper (black, red, dark blue)
- When using paper already printed on the back side

Note:

- In the factory setting, “D-Feed Check” is set to “ON”.
 ↪ p.174

1 Touch [Functions] on the Print Basic Screen.

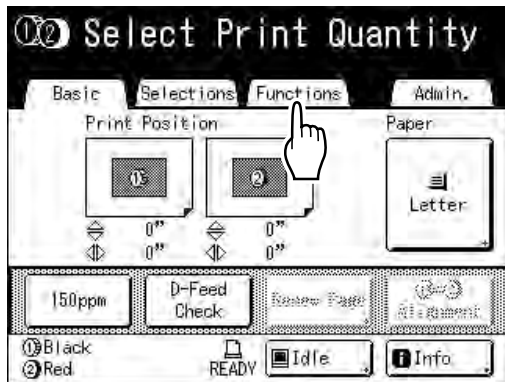

2 Touch [D-Feed Check].

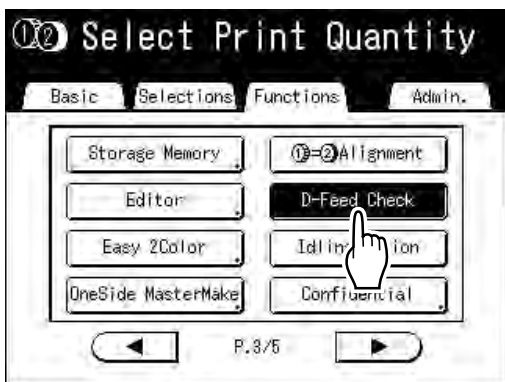

The button changes from being highlighted (b/w) to the normal display, and “D-Feed Check” is set to “OFF”.

Keeping Printed Copies Dry [Interval]

By allowing the cylinder (drum) to skip a rotation during printing and extend the printed paper ejection interval, the ink has time to dry, preventing it from leaving marks on the back of the next sheet.

Skip Rotation can be set from 1-10.

1 Touch [Functions] on the Print Basic Screen.

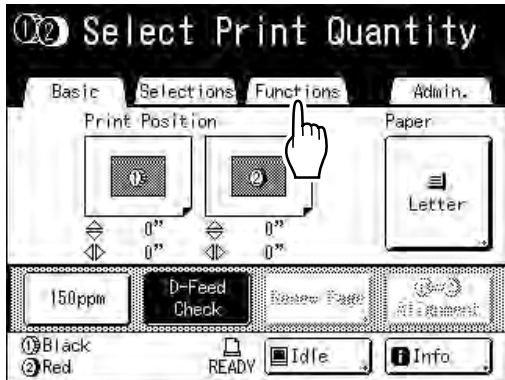

2 Touch [Interval].

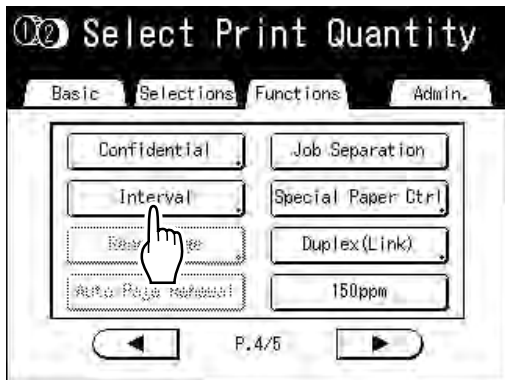

3 Touch [ON].

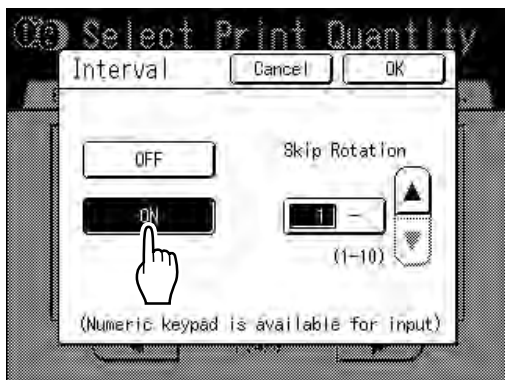

4 Touch [▲] or [▼] to set the number of Skip Rotations for the Print Cylinder (Drum).

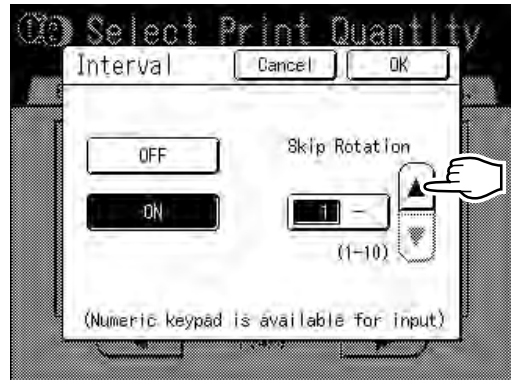

Note:

- Print Quantity Keys can also be used to enter numbers.
- If you are using extended paper and set the cylinder (drum) skip rotation to an odd number, the actual skip rotation is the "Set Number +1".
 ↪ p.188

5 Touch [OK].

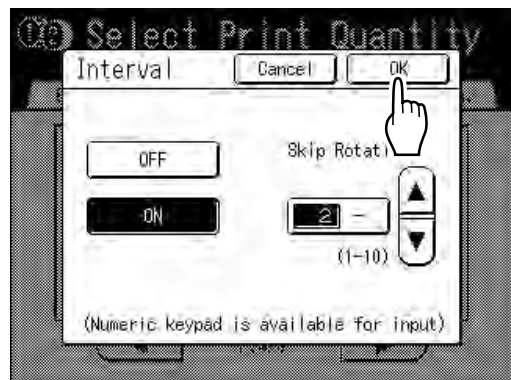

The following screen appears.

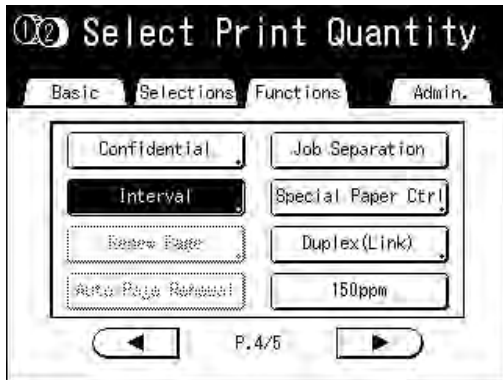

Returns to the Functions screen. Interval setting is updated.

Paper Feed/Output Settings for Special Paper and Printing Types

[Jump Wing Control] [Special Paper Ctrl]

Paper feed and output settings can be adjusted when using special paper or uneven print finishes.

◆ Jump Wing Control

The following steps retrieves pre-configured custom settings for the Paper Jumping Wing. Use this feature to eject certain printing paper that is hard to eject with automatically adjusted normal Paper Jumping Wing setting.

Important!:

- “Jump Wing Control” feature is not available unless pre-configured.
- Only one setting can be pre-configured.
- To pre-configure or to change settings, please contact your dealer (or authorized service representative).

Note:

- The Paper Jumping Wing is a device which helps eject printed paper onto the Auto-control Stacking Tray or the Paper Receiving Tray. It automatically adjusts according to the position of the Paper Feed Pressure Adjustment Lever (standard or thick).

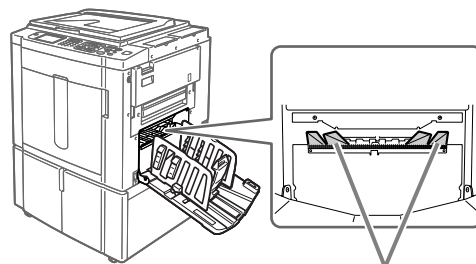

Paper Jumping Wing

◆ Special Paper Ctrl

You can save settings for easy retrieval next time. The “Special Paper Ctrl” menu contains the following options:

Paper Feed Adj.

Adjust Standard Feed Tray position and paper-feed amount to suit special paper characteristics. For adjustment methods, please contact your dealer (or authorized service representative).

Paper Eject Adj

Some types of original image/paper may be printed with an uneven or blurred finish due to air blow or separation fan settings. This option can be used to change air blow, separation fan settings. For adjustment methods, please contact your dealer (or authorized service representative).

Setting the Jump Wing Control [Jump Wing Control]

- 1 Touch [Functions] on the Print Basic Screen.

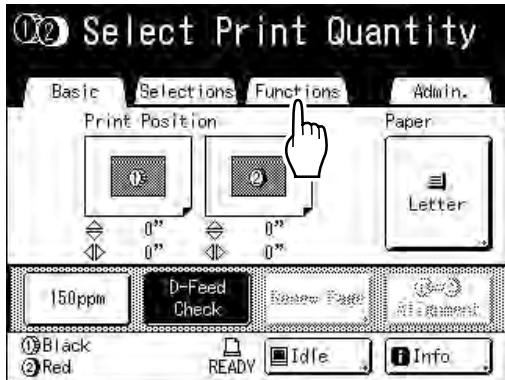

- 2 Touch [Jump Wing Control].

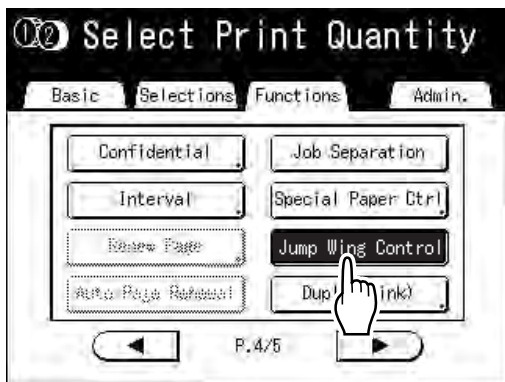

“Jump Wing Control” is selected.

Retrieving Settings from the Parameter List

1 Touch [Functions] on the Print Basic Screen.

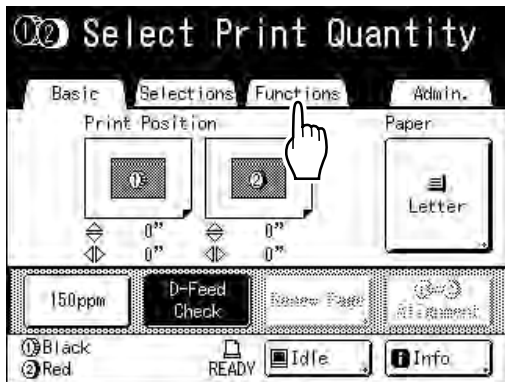

2 Touch [Special Paper Ctrl].

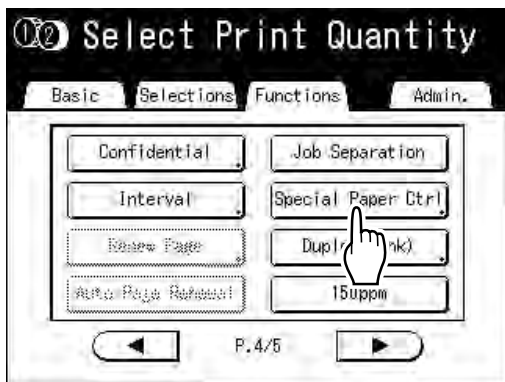

3 Touch [Entry/Call].

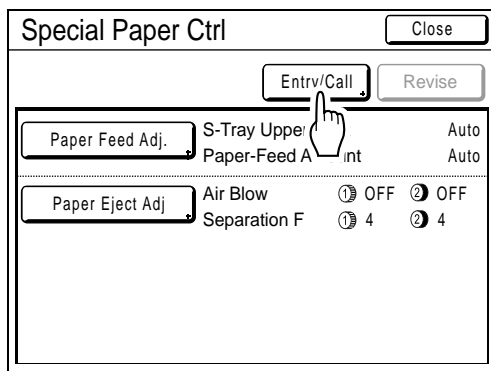

Display the Parameter List screen.

4 Touch [Retrieve].

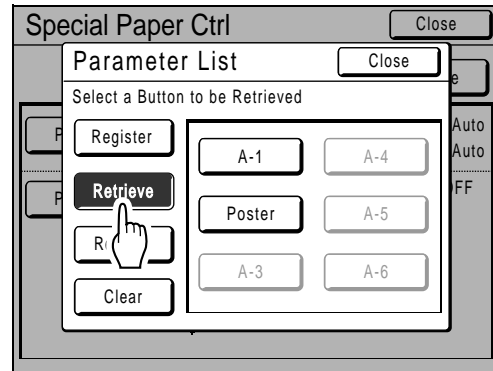

5 Touch the button to retrieve.

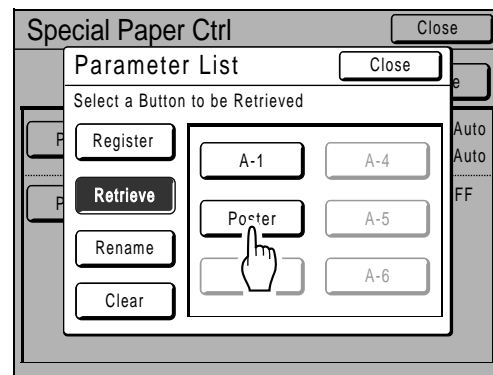

Grayed-out buttons are not available (no setting has been registered yet). Returns to the Special Paper Ctrl screen and the desired setting is retrieved. Confirm the settings made.

Note:

- Repeat steps 3 to 5 to retrieve other settings.

6 Touch [Close].

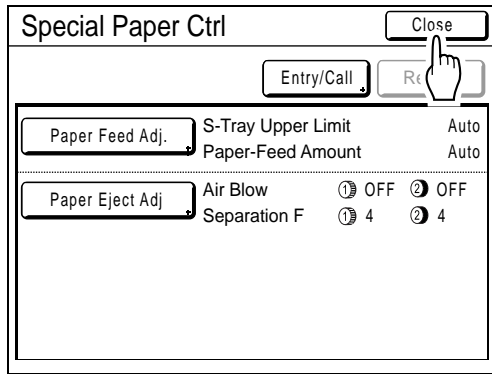

Returns to the Functions screen and the settings are updated.

(Retrieve the settings to confirm, and follow the steps beginning with step 2.)

Saving settings in the Parameter List

- 1 Touch [Functions] on the Print Basic Screen.

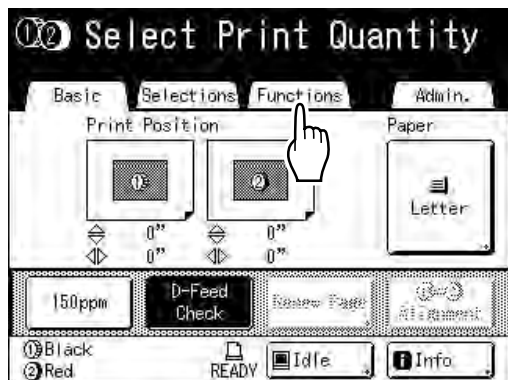

- 2 Touch [Special Paper Ctrl].

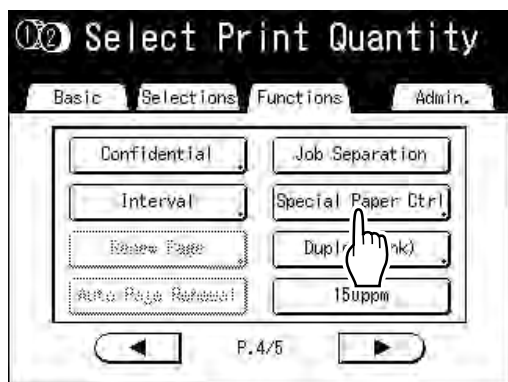

- 3 Adjust [Paper Feed Adj.] and [Paper Eject Adj].

Note:

- For details of adjustments, see p.122.

- 4 Confirm the adjustments on the Special Paper Ctrl screen.

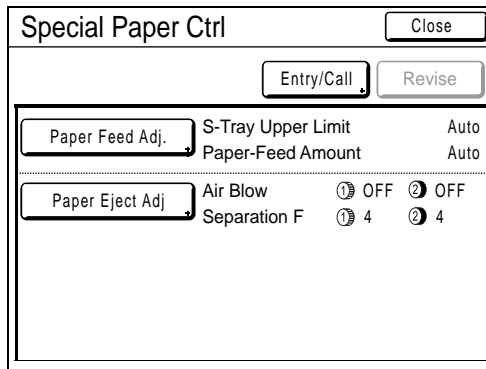

- 5 Touch [Entry/Call].

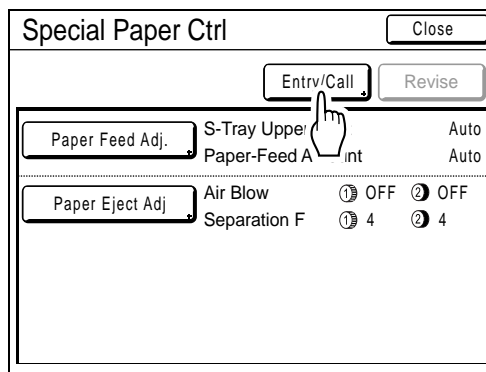

Parameter List screen is displayed.

- 6 Touch an unused button.

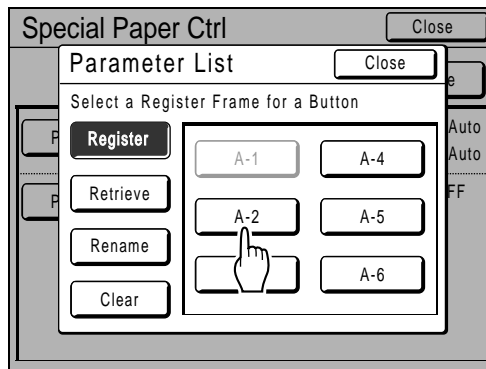

Unused buttons are displayed with a solid line. Grayed-out buttons are not available (associated with another setting).

7 Touch [OK].

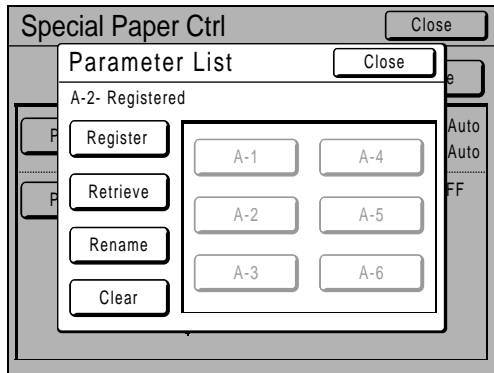
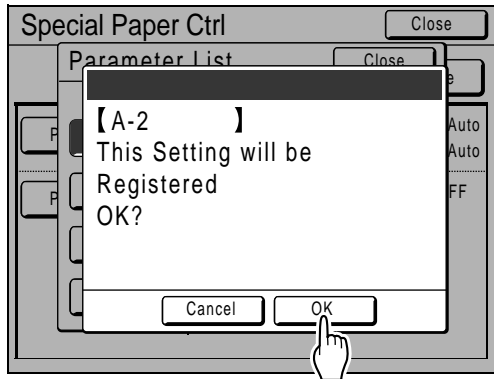

Returns to the Parameter List after the settings have been saved.
The name of each parameter can be changed for your convenience. To change parameter names, see the step 8.

Note:

- After saving the settings, touch **[Close]** on the Parameter List screen to return to the Special Paper Ctrl screen.
- Touch **[Close]** on the Special Paper Ctrl screen to return to the Functions screen. Printing will be done with the saved settings.

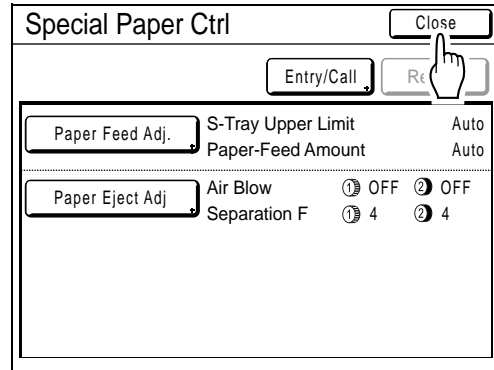

- If you do not wish to print after saving the settings, press  on the control panel.

8 Touch [Rename].

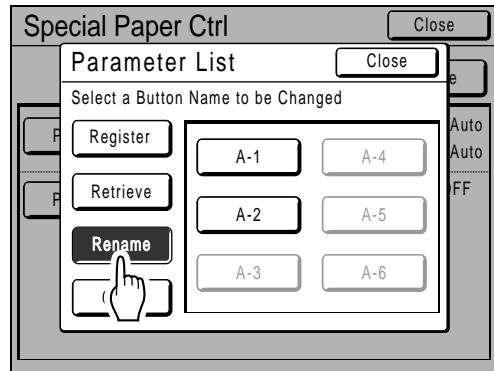

9 Touch the button to rename.

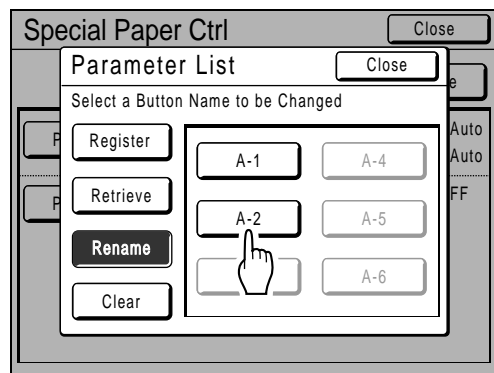

Grayed-out buttons are not available (no setting has been registered yet).

10 Touch character buttons to enter a new name.

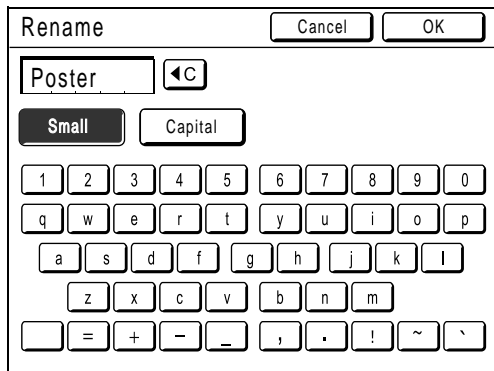

Change capitalization by selecting **[Small]** or **[Capital]** button.

☞ p.142

11 Touch [OK] after entering all the characters.

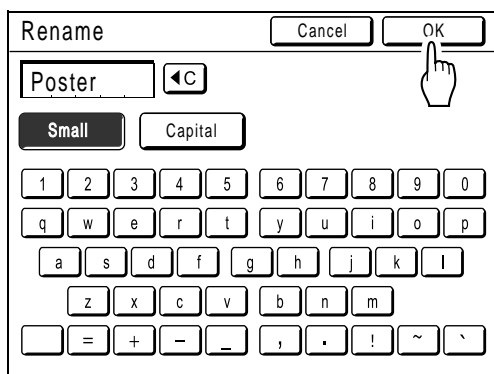

Returns to the Parameter List screen and the name is updated.

12 Touch [Close].

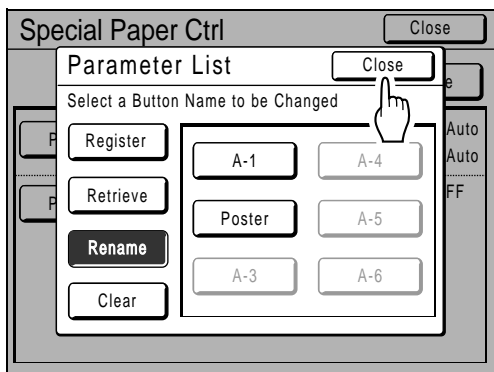

Returns to the Special Paper Ctrl screen.

Making changes to Special Paper Ctrl Setting

1 Display the Parameter List screen.

Follow steps 1 to 3 (p.124).

2 Touch [Retrieve].

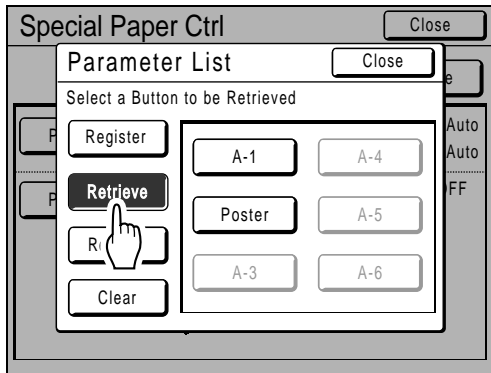

3 Touch the button to change.

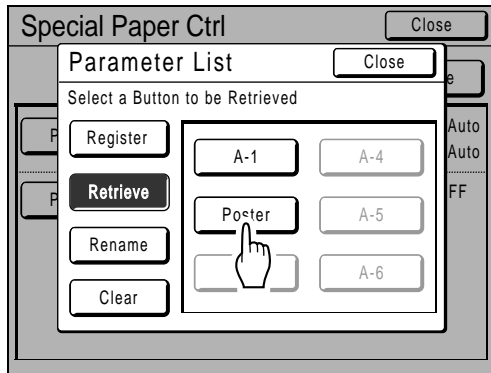

4 Change the setting parameters.

Parameters for the following can be changed: "Paper Feed Adj." and "Paper Eject Adj".

Note:

- For details of changes, see p.122.

5 Touch [Revise] on the Special Paper Ctrl screen.

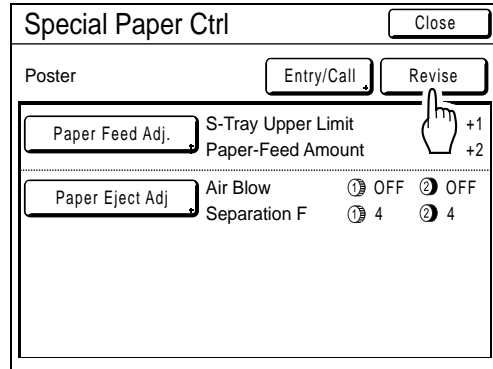

6 Touch [OK].

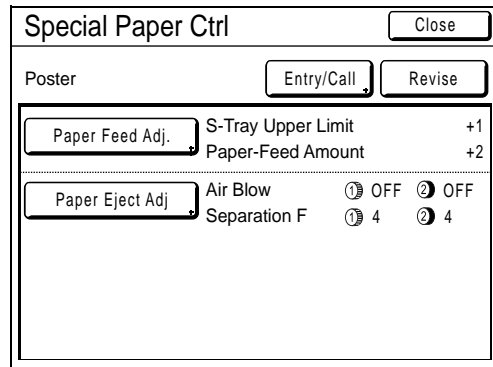
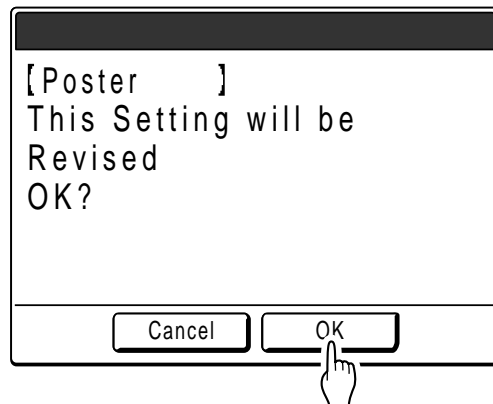

Returns to the Special Paper Ctrl screen after parameters have been revised.

Clearing Special Paper Ctrl Settings

1 Display the Parameter List screen.

Follow steps 1 to 3 (p.124).

Important!:

- First, check whether the setting can be cleared. (Retrieve the appropriate setting and follow the steps beginning with step 2.)
- Cleared settings cannot be recovered.

2 Touch [Clear].

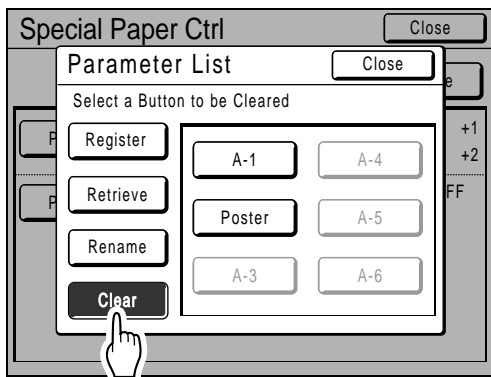

3 Touch the button for the setting you want to clear.

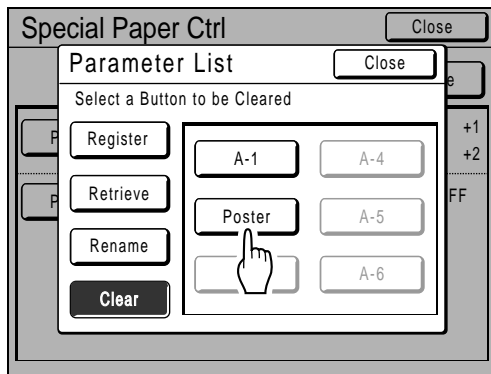

Grayed-out buttons are not available (no setting has been registered yet).

4 Touch [OK].

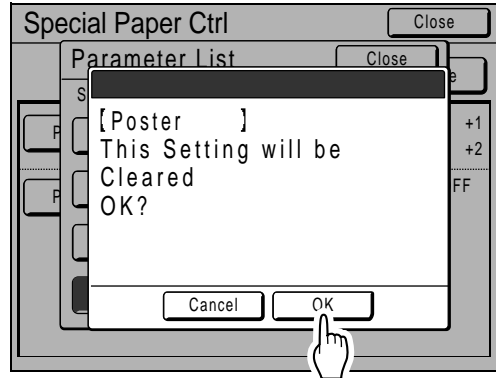

Returns to the Parameter List screen. The selected setting is cleared.

5 Touch [Close].

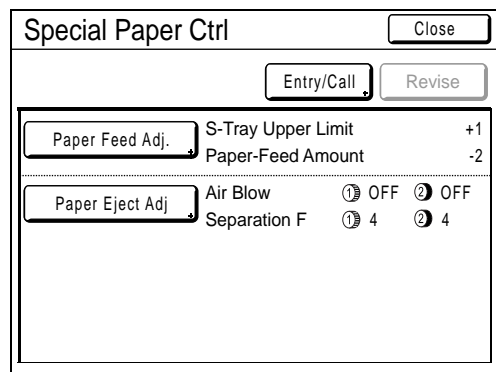
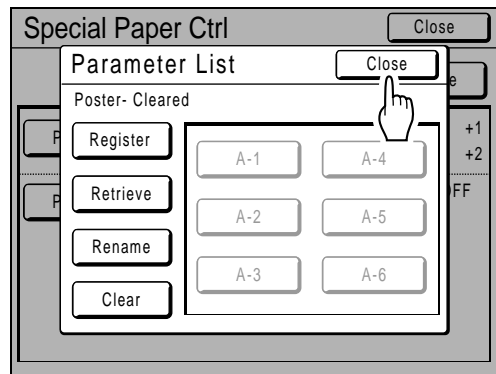

Returns to the Special Paper Ctrl screen.

Advanced Features

Automatic Sorting Into Groups [Program]

You can use “Program” to divide one original into several groups and program each group to print a different number of copies or sets. For multiple originals, you can change the number of copies for each original and then print. “Program” consists of three types: “Single Page”, “Multi-Page”, and “Combination”.

Once a setting has been programmed, it can be registered to the Program List and can be retrieved and repeatedly used (up to 12 programs of the combined 3 groups can be stored)

Note:

- After printing with “Program”, press the  key to deactivate “Program”.

◆ Single Page Mode

From a single original document, print into multiple groups of sets.

A maximum of 50 groups can be created, each having up to 99 sets. Each set can be up to 9999 copies.

The machine can be configured to specify how many copies (sheets) per set, then how many sets are to be created for each group.

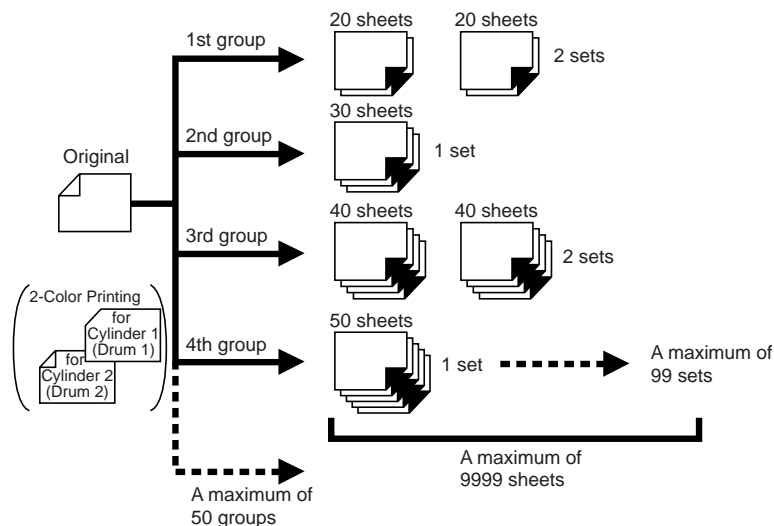

Important!:

- If you are printing multiple originals with “Single Page” program, place multiple originals (up to 50) in the ADF unit (option), and as long as “Auto Process” is “ON”, the set program can be repeated and all the originals are divided into groups to print the various number of copies specified.

◆ Multi-Page Mode

For multiple originals (multiple copies for 1-Color printing, multiple groups of 2 originals for 2-Color printing), a different number of copies are printed for each original.

From a single original, up to 9999 copies can be made.

Each original can reproduce a pre-assigned number of sheets (up to 20 originals).

1-Color Printing

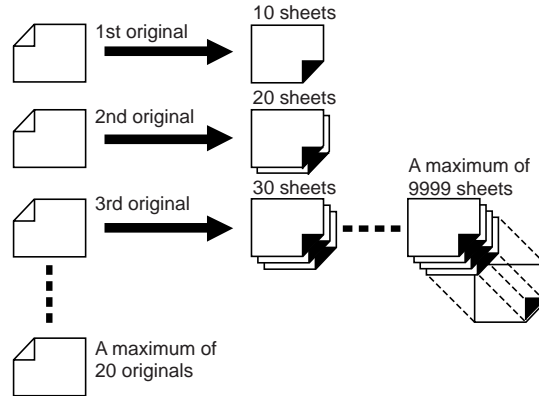

2-Color Printing with 2 Originals

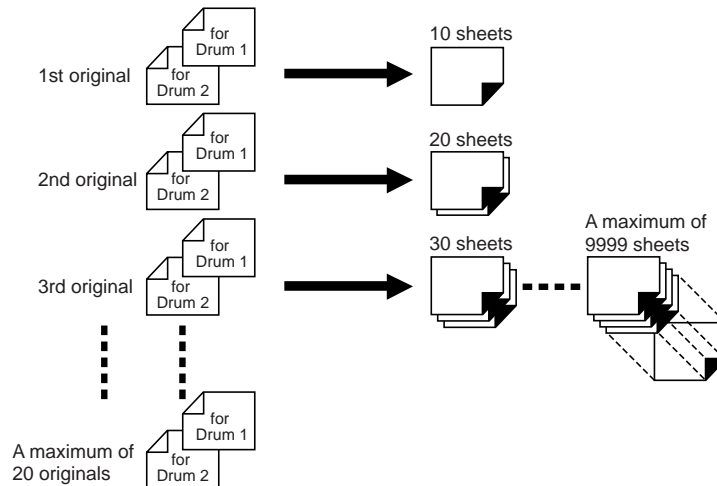

Note:

- This function cannot be used for printing from a computer data (direct print).
- “Program” may be used in conjunction with the “Easy 2Color” in 2-Color printing.

◆ **Combination (only possible with 2-Color printing)**

A 2-Color original is used to make a master on Cylinder (Drum) 1 and Cylinder (Drum) 2. The 1-Color print for just Cylinder (Drum) 1 is grouped in the same way as for “Single Page” program and prints. The 2-Color print object is inserted based upon the copy number set as the group separation.

The “Combination” program is useful for printing material that has “Questions” and “Answers”.

For example, it can be used to print multiple test questions for students in one color and then print one copy of the teacher’s answer key in red.

Up to 50 groups can be set, and each group can have a maximum of 9999 copies.

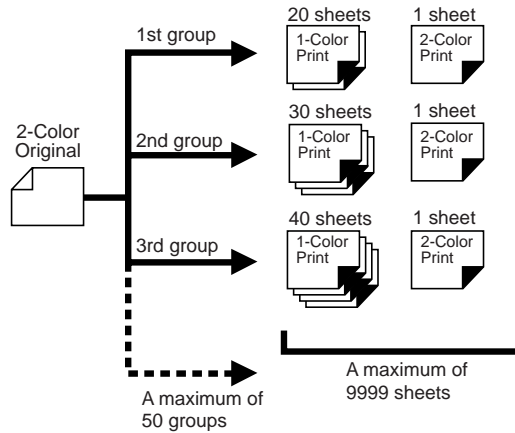

Important!:

- The “Combination” program is a function for setting the number of print copies. It is not intended to separate colors into red and black. Use “Easy 2Color” for this. (p.146)

How to Program Print

There are two ways to print in sets using “Program” printing feature.

- Program, then print (without saving the settings)
- Retrieve a saved program, then print (when program is registered)

Tip:

Choose from the following actions on the Print Basic Screen.

Touch a button to proceed.

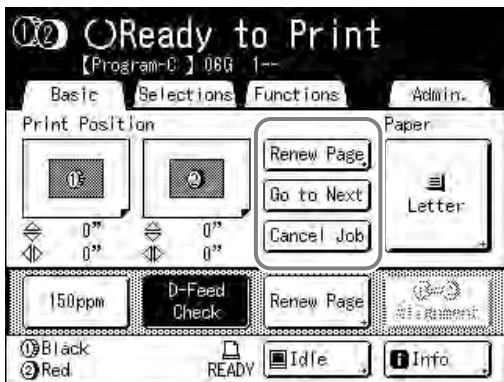

[Renew Page]: Creates a master from the last Master-Making data.

[Next Page] or **[Go to Next]:** Stops current print job, skips to the next original, set or group.

[Cancel Job]: Cancels execution of the Program.

Note:

- The Job Separator (option) is useful for Programed Printing.
The Job Separator releases a piece of tape after each set or original document, thereby automatically separating sets or groups. It eliminates the need to manually remove a stack of sheets or insert a marker between sets. Remember to activate “Job Separation” in the Functions screen when printing with the Job Separator. You must remove each stack from the Paper Receiving Tray, or insert a marker during the pause if not using the Job Separator.

Setting Up for Programed Printing



Note:

- Both the Touch Screen and Print Quantity Keys (and related keys) may be used for this operation.

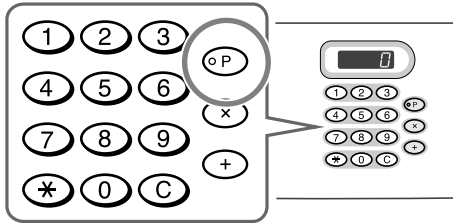
1 Press the  key.



Note:

- Press the  key and skip to step 3) of the “Single Page Mode”. Press the  key and skip to step 3) of the “Multi-Page Mode”.
- Alternatively, from the Master Making Basic Screen, touch [Functions] then [Program] to display the Program Type screen.

2 Touch the button of the program to set.

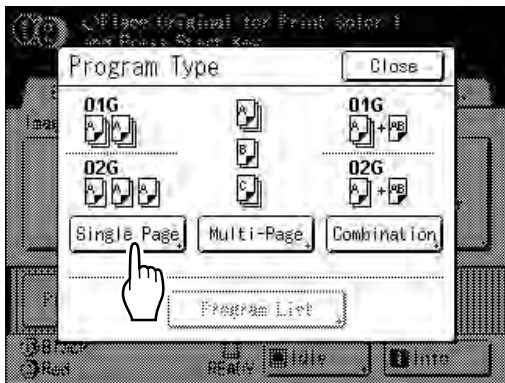



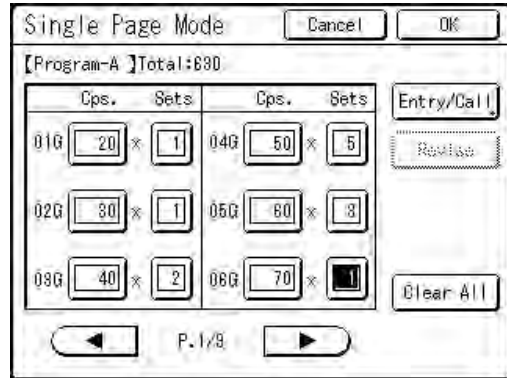

The input screen for that program displays.

3 Enter the numbers using the Print Quantity Keys.

◆ For Single Page Mode



- 1) Enter the number of copies using the Print Quantity Keys.
- 2) Press the  key or the  key.
- 3) Enter the number of sets (in the group) using the Print Quantity Keys.
- 4) Press the  key or the  key.

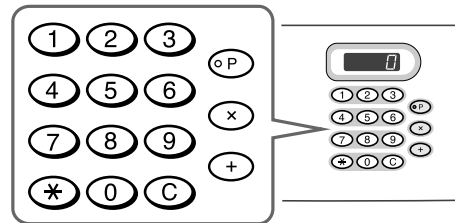

To program more than one group, repeat steps 1) - 4).

Note:

- Touch the desired input box. You can input the page/set number with the Print Quantity Keys.
- To cancel or change a number, press the  key and enter again.
- To clear all (number of copies and number of sets), touch [Clear All].
- The total number of all copies to be printed is shown on the top of the screen.

Important!:

- To save the current Programed Printing setting, touch **[Entry/Call]**.
Once **[OK]** is touched, the setting cannot be saved. See “Saving Programs” (p.139) for further information.

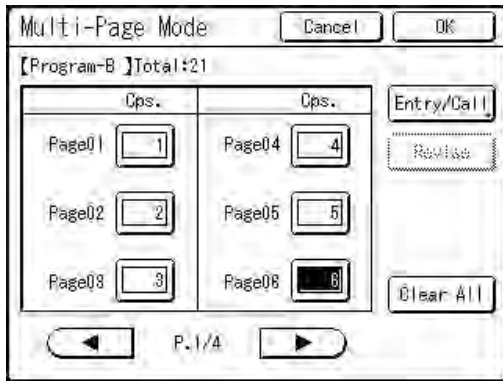
◆ For Multi-Page Mode

- Enter the number of copies using the Print Quantity Keys.
- Press the **(+)** key or the **(*)** key.
- Repeat steps 1) and 2) above to enter the number of copies for each original.

Note:

- Touch the desired input box. You can input the page/set number with the Print Quantity Keys.
- To cancel or change a number, press the **(C)** key and enter again.
- To clear all (number of copies and number of sets), touch **[Clear All]**.
- The total number of all copies to be printed is shown on the top of the screen.

Important!:

- To save the current Programed Printing setting, touch **[Entry/Call]**.
Once **[OK]** is touched, the setting cannot be saved.
See “Saving Programs” (p.139) for further information.

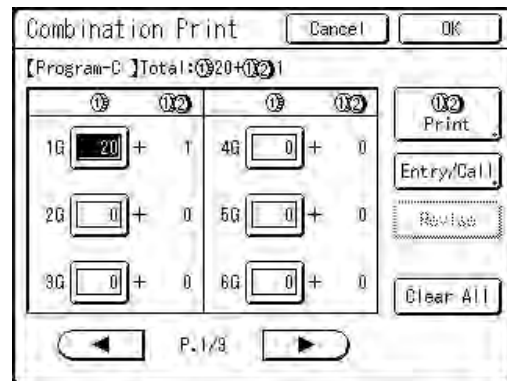
◆ For Combination Print

- Enter the number of copies using the Print Quantity Keys.

Note:

- If you specify “Combination” program when using direct print to print a job with multiple pages, the first page stops prior to printing. Use the control panel to input the number of print copies to print. The remaining pages are handled as follows:

When “Auto Print” is set to “Semi-Auto(Master)” or “Manual” (Auto Process OFF):



Subsequent pages also stop prior to printing. Press the **(START) key after confirming the settings on display.**

When “Auto Print” is set to “Semi-Auto(Print)” or “Full Auto” (ON):

Printing does not stop for subsequent pages. Pages print at the setting specified for the first page.

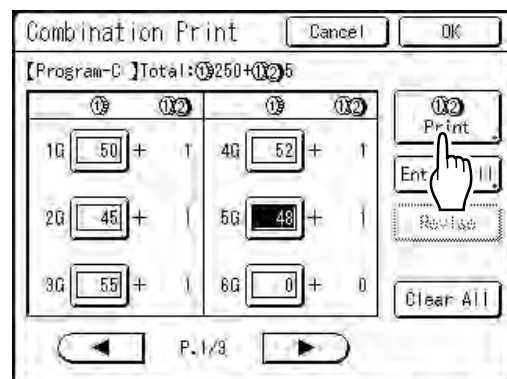
- When using 2-Color printing to print two or more copies, touch **[1] [2] Print**. This operation is not required if you are only printing one 2-Color copy.



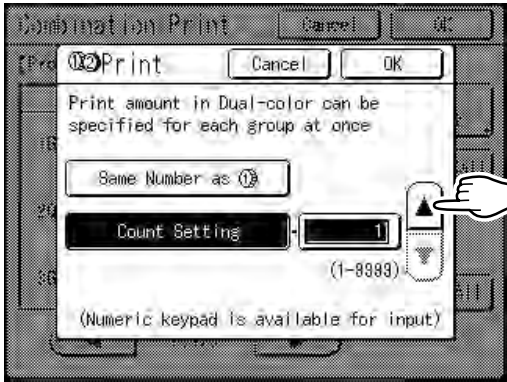

- 3) Touch  or  to specify the number of 2-Color copies to print.



Note:

- Alternatively, after entering number of copies or sets, press the  key to start printing without touching [OK].

Note:

- The Print Quantity Keys can also be used to enter a value.
- The number of copies assigned for “  Print” will apply to all groups and cannot be changed from group to group.
- If you are printing the same number of 2-Color copies as 1-Color copies, touch **[Same Number as **].

- 4) Touch [OK] and the Print screen closes.

Important!:

- To save the current Programed Printing setting, touch **[Entry/Call]**. Once [OK] is touched, the setting cannot be saved. See “Saving Programs” (p.139) for further information.

4 Touch [OK].

The following screen appears.



Returns to the original screen. Ready to print in accordance with the program.

Saving Programs

Store frequently-used Program settings for later retrieval and printing.

A total of 12 settings (Single Page Mode, Multi-Page Mode Mode or Combination Print) can be stored.

1 Create and enter a Programed Printing settings.

Follow steps 1-3 in "Setting Up for Programed Printing" (p.136).

2 Touch [Entry/Call] on the Program screen.

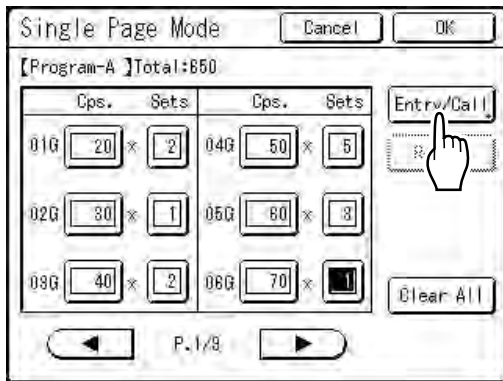

3 Touch an unused button.

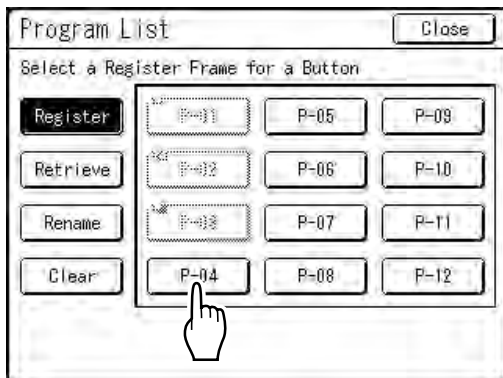

Touch a button displayed with solid lines. Grayed-out buttons are not available (already associated with another program).

4 Touch [OK].



The following screen appears.

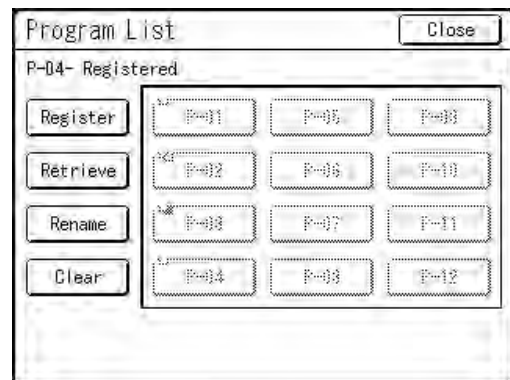

Returns to the Program List screen. The Program is stored.

Each Program can be named for your convenience. See step 3 in "Renaming a Program" (p.141).

Note:

- After saving the Program, touch **[Close]** on the Program List screen to return to the Program screen.

Touch **[OK]** on the Program screen to print from a saved Program.

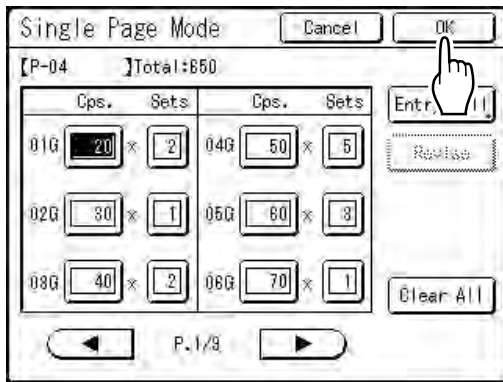

Renaming a Program

Program names can be changed to better describe their usage or purpose.

1 Touch [Program] on the Functions screen.



Note:

- If [Program] is already highlighted, touching it will again display the Program screen, and not the Rename a Program screen. Touch [Cancel Job] then [OK] to return to Functions screen. Touch [Program] again.

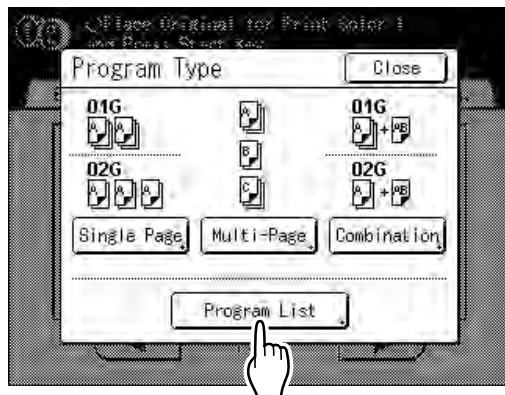

2 Touch [Program List].

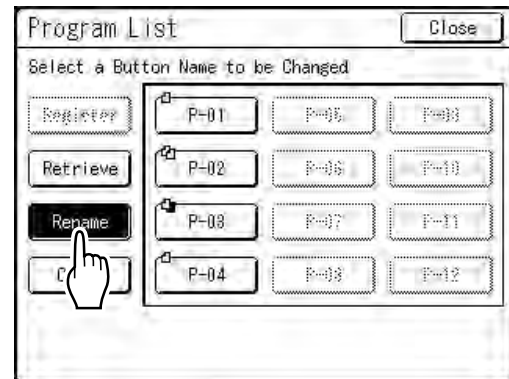

3 Touch [Rename].



Note:

- Each Program button has an icon on top left.  indicates Single Page Mode Program,  indicates Multi-Page Mode Program and  indicates Combination Print.

4 Select a program to rename.

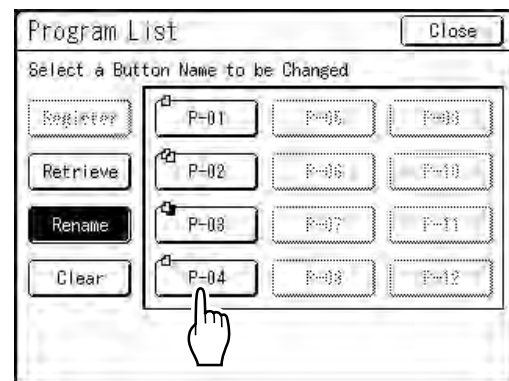

5 Touch **⌫** to delete the current name

Note:

- You can also press the **Ⓢ** key to delete.

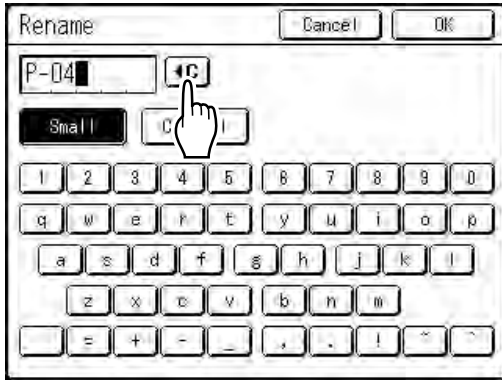

6 Touch character buttons to enter a new name.

Change capitalization by selecting **[Small]** or **[Capital]** button.

☞ p.142

7 When entered, touch **[OK]**.

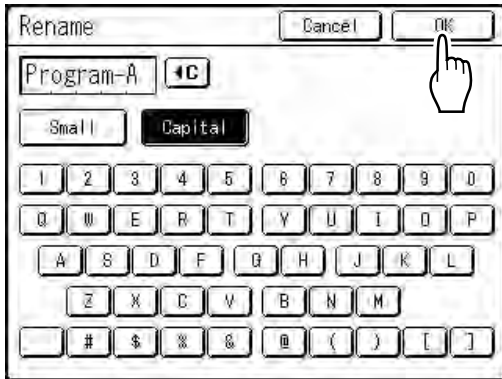

The following screen appears.

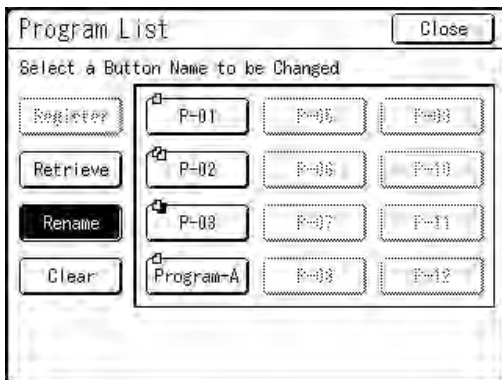

Returns to the Program List screen. The program is renamed.

Tip:
Rename Screen

◆ **Small**

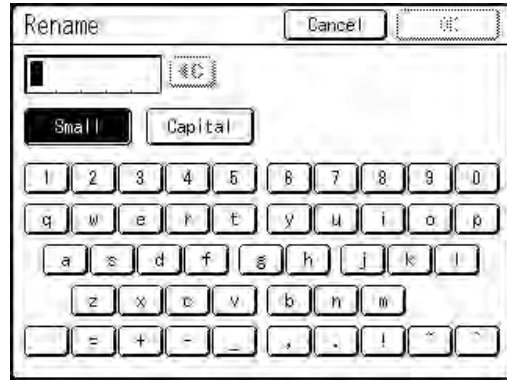

◆ **Capital**

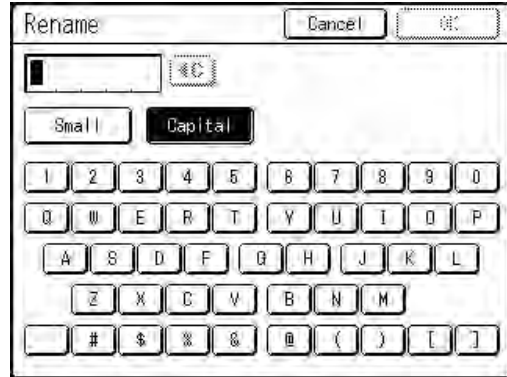

Note:

- You can enter up to 10 characters.
- Print Quantity Keys may also be used for entering numbers.
- ⌫** button clears previously saved or current entry. Touch to clear one character at a time.

Clearing Programs

1 Press the **P** key.

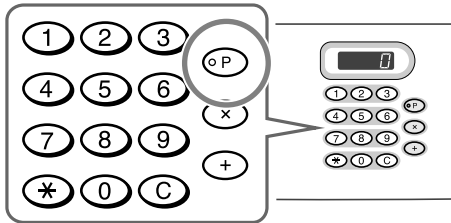

Note:

- Alternatively, from the Master Making Basic Screen, touch **[Functions]** then **[Program]** to display the Program Type screen.

2 Touch **[Program List]**.

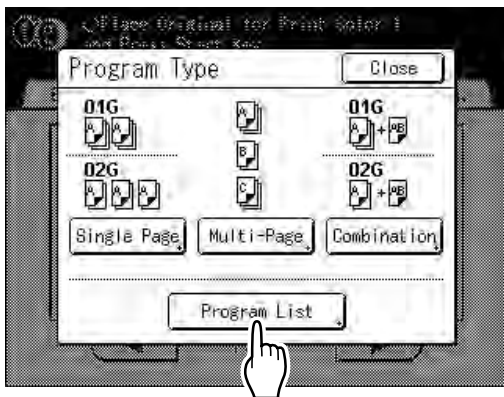

3 Touch **[Clear]**.

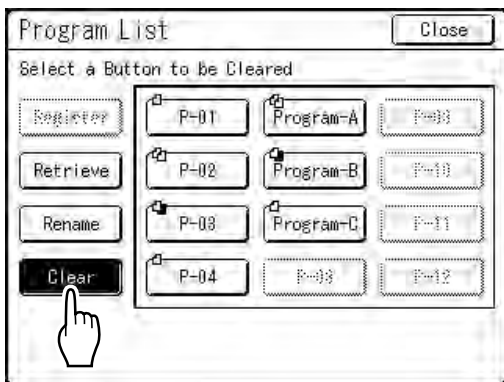

4 Select a program to delete.

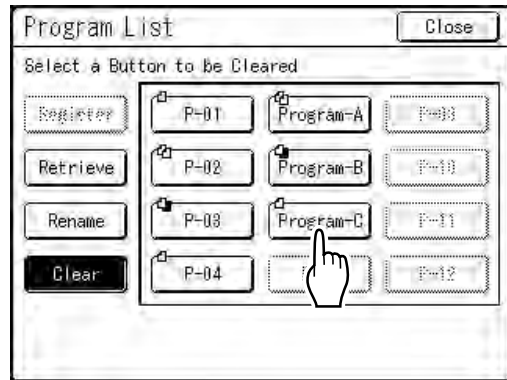

5 Touch **[OK]**.



The following screen appears.

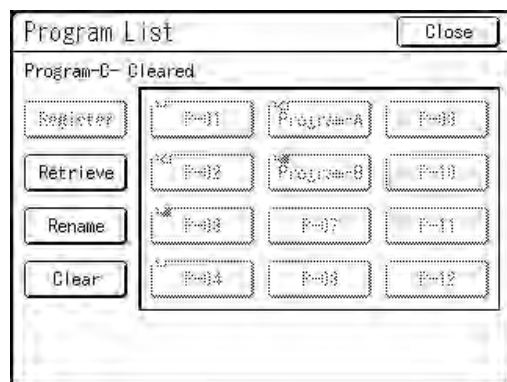

Returns to the Program List screen. The program is deleted.

Retrieving a Program

Retrieve a stored program and modify its settings.

1 Press the  key.

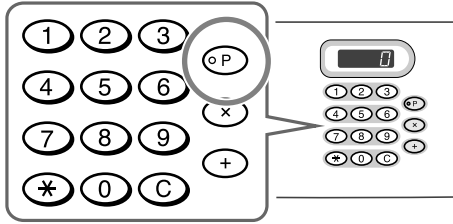

Note:

- Alternatively, from the Master Making Basic Screen, touch [Functions] then [Program] to display the Program Type screen.

2 Touch [Program List].

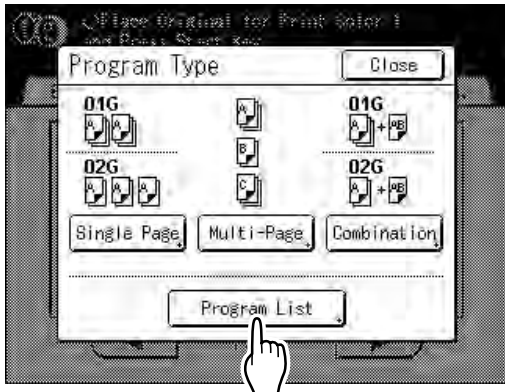

3 Touch a button to select a Program to retrieve.

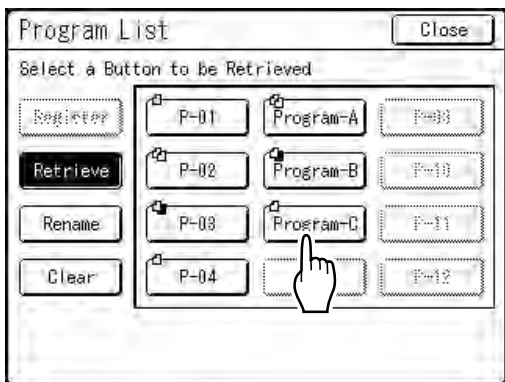

Note:

- When printing with 1-Color, the "Combination" program cannot be retrieved.

4 Touch [OK].

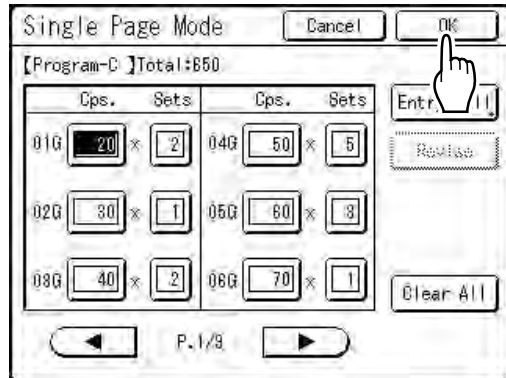

The following screen appears.



Returns to the original screen. Ready to print using the retrieved program.

Making changes to Stored Programs

- 1 Retrieve a program to modify.**
Follow steps 1 and 3 in “Retrieving a Program” (p.144).
- 2 Make changes to the Program.**
Modify number of copies or sets in the current screen.
Note:
 - See “Setting Up for Programed Printing” (p.136) for details on how to set up a program.
- 3 Touch [Revise].**

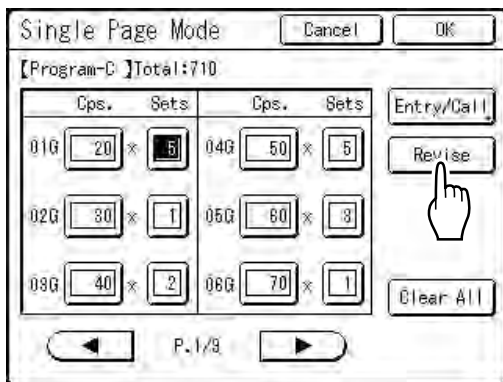

- 4 Touch [OK].**



The following screen appears.

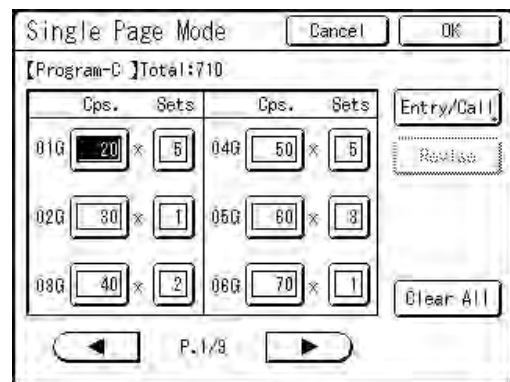

Returns to the Program screen. Program settings are updated (overwritten).

Programming Example

Printing questions and answers divided by class

This example uses “Easy 2Color” and “Program” together.

The original is a sheet of paper with test questions (black, 1 color) with the answers written in using a recommended pen. 5 groups are printed using the following conditions.

- For use by the student, by each group (class): Group 1: 50 copies, Group 2: 45 copies, Group 3: 55 copies, Group 4: 52 copies, Group 5: 48 copies. The printed document consists of the one-color problem sheet.
- 2 copies of the answers written in with the questions (2-Color Print) are inserted between each set.

The colors are separated using “Easy 2Color” — “Hand Writing--1” and the job prints as a combination.

1 Place an original and load paper.

“2-Color Printing with 1 Original [Easy 2Color]”
(p.46)

2 Setting [Hand Writing--1].

1) Touch [Functions].

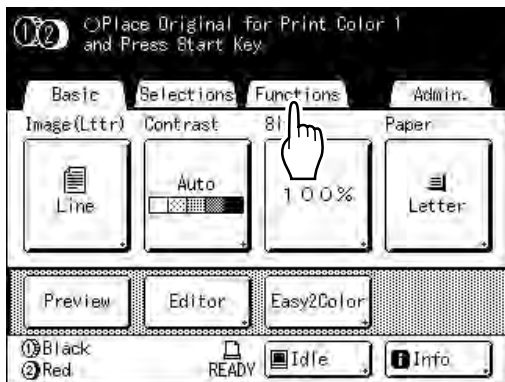

2) Touch [Easy 2Color].



3) Touch [Hand Writing--1].

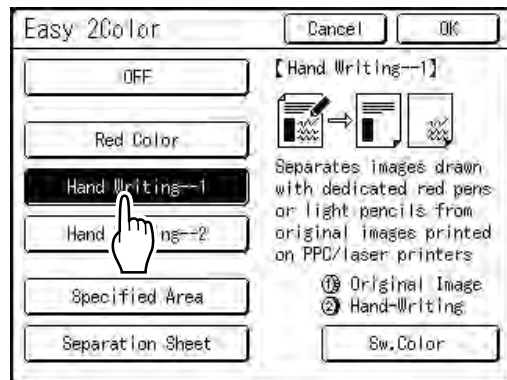

4) Touch [OK].

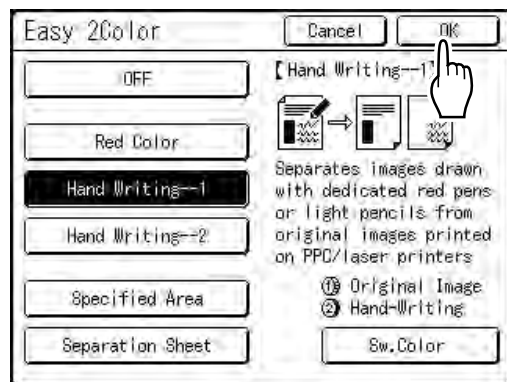

Returns to the Functions screen.



3 Setting [Combination].

1) Press the **Ⓟ** key.

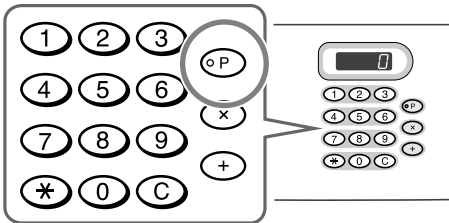

Note:

- Alternatively, from the Master Making Basic Screen, touch **[Functions]** then **[Program]** to display the Program Type screen.

2) Touch **[Combination]**.

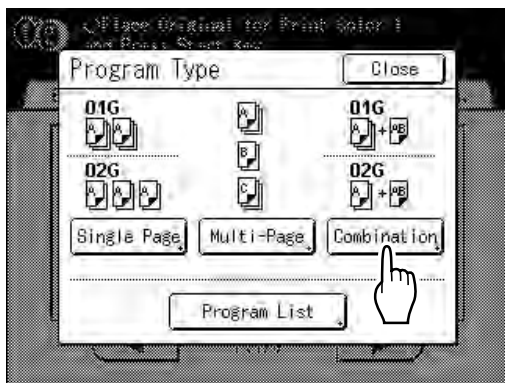

3) Input the number of test copies for each 5 groups into the 5 input boxes (1G to 5G)
Touch the input box and use the Print Quantity Keys to enter a value.

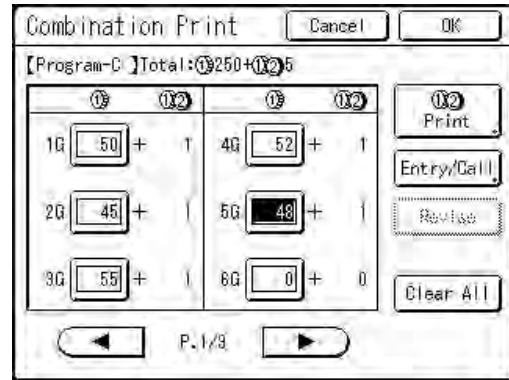

Note:

- The screen above is displayed if a computer is used to send original data. The following steps are performed from the Control Panel.

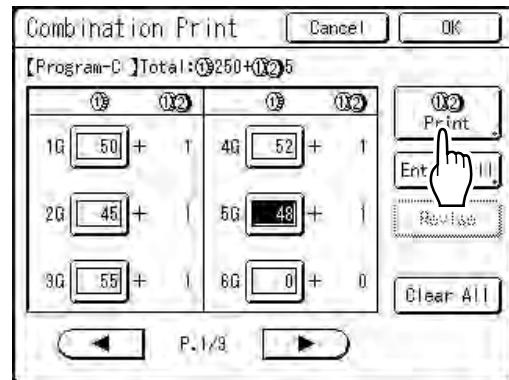

4) Touch **[Print]**.

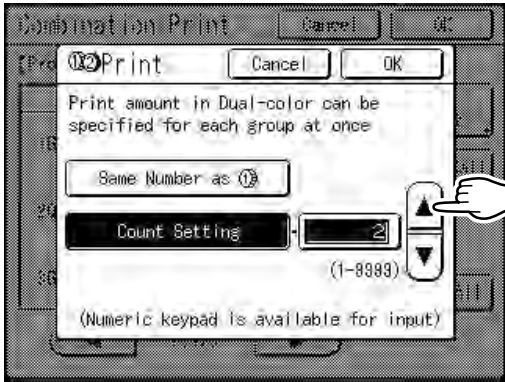

- 5) Touch  and specify "2" (the number of copies for the answer key to each group)



The Print Quantity Keys can also be used to enter a value.

- 6) Touch [OK] and the   Print screen closes. The screen returns to the Combination Print screen.

Note:

- The settings made here are cleared if "Program" is used. If you plan on using the same settings on a regular basis, touch [Entry/Call] to save the settings for later use. See p.139 for details.

- 7) Touch [OK]. Returns to the original screen. Ready to print in accordance with the program.

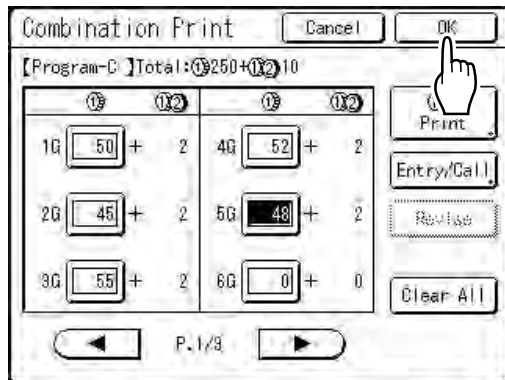

4 Start the printing process.

- 1) Press the  key.

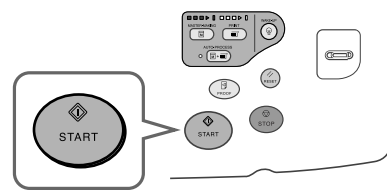

The print job is scanned, separated, and a master created in accordance with "Easy 2Color" settings.

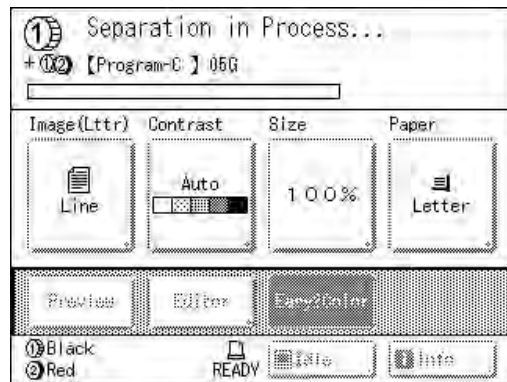
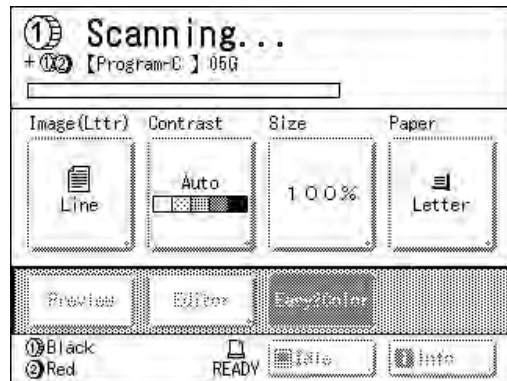



Once the master is made on Cylinder (Drum) 1, one proof copy will be printed from Cylinder (Drum) 1 only. A master will then be made on Cylinder (Drum) 2.



Once the master is made on Cylinder (Drum) 2, a single 2-color proof copy will be printed. After a proof copy has been printed, the Print Basic Screen appears.

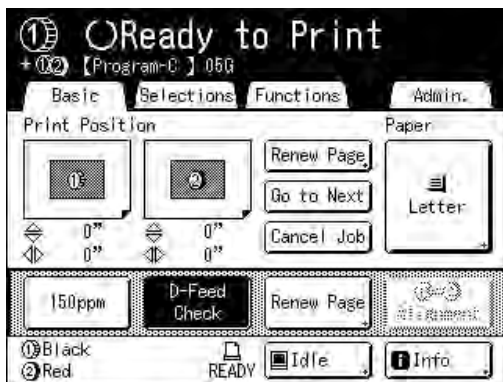

2) Check the proof copy result.
Check the proof copy; e.g., print position and density.
If necessary, change print position and density.

- Print Position (p.115)
- Print Density (p.114)
- Interval Printing (p.120)
- Jump Wing Control (p.122)

3) Press the  key.

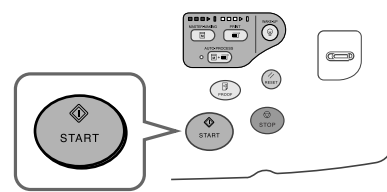

Prints in accordance with "Combination" program settings.

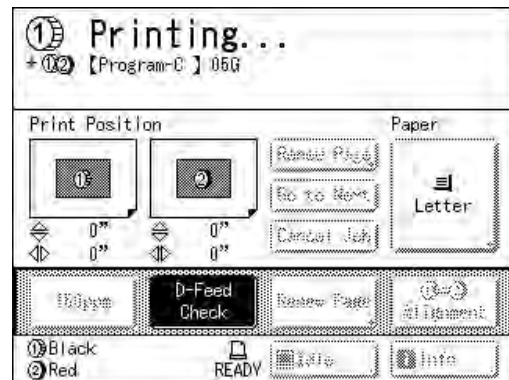

Using Job Memory Functions [Job Memory]

Save the settings of the last print job into Job Memory. Simply retrieve those Job Memory settings when doing a similar print job. Up to 10 jobs can be saved.

The following attributes can be saved to Job Memory.

◆ 2-Color/1-Color Printing (MasterMaking/Print)

Image	Multi-Up Print	Paper Feed Adj.	Auto Page Renewal
Dot Process	Top Margin	D-Feed Check	Air Blow
Contrast	Contrast Adj	Jump Wing Control	Separation Fan
Ink Saving	Tone Curve	Auto Process	
Size	Side Margin	Interval	
Margin+	Print Quantity	ADF Semi-Auto*	
Paper Size	Print Speed	Sorter*	
Max. Scan	Print Density	Job Separation*	
Book Shadow	Print Position	Easy 2Color	

*: Available with optional device

◆ Link Mode (available with Linked Printer)

Image	Feed Tray	Print Quantity	Punch*
Dot Process	Book Shadow	Duplex*	Mailbox*
Contrast	Top Margin	Printer Collate*	Face-up Tray*
Size	Contrast Adj	Offset Pages*	Output Reversal*
Margin+	Tone Curve	Staple*	

*: Available with optional device

Storing Job Memory

- 1 Set various settings for a print job.
- 2 Touch [Functions] on the Master Making Basic Screen.

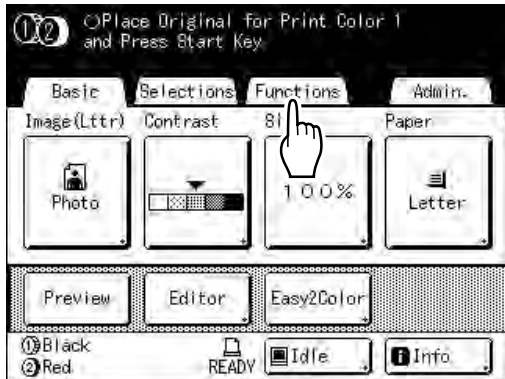

Note:

- Job Memory screen can also be invoked by pressing the ***** key on the Print Quantity Keys. Skip to step 4.

- 3 Touch [Job Memory].



- 4 Touch an unused button.

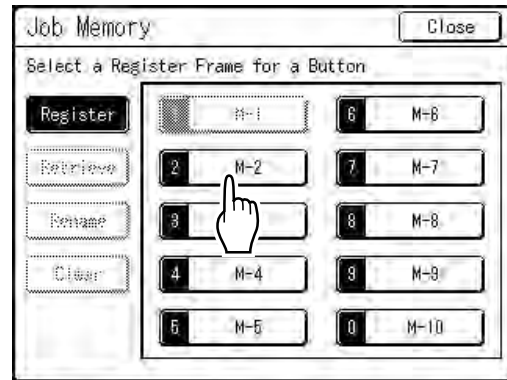

A button in solid lines is available.

Buttons already associated with another job setting are grayed out.

Note:

- If you pressed the ***** key to open the screen, first touch [Register] then select an available button.

- 5 Confirm settings.

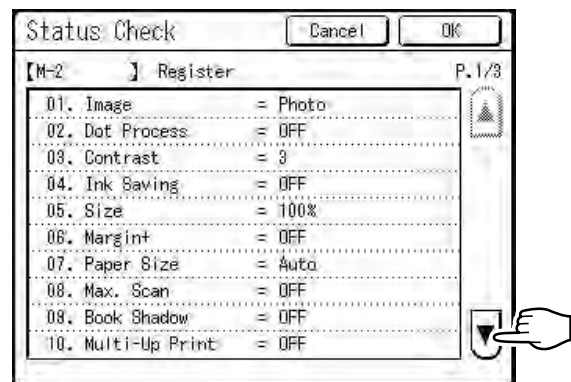

Touch  and scroll down to check all items.

Note:

- To change a setting, touch [Cancel] and start over again. (Return to step 1.)

6 Touch [OK].

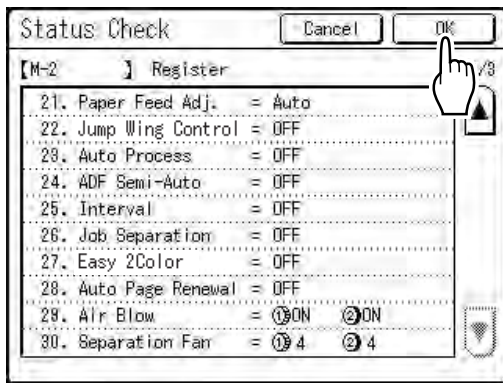

The following screen appears.

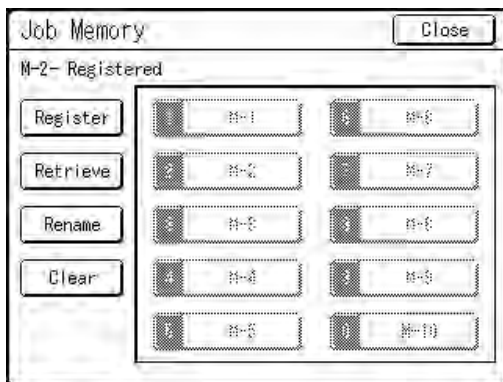

Returns to the Job Memory screen. Settings are updated.

Each job memory can be named for your convenience. See step 3 in “Renaming a Job Memory” (p.153).

Renaming a Job Memory

1 Touch [Functions] on the Master Making Basic Screen.



Note:

- Job Memory screen can also be invoked by pressing the ***** key on the Print Quantity Keys. Skip to step 4.

2 Touch [Job Memory].



3 Touch [Rename].

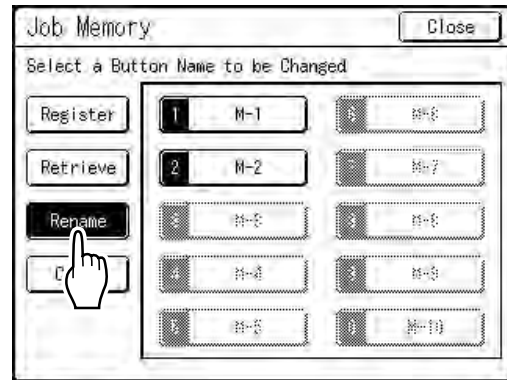

4 Select a Job Memory to rename.

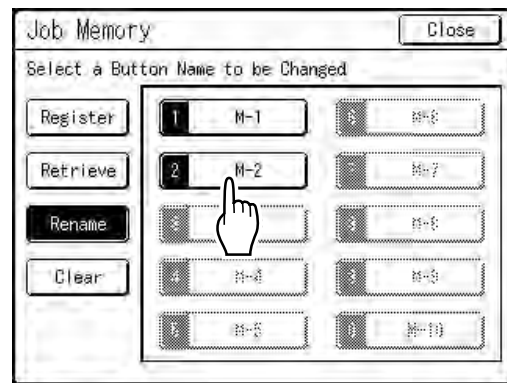

Grayed out buttons are not available (no job memory has been registered yet).

5 Touch **◀C** to delete the current name.

You can also press the **(C)** key to delete.

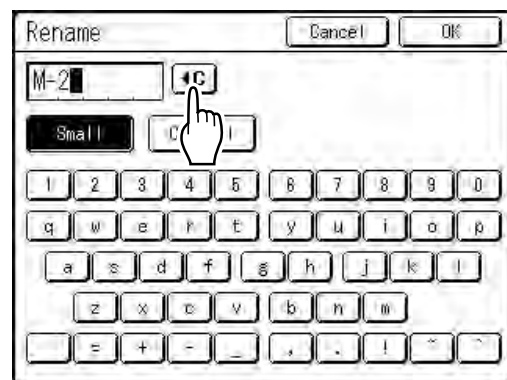

6 Touch character buttons to enter a new name.

Change capitalization by selecting [Small] or [Capital] button.

☞ p.142

7 When entered, touch [OK].

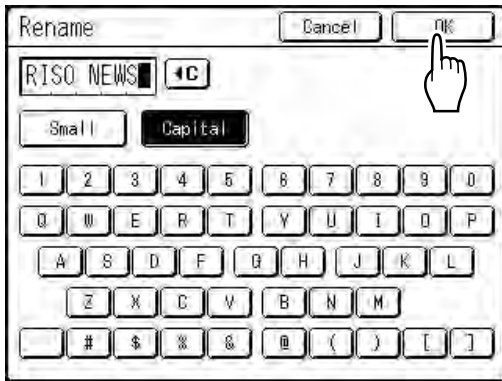

Returns to the Job Memory screen. The name is updated.

8 Touch [Close].

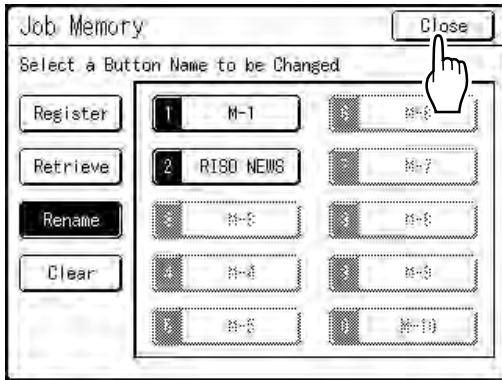

The following screen appears.



Returns to the Functions screen.

Retrieving a Job Memory and Printing

1 Place an original and load paper.

When 2-Color printing with 2 originals [p.40](#)
 When 2-Color printing (Easy 2Color) with 1 original [p.46](#)
 When printing with 1 color [p.58](#)

2 Touch [Functions] on the Master Making Basic Screen.

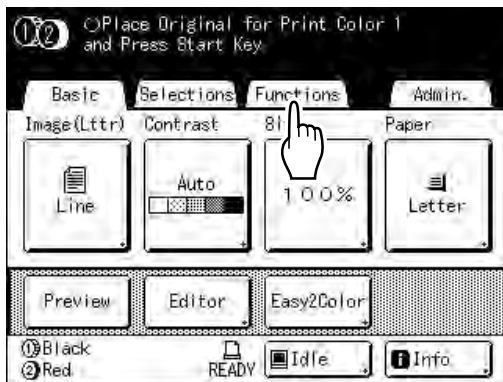

Note:

- Job Memory screen can also be invoked by pressing the ***** key on the Print Quantity Keys. Skip to step 4.

3 Touch [Job Memory].



4 Touch [Retrieve].

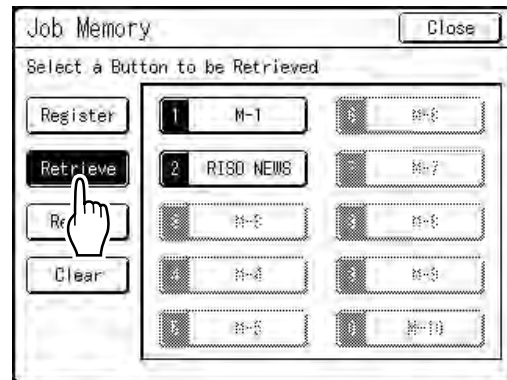

Grayed out buttons are not available (associated with a job setting).

5 Select a Job Memory to retrieve.

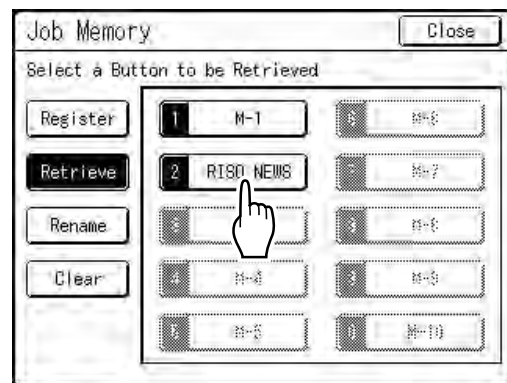

Note:

- A job setting can also be retrieved using the Print Quantity Keys.
 M-1 to 9: **1** to **9**
 M-10: **0**

6 Confirm the settings and touch [OK].

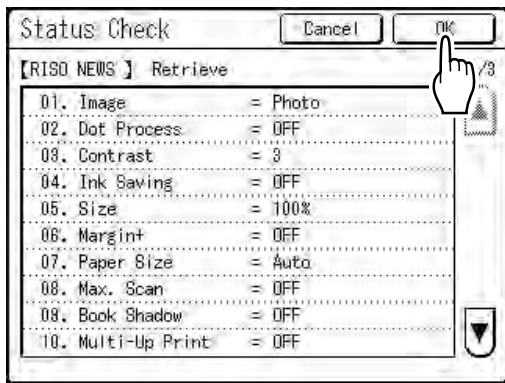

The following screen appears.



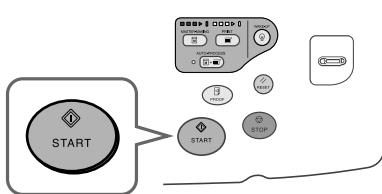

Returns to the Functions screen. Ready to print using the retrieved job settings.

7 Press the key.



The master is made and copies printed in accordance with the Job Memory setting.

Tip: Quick Retrieval

A job setting can be retrieved via hardware keys without touching the Touch Screen. For example, to retrieve and print job M-2, press the , ,  key in that order. M-2 is retrieved and starts the master-making process.

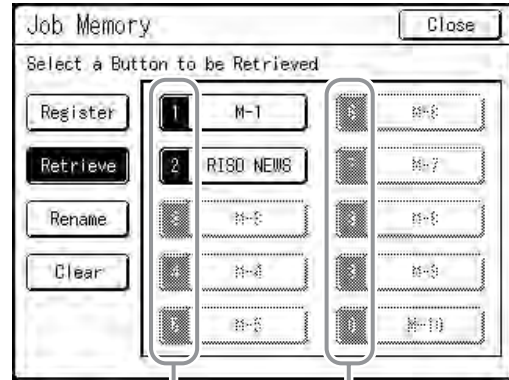

Registered Number

Clearing Job Memory

1 Touch [Functions] on the Master Making Basic Screen.

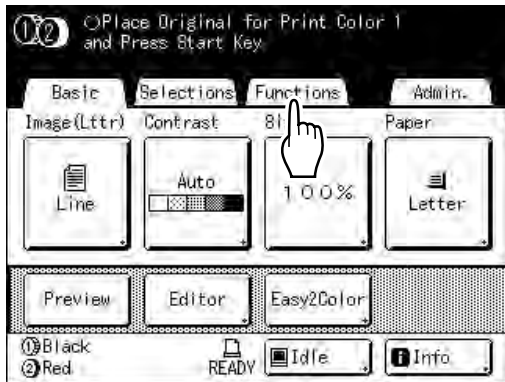

Note:

- Job Memory screen can also be invoked by pressing the key on the Print Quantity Keys. Skip to step 3.

2 Touch [Job Memory].



3 Touch [Clear].

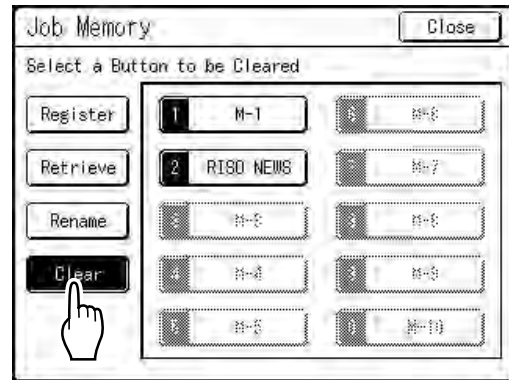

4 Select a Job Memory to delete.

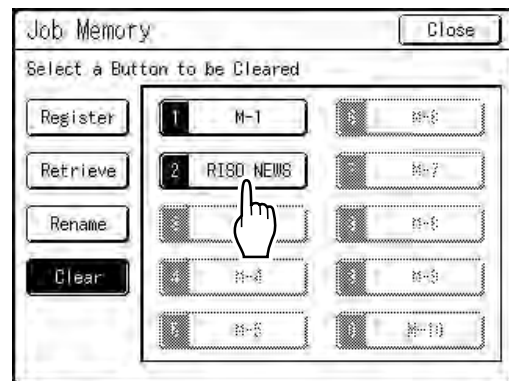

Important!:

- Make sure it is the job setting you want to delete.
- This operation cannot be undone.
- Once deleted, it cannot be restored.

5 Touch [OK].

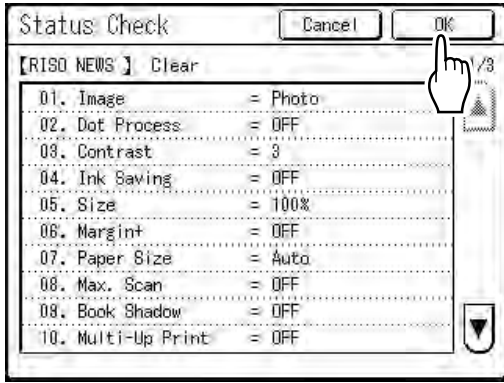

6 Touch [Close].

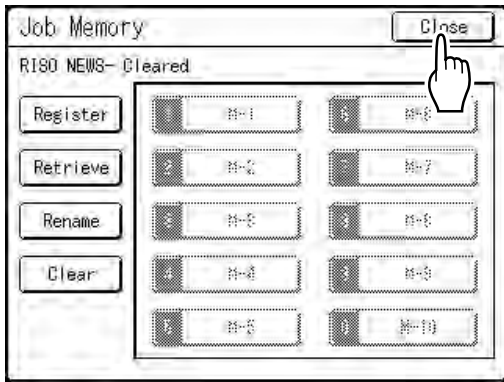

The following screen appears.

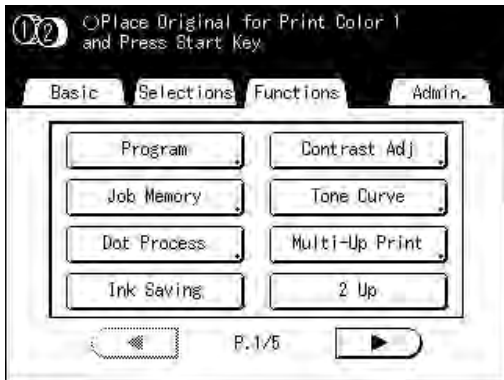

Returns to the Functions screen.

Extending the Reserve Period [Reservation]

This function is useful when the machine is connected to a computer. When the machine is inactive for a certain period of time, it determines that the current job is completed, even if the actual printing is still under way. If another person accidentally initiates another job from the computer, this will cause a new master to be made, discarding the current one.

By extending "Reserve Period", such interruption can be prevented. We recommend that you activate the "Reservation" setting when temporarily pausing a job to prevent interruption.

Note:

- Select from 5, 10, or 30 minutes as the "Reservation" period on the Admin. screen. The factory default is 5 minutes.
 ↪ p.176
- The following operations do not count towards reservation period.
 - When the machine is operating (making a master, printing, confidential action, idling, etc.)
 - When the Job Separator (option) is operating
 - When Control Panel buttons are being entered
- Auto Sleep and Auto Power-OFF will be disabled during the reservation period.
 - Auto Sleep/Auto Power-OFF: timer re-activates after the reservation period is up.
 - Power-OFF Schedule: Will not shut off until next day on time.
 ↪ p.176

1 Touch [Functions] on the Basic Screen.



2 Touch [Reservation].

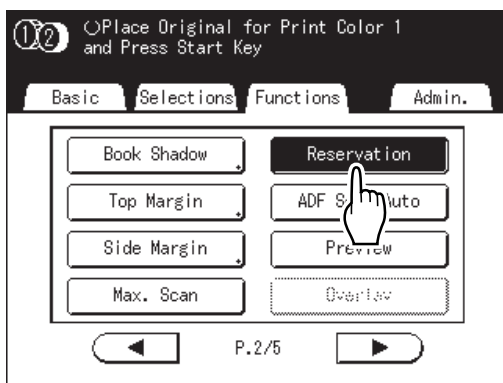

Reservation period is extended.

Idling Action [Idling Action]

When the machine has not been used for an extended period of time, or when the Print Cylinder (Drum) is replaced, the first several copies may be printed too light. By performing “Idling Action” before making a master, high print quality may be instantly achieved and reduce paper waste.

Important!:

- “Idling Action” is effective only in conjunction with the master-making process. When performing print processes only, “Idling Action” will have no effect.

Note:

- If both Cylinder (Drum) 1 and Cylinder (Drum) 2 are set, you can select “Idling Action” for either.
- If you are only using Cylinder (Drum) 1 or Cylinder (Drum) 2, the “Idling Action” is only applied to the cylinder (drum) that is set.
- To perform “Idling Action” automatically when making a master after a specified period of time since the last print job, set “Auto Idling” on the Admin. screen. Idling Rotation can be set from 1 to 3.

☞ p.177

1 Touch [Functions] on the Master Making Basic Screen.



2 Touch [Idling Action].

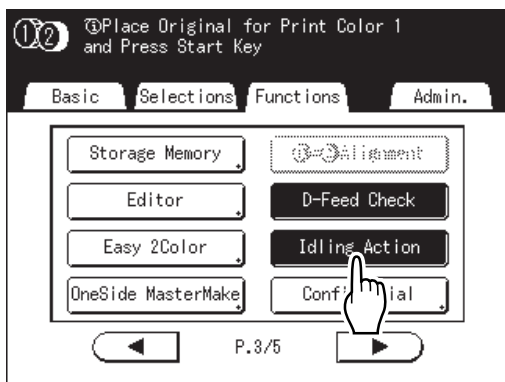

① appears on screen.

3 Press the key.

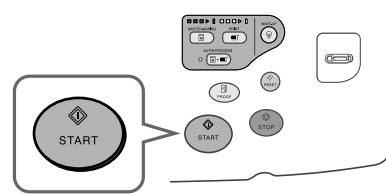

Note:

- Be sure to set the original in place and confirm settings before pressing the  key.

The following screen appears.

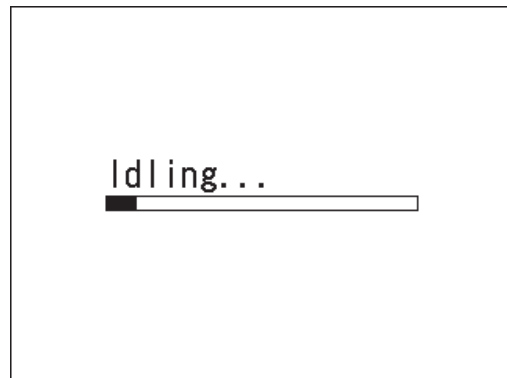

After “Idling Action” has been finished, the master-making process is started.

Note:

- If ① displays in the screen message area, this indicates that the “Auto Idling” time has elapsed. If you make a master in this status, “Idling Action” is executed.



Protecting Confidential Documents

[Confidential]

Master left on the Print Cylinder (Drum) is capable of printing even after the print job is completed. By using the “Confidential” feature, the master on the Print Cylinder (Drum) is discarded, thus preventing unauthorized reproduction of confidential documents such as academic tests or customer lists.

Note:

- When “Confidential” is performed, the discarded master may no longer be reproduced, and “Renew Page” feature is disabled.
- If “Idling Action” is set to “ON”, “Idling Action” is executed using a confidential master (use this function when not using the cylinder (drum) for extended periods of time).

1 Make sure printing is completed.

Confirm that everything is printed.

2 Touch [Functions] on the Print Basic Screen.

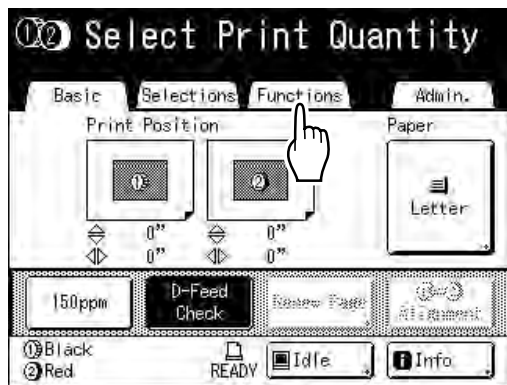

3 Touch [Confidential].

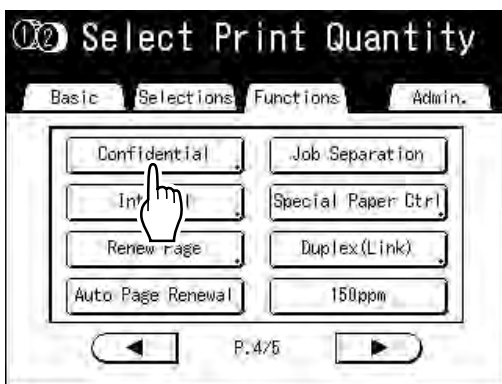

The display screen for 2-Color and 1-Color printing are different.

◆ For 2-Color Printing:

The Drum selection screen appears. Touch the button of the cylinder (drum) whose master you want to discard.

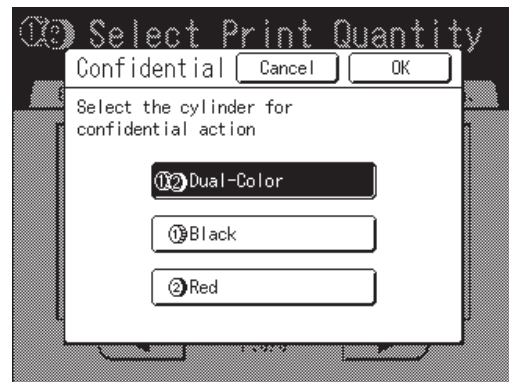

◆ For 1-Color Printing:

The following screen appears.

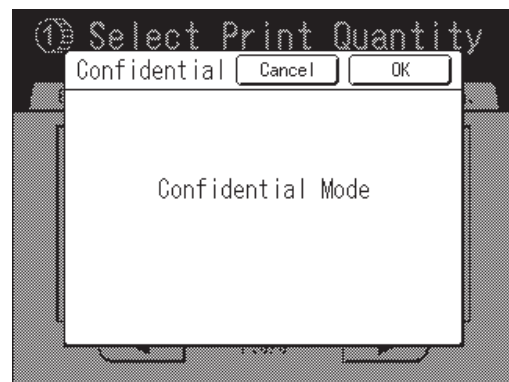

4 Touch [OK].

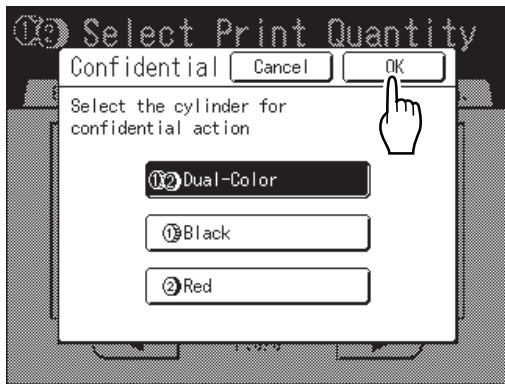

The following screen appears.

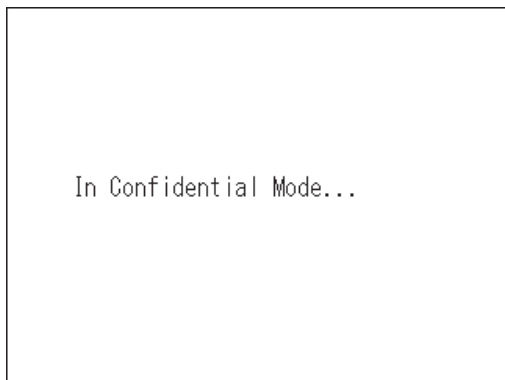

The current master is discarded, and a new master is set on the Print Cylinder (Drum).

Selecting Scanning Sides When Using the Auto Document Feeder DX-1

[Scanning Side -ADF]

When scanning originals using the optional Auto Document Feeder DX-1, there are three scanning side options: “Front Side”, “Back Side”, or “Duplex”.

Important!:

- If the original is set on Auto Document Feeder DX-1, “Book Shadow” function cannot be used.

Note:

- Go to “Admin.” and select “Scanning Side -ADF” to save a frequently used setting as the default.
p.174

◆ **Front Side -> Simplex**

Scans the front side of the original, and prints on one side.

Important!:

- If the “Auto-Link” function is ON or the “Top Margin” function is used, the setting, “Front Side -> Simplex” must be used.
(“Auto-Link” function is not available for MZ990/790U.)

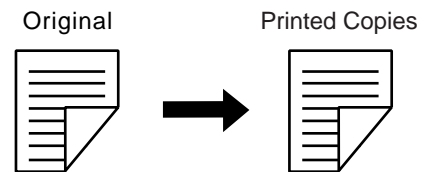

◆ **Back Side -> Simplex**

Scans the back side of the original, and prints on one side.

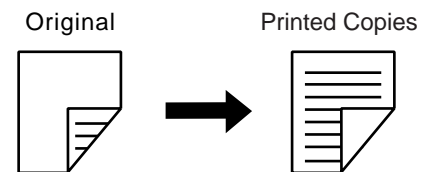

◆ **Duplex -> Simplex**

Scans both sides of the original and prints on one side. The front side is scanned first and then the back side. “Setting Direction” and “Paging Direction” of the original must be specified.

Important!:

- When setting 2-Color Print, “Duplex -> Simplex” cannot be set.(after setting “Duplex -> Simplex”, if 2-Color Print is set, “Front Side -> Simplex” or “Back Side -> Simplex” is restored.)
- The “Duplex -> Simplex” option is not available in “Program; Multi-Page Mode” and “Multi-Up Print”. Likewise, if “Duplex -> Simplex” is selected, “Multi-Page Mode” and “Multi-Up Print” are not available.

Note:

- If the original includes blank pages, these will also be scanned and included in copies.

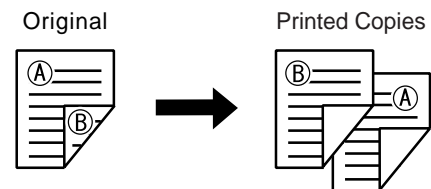

◆ **The processing order of the original and output**

The original set in Auto Document Feeder DX-1 is scanned and printed from the top.

Front Side -> Simplex

- For 1-Color Printing

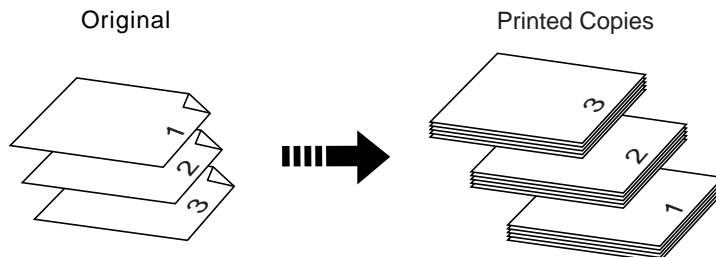

- For 2-Color Printing

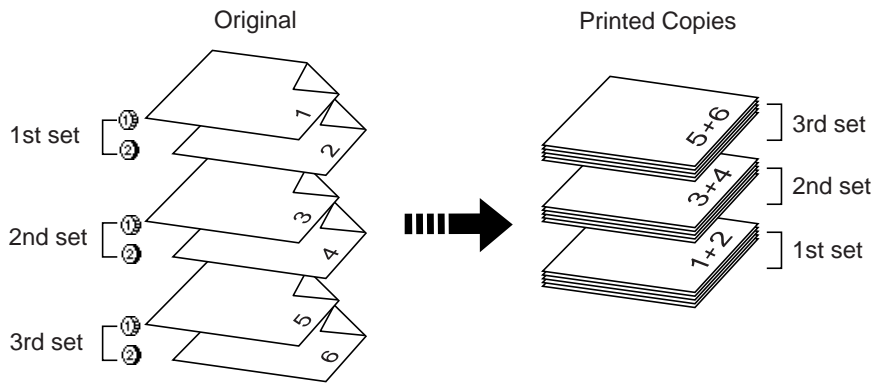

Refers to an original produced with ① for cylinder (drum) 1, and ② for cylinder (drum) 2.

Back Side -> Simplex

- For 1-Color Printing

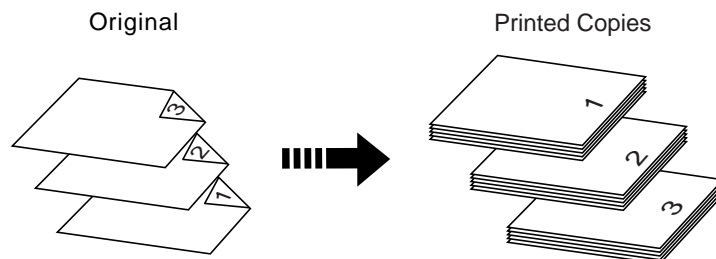

- For 2-Color Printing

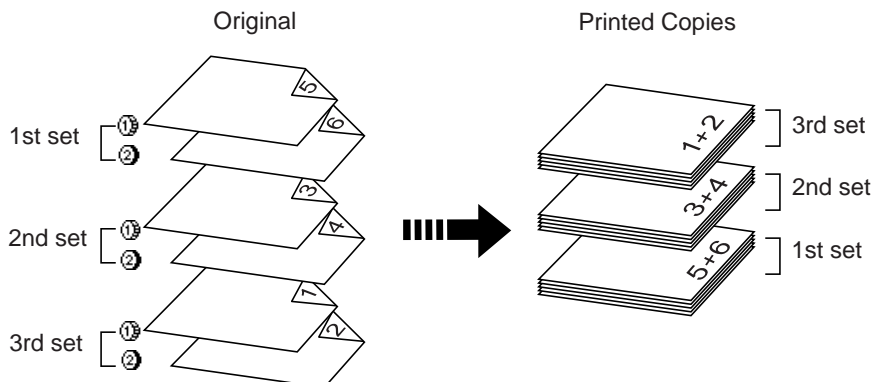

Duplex -> Simplex

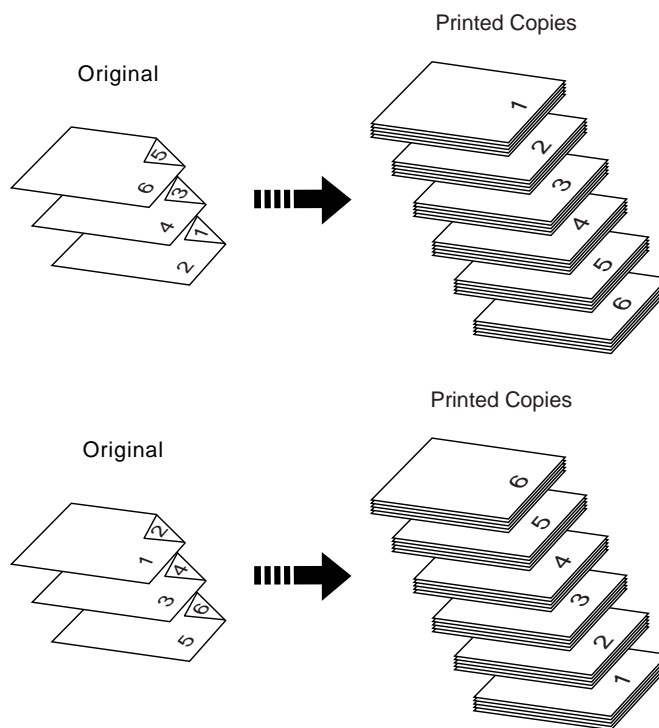

Note:

- In “Program; Multi-Page Mode”, the first page of the original scanned is displayed as “Page01” on the Setup screen.
e.g.
With the “Back Side -> Simplex” option, the last page of the original is displayed as “Page01” on the Setup screen because scanning starts from the last (topmost) page.

Specifying the Scanning Side

1 Touch [Functions] on the Basic Screen for each mode.

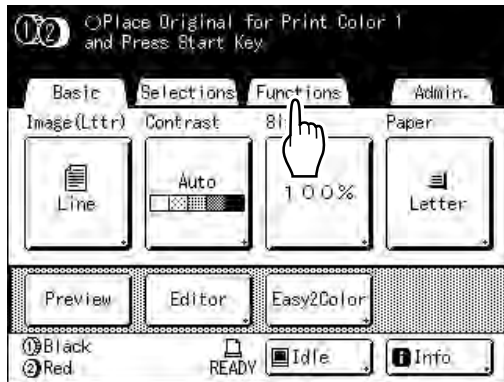

2 Touch [Scanning Side -ADF].

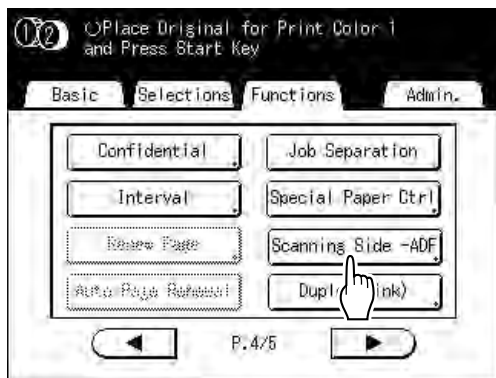

3 Touch a scanning option button.

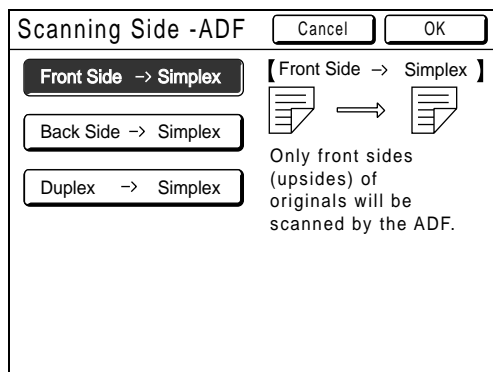

See [p.164](#) for details of scanning options.

◆ When you select [Duplex -> Simplex]

Touch to select [Setting Direction] and [Paging Direction] buttons, shown on the screen.

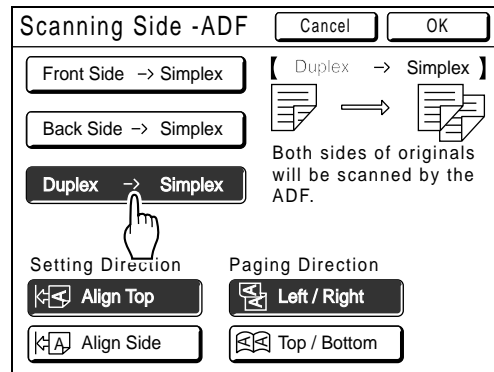

4 Touch [OK].

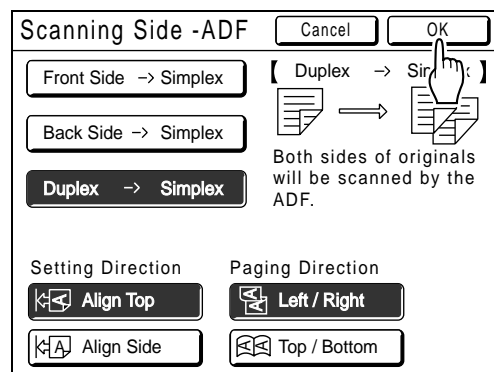

Returns to the basic screen after the “Scanning Side -ADF” settings have been saved.

Note:

- To confirm the current “Scanning Side -ADF” settings, open the “Scanning Side -ADF” screen once more. The selected settings buttons are highlighted.

Tip:
Scanning duplex originals for manual duplex printing

With the optional Auto Document Feeder DX-1, the buttons on the "Scanning Side -ADF" screen can be used to scan both sides of an original and print on both sides of paper.
 e.g.) Scanning the duplex original for duplex printing.

1) Set the original for duplex printing.

◆ **For 1-Color Printing**

← Original orientation

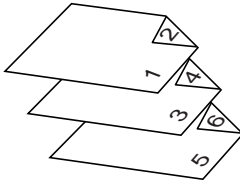

◆ **For 2-Color Printing**

Original orientation

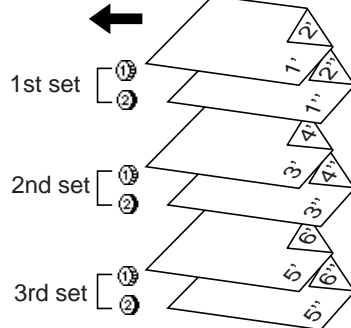

2) Select [Front Side -> Simplex] for printing.

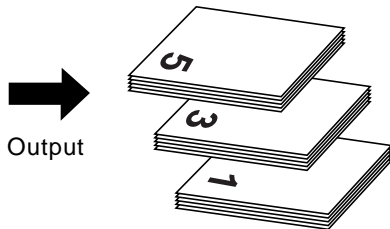

3) Place the printing paper face down in the Standard Feed Tray.

Printing Paper

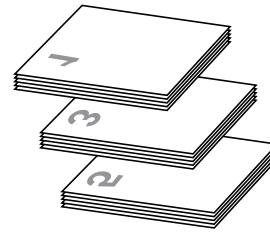

4) Set in the same orientation as shown in step 1.

◆ **For 1-Color Printing**

← Original orientation

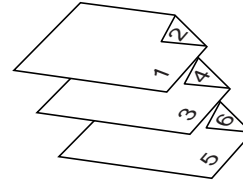

◆ **For 2-Color Printing**

Original orientation

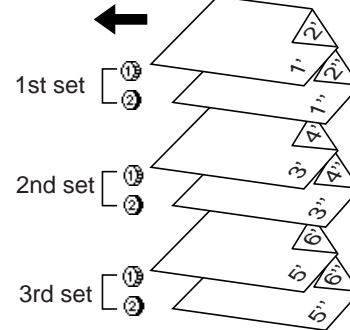

5) Select [Back Side -> Simplex] for printing.

Showing Usage Status [Counter Display]

The machine can record and display the following information:

Copy Count: The total number of copies printed by the machine.

Master Count: The total number of masters made by the machine.

Cylinder1(2): The number of copies printed using the currently installed Print Cylinder (Drum).

Job Count: Start and stop as needed.

For example, to keep track of the number of prints made in a day, set "Job Count" to 0 in the morning, and check the counter at the end of the work day to get the count.

Note:

- When using more than one Print Cylinder (Drum), install the Print Cylinder (Drum) for which you need information before displaying the Counter Display screen.

1 Touch [Functions] on the Master Making Basic Screen.



2 Touch [Counter Display].

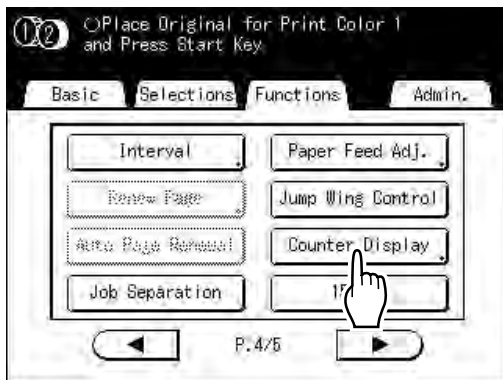

3 Review counts.

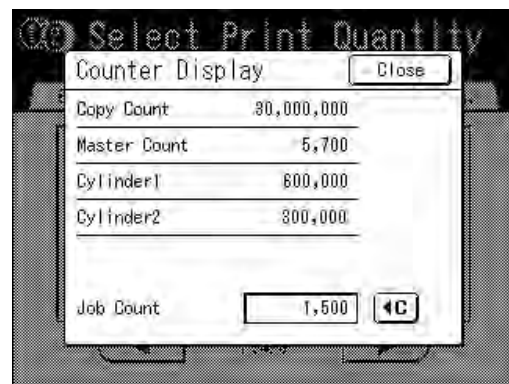

Note:

- Using the "Job Count"
 - 1) Touch to set the counter to 0.
 - 2) Touch [Close] to close the Counter Display screen. Operate the machine as normal.
 - 3) To display and review the Job Count, follow steps 1 and 2.

4 Touch [Close] to close the window.

Returns to the Functions screen.

Rotating the Original 180 Degrees to Make a Master [Rotate]

When you are direct printing, you can rotate the original data received from a computer 180 degrees to make a master.

Important!:

- “Rotate” can also be set from the printer driver, but if it is set on both the machine and printer driver, the job will print without rotating.

1 Touch [Functions] on the Master Make Basic Screen.



2 Touch [Rotate].



Rotate setting is updated.

Proof and Print

(with the Optional ADF unit installed)

[ADF Semi-Auto]

Selecting “Auto Process” with the optional ADF unit installed automatically performs the complete printing job, but you cannot check proof copies, or any necessary adjustments of each master. To pause for check after printing a proof copy of each master, select “ADF Semi-Auto”. After the printing is done, the machine continues to scan and create the next master, then print a proof copy before coming to a stop.

Important!:

- Turn “Auto Process” OFF when using “ADF Semi-Auto”.
☞ p.83

Note:

- The default “ADF Semi-Auto” can be set on the Admin. screen.
☞ p.174

1 Touch [Functions] on the Master Making Basic Screen.

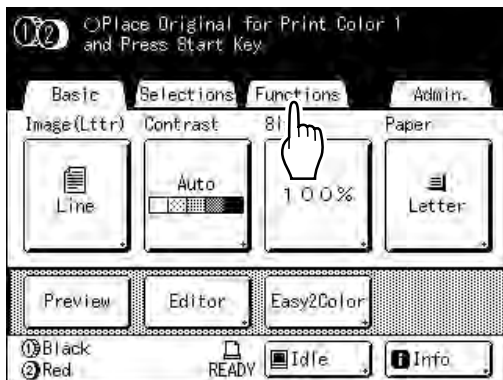

2 Touch [ADF Semi-Auto].

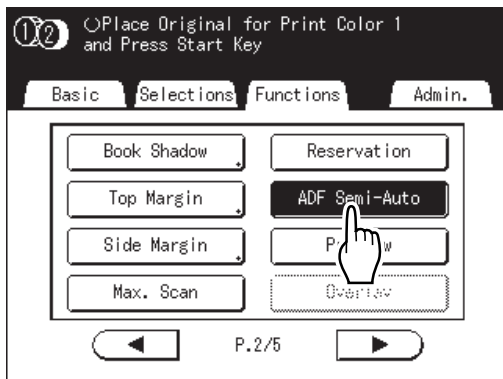

“ADF Semi-Auto” is selected.

3 Place original(s) in the ADF unit.

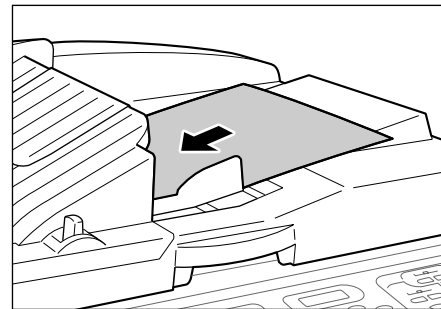

The ADF unit detects the document, and automatically opens the Master Making Basic Screen

4 Enter the number of copies using the Print Quantity Keys.

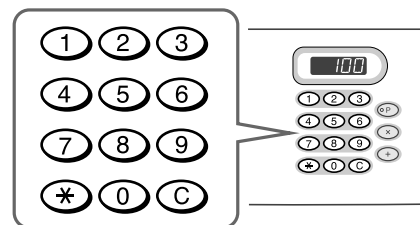

The number is displayed on the Print Quantity Display.

Note:

- To change the number, press the **C** key, then re-enter the correct number.

5 Press the  key.

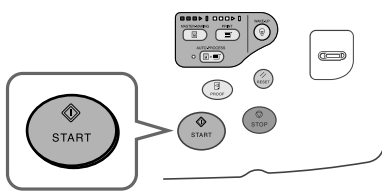

After a master is made, a proof copy is printed and the job stops.

6 Check the proof copy.
Make adjustments if needed.

7 Press the  key.

The machine prints specified number of copies. Master for the next original is made, its proof copy is printed, then the machine stops again.

Repeat steps 6 and 7.

Changing Default Settings [Admin.]

The default settings can be modified to best suit your needs. They may be edited as needed.

Important!:

- Depending upon the usage environment, some of the “Admin.” features may not be available (the “Admin.” tab may not be displayed).
Consult your dealer (or authorized service representative) for details.

Note:







- The default settings are the values restored when the machine is turned ON or when the  key is pressed.

Configurable Functions

==:Initial setting (factory default)

Display Access Button	Functions	Description
[Display]	DirectAccess Entry Store frequently-used functions on the Basic Screen for each mode.	p.182
	Selections Entry Store frequently-used functions on the Selections screen for each mode.	p.182
	Display Priority Select first screen to display following the Startup.	Mode Screen/Dual-Color/1 Color/ 2 Color/ Scanning/Link Mode
	Start-Up Screen Select an animation to display at Start-up.	Logo(RISO)/ <u>Logo(MZ)</u> / Character
	Display Adjustment Change background color, density and brightness of the Touch Screen.	Background:Blue/ <u>White</u> Display Density: -5, -4 ... -1, <u>0</u> , +1 ... +4, +5 Backlight Lightness: -2, -1, <u>0</u> , +1, +2
	Metric/Inch Switch Change the format for displaying measurements to metric or inches (imperial).	<u>inch</u> /mm
	Displayed Language Select the language displayed on the screen. Important!: • Contact your dealer (or authorized service representative) to change the settings.	#01, #02, #03 ...
[Default]	Image Processing Change the default setting for the “image processing mode”.	<u>Line</u> /Photo/Duo (Text and Photo)/Pencil

Display Access Button	Functions	Description
[Default]	Scanning Contrast Change the default setting for the “scanning contrast”.	<ul style="list-style-type: none"> Contrast Range: Lighter/<u>Standard</u>/Darker Contrast: 1, 2, 3, 4, 5, <u>Auto</u>
	Reproduction Size Change the default setting for the “size”.	<u>100%</u> , Auto
	Print Speed Change the default setting for the “print speed”.	1, 2, <u>3</u> , 4, 5
	Print Density Change the default setting for the “print density”.	Print Cylinder 1: 1, 2, <u>3</u> , 4, 5 Print Cylinder 2: 1, 2, <u>3</u> , 4, 5
	Scanning Side -ADF If the machine is equipped with the optional Auto Document Feeder DX-1, select the default scanning side for simplex original using “Scanning Side -ADF”. p.164	<u>Front Side</u> , Back Side
	OP Auto Process Change the default setting for the “Auto Process” when an optional ADF unit or Job Separator is installed.	<u>ON</u> , OFF
	ADF Semi-Auto Change the default setting for the “ADF Semi-Auto” when the ADF unit (option) is installed.	ON, <u>OFF</u>
	Auto Process Mode Change the default setting for the “Auto Process”.	ON, <u>OFF</u>
	Double Feed Check Change the default setting for the “Double Feed Check”.	<u>ON</u> , OFF
	Job Separation Change the default setting for the “Job Separation” when the Job Separator (option) is installed.	ON, <u>OFF</u>
	Jump Wing Control Change the default positioning of the Paper Jumping Wing. Important!: <ul style="list-style-type: none"> This option is available only when the special paper setting is pre-configured. Contact your dealer (or authorized service representative) to pre-configure this setting. 	ON, <u>OFF</u>
	Paper Ejection Adj Change the default settings for “Air Blow” and “Separation Fan”.	Air Blow 1: <u>OFF</u> , ON Air Blow 2: <u>OFF</u> , ON Separation Fan 1: OFF, 1, 2, 3, <u>4</u> Separation Fan 2: OFF, 1, 2, 3, <u>4</u>
	Default Folder Specifies the folder in which to save the data read in scanner mode and the folder to save the data sent from the computer.	Scan Data Folder: 6 folders PC Job Folder: 6 folders

Display Access Button	Functions	Description
[System]	Custom Paper Entry Specify paper dimensions before using non-standard sized paper.	 p.186
	Irregular Fitter Specifies to scan custom-size originals as standard-sized.	MZ990/790: OFF , Ledger, Legal, Letter, LetterR, Statement MZ770: OFF , A3, B4, A4, A4R, B5, B5R, Foolscap
	Folder Renaming Changes the folder name of the folder used to save data.	6 folders
	CI Select Choose between "Internal CI" and "External CI" settings. If the machine is equipped with the optional PS7R, select "External CI".	Internal CI , External CI
	PS7R Information If the machine is equipped with the optional PS7R, set the IP address to connect the machine to the network. IP address settings differ depending on the type of network. Note: <ul style="list-style-type: none"> To change an input source, touch the applicable box, or press the  key to rotate options. If the message "Network Communication is Not Possible" is displayed when touching [PS7R information], touch [Cancel] and wait for the PS7R to finish starting up, then try again. 	<ul style="list-style-type: none"> When using a DHCP server [Use DHCP] When entering IP address manually [Manual Input]   or the Print Quantity Keys.
	Base IP Address Set the IP address for connecting the machine to a network. IP address settings differ depending on the type of network. Note: <ul style="list-style-type: none"> To change an input source, touch the applicable box, or press the  key to rotate options. If the message "Starting Up RISORINC-NET" is displayed when touching [Base IP Address], touch [Cancel] and wait for the RISORINC-NET (Network Card) to finish starting up (approx. 1 minute), then try again. 	
	Stamp Data Registers the stored data as a "Stamp".	 p.210
	Auto 90°Rotation (Only available with MZ990) When setting an original of the same size but with a different orientation from that of the paper loaded in the Feed Trays (Standard Feed Tray, Feed Tray 1 or Feed Tray 2), on the Stage Glass or the optional ADF unit, the 90-degree rotation setting can be used to align original and output documents.	ON , OFF

Display Access Button	Functions	Description
[System]	<p>Margin-Plus Rate Specify default size-reduction rate for the "Margin+" setting.</p>	<p>90 to 99 % (Factory default is 94%)</p>
	<p>Clock/Calendar Set the internal clock of the machine. The time/date displays on the I Info screen. ☞ p.242</p>	<p>Year/Month/Day Hour:Minute</p>
	<p>Scanning Interval When 2-Color printing, sets the time interval to wait for placing the original for Cylinder (Drum) 2.</p>	<p><u>5mn</u>, Limitless</p>
	<p>Reserve Period Select a duration of time (seconds) for the inactive machine to receive data from a computer but restricts processing any output command.</p>	<p>OFF/<u>15s</u>/30s/60s</p>
	<p>Ex. Reserve Period When "Reserve Period" is set, extends the Reserve Period (minutes) to prevent data interruption.</p>	<p><u>5mn</u>/10mn/30mn</p>
	<p>Auto Clear Select whether to reset all settings to default automatically when the machine is inactive for a set period (minutes). After executing "Auto Clear", the "Renew Page" function cannot be used. If you use "Renew Page" frequently, we recommend setting this to "OFF".</p>	<ul style="list-style-type: none"> • Auto Clear OFF/<u>ON</u> • Waiting Time 1-60 mn (factory default is 5 mn)
	<p>Energy Saving Mode Select to activate Sleep Mode or Shutdown Power when the machine is inactive for a set period of time.</p> <ul style="list-style-type: none"> • OFF "Energy Saving Mode" is not activated. Power is turned ON/OFF using the power switch. • Auto Sleep The machine is standing by to receive data from the computer, but the rest of its functions are powered off. • Auto Power-OFF Automatically shuts the power off. (Data cannot be received.) 	<ul style="list-style-type: none"> • Energy Saving Mode OFF/<u>Auto Sleep</u>/Auto Power-OFF • Waiting Time 1-60 mn (factory default is 5 mn)
	<p>Power-OFF Schedule Set a time of the day to automatically shut power to the machine off. If the machine (or its Linked Printers) are in use, or receiving data, power will not shut off.</p>	<ul style="list-style-type: none"> • Power-OFF Schedule <u>OFF</u>/ON • Shut-Off time Hour: Minute
	<p>Protect Determine the "Protect" setting. ☞ p.191</p>	<p><u>OFF</u>/ON</p>

Display Access Button	Functions	Description
[System]	<p>Auto Idling Select whether to perform “Auto Idling” when making a master after a set period of non-use. Also selects a period of non-use before initiating “Auto Idling”, as well as the number of idle rotations.</p>	<ul style="list-style-type: none"> • Auto Idling OFF/<u>ON</u> • Non-Use Time 1-<u>12 hour</u> • Rotation <u>1</u>-3 (times)
	<p>Auto Page Renewal Allows you to set when to recreate a new master. Once the specified number of copies is reached, the master in use is automatically discarded and a new one created. You can also specify the number of proof copies to make after recreating the master.</p>	<ul style="list-style-type: none"> • Auto Page Renewal <u>OFF</u>, ON • Auto Renewal Point 1-9999 copies (Factory default is 1000 copies) • Sample Copy Output 0-99 copies (Factory default is 3 copies)
	<p>Minimum Print Q'ty Set minimum number of copies to print. This prevents master from being made when a smaller quantity is entered for printing.</p> <p>Important!:</p> <ul style="list-style-type: none"> • This setting can be locked to prevent alteration. Consult your dealer (or authorized service representative) for details. 	<p><u>OFF</u>/ON (2-99 copies)</p>
	<p>Stock Management In order to check current stock quantity, insert the number of consumables purchased.</p> <p>Note:</p> <ul style="list-style-type: none"> • When stock quantity falls below the “Remaining Qty to be notified”, a message will appear on the display. • This setting is disabled by factory default. Consult your dealer (or authorized service representative) for details. 	<ul style="list-style-type: none"> • Purchase Qty <u>0</u>-99 Pcs. • Remaining Qty to be notified <u>0</u>-99 Pcs.
	<p>Beep Sound Select whether to activate a beep sound when a key/button is pressed, or when an error occurs.</p> <ul style="list-style-type: none"> • ON Beeps when any key/button is pressed. Beeps when an event is caused/completed. • Limited Does not beep when keys/buttons are pressed. Does not beep when restarting the machine. • OFF Does not beep. 	<p>OFF/Limited/<u>ON</u></p>

Display Access Button	Functions	Description
[Link Mode] Only displayed when a Linked Printer is connected.	Link Properties	☞ p.224
	Linked Printer If only one linked printer (sold separately) is attached to the machine (there are no other linked printers or networked computers), it is “One-to-One”.	PC Network , One-to-One
	Link-Free Volume Set a number of copies by which the output device is determined. When print quantity does not reach the set value, the job is to be output from a Linked Printer. When printing more copies than Link-Free Volume, the machine will perform printing. Note: <ul style="list-style-type: none"> This function is not available for MZ990/790U. The default value is 20 copies. “Minimum Print Q'ty” cannot be set when “Link-Free Volume” is ON. 	ON [Link-Free Volume] 2-99 copies/OFF (Factory default is 20 copies)
	Duplex Interval Select the interval time (seconds) between first and second scans when using Double-sided Printing.	<u>15 seconds</u> /30 seconds
	Online Auto-Link Select whether to automatically output a job from the Linked Printer when print quantity is less than Link-Free Volume. Note: <ul style="list-style-type: none"> This function is not available for MZ990/790U. When “Link-Free Volume” is OFF, this item is grayed out and not available. 	<u>ON</u> , OFF
	Color Auto-Link If another cylinder (drum) besides the black one is set when printing with 1-color, set “Link-Free Volume” to specify whether or not to print with the currently set cylinder (drum) color. Note: <ul style="list-style-type: none"> This function is not available for MZ990/790U. 	<u>ON</u> , OFF
	Link Info Refresh Set how frequently the machine receives data from a Linked Printer.	10-999 seconds (Factory Default is 15 seconds)
[Editor]	Print Colors	See the RISO Editor User's Guide for details.
	Tool Bar Position	
	Sub Tool Bar	
	Page Orientation	

Customizing the Default Settings

The default settings can be changed when the machine is not in operation. Make sure there is no pending or current Print Job operation.

Note:

- On the Admin. screen, the current setting is displayed on the right side of each button.

1 Touch [Admin.] on the Basic Screen for each mode.

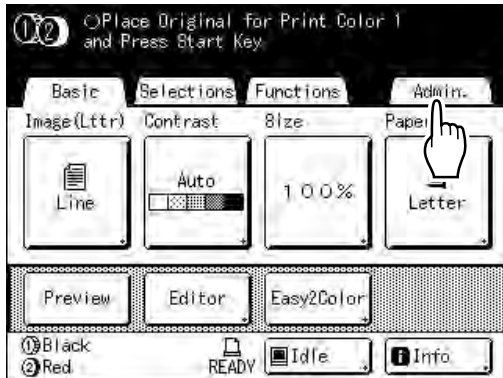

2 Touch [OK].



3 Select a function to modify.

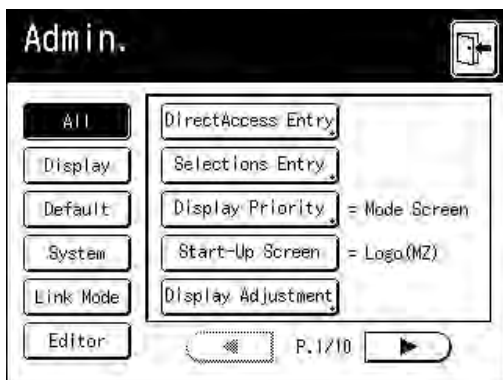

Display Access Buttons

Display Access Buttons allow for quick selection of desired functions by displaying only relevant groups of function buttons.

[All]: All Functions

[Display]: Functions related to Screen Display

[Default]: Basic Operational Functions

[System]: Functions affecting the entire System

[Link Mode]: Functions related to Linked Printer

[Editor]: Functions related to Editor

- **[Link Mode]** is only displayed when a Linked Printer (sold separately) is connected.

4 Change settings.

Some functions have their own Setup screens, some don't. There are several styles for setting values. Following samples demonstrate different value setting styles.

◆ No additional Setup Screen

(2 or more options to choose from)

Touch the function name button to change the value displayed to the right.

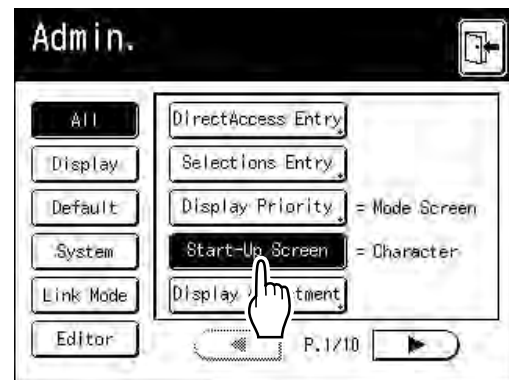

Once the settings have been changed, continue on to step 6.

◆ **Additional Setup Screen Available**

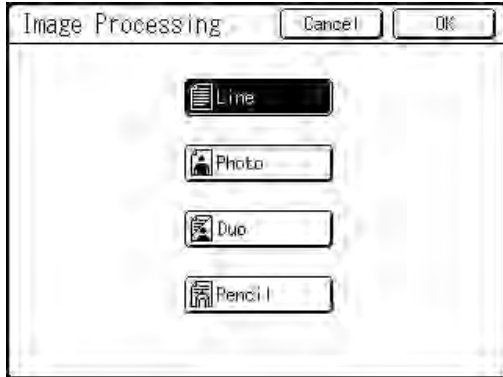

Button Style

Choosing a button makes it the default.



◆ **Additional Setup Screen Available**

Numeric Value Style

Touch   to increase/decrease value. Numbers may be entered using the Print Quantity Keys.

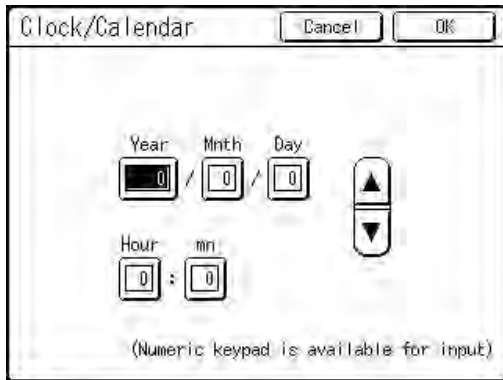

◆ **Additional Setup Screen Available**

Multi Level Entry Style

Select a button, then set its values either by touching more buttons or entering a value numerically. Touch **[ON]** to display more options on the right.

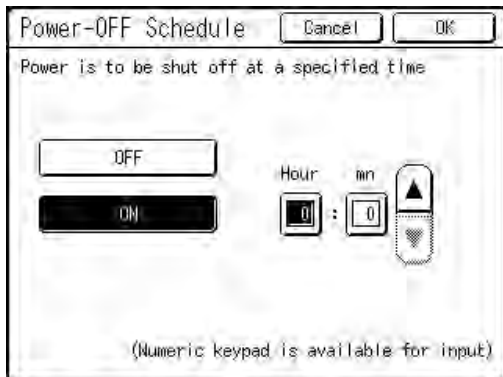

◆ **Additional Setup Screen Available**

Text Input Type

Input the name after touching the button of the name to change. Touch the button and the Rename screen appears.

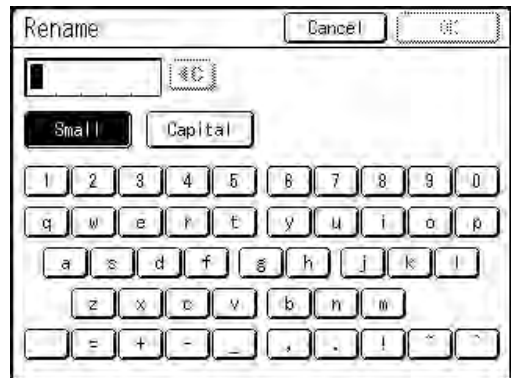
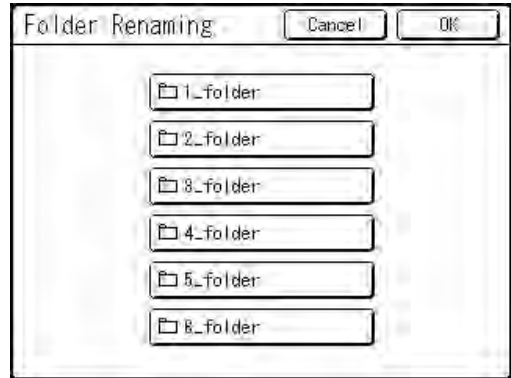

Touch the character buttons to enter text. Change capitalization by selecting **[Small]** or **[Capital]** button.

☞ p.142

◆ Additional Setup Screen Available

Data Specification Type

A screen to specify the stored data displays.
See p.204 for details on specifying the data.

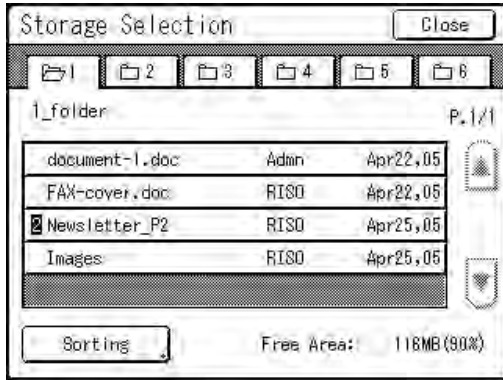

5 Touch [OK].

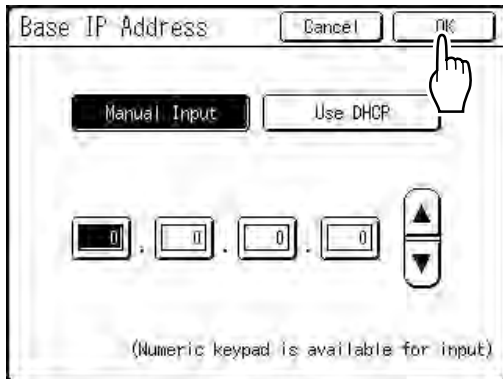

Skip to step 6 if there is no additional setup screen.

Note:

- Touch **[Cancel]** to cancel the changes and return to the Admin. screen.
- The selected value is displayed to the right of the button (for most functions).

6 Touch .

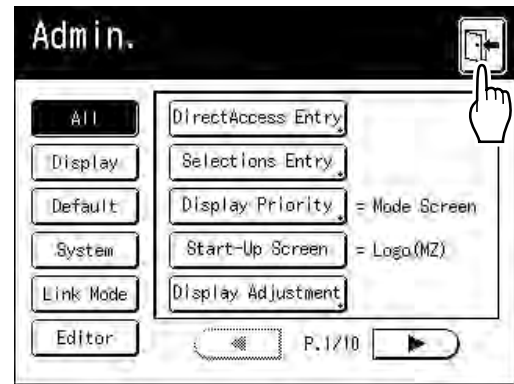

Returns to the original Basic Screen.

Setting Up Direct Access Area and Selections Tab

[DirectAccess Entry] [Selections Entry]

Frequently-accessed functions for each mode can be placed on “Direct Access” area in the Basic Screen, or on “Selections” screen.

This allows quick changes and direct access to each function's Setup screens, eliminating the need to search from a long list of functions.

Each mode (Master Making/Print/Scanning/Link) is capable of storing its own unique settings. “Direct Access” area can store up to 4 items, “Selections” screen can store up to 9 items (6 in the Link Mode, no item in the Scan Mode).



Direct Access Area

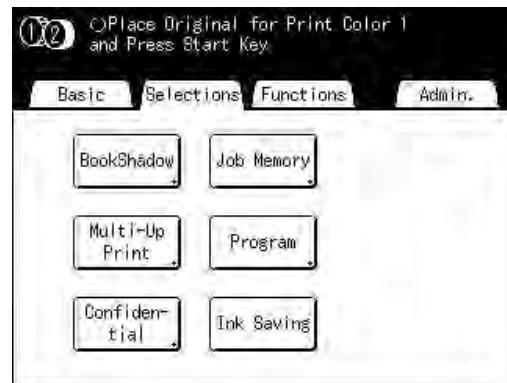

Selections Screen

Note:

- Choose functions that are relevant to each mode.
- The machine comes with factory default “Direct Access” area and “Selections” screen entries, which can be changed.
- Any functions available in the “Functions” screen can be selected.
- When there are multiple Linked Printers, select a device first, then make changes in the “Admin.” tab to select/modify “Direct Access” area and “Selections” screen.
- Optional attachment is automatically added to the “Direct Access” area and “Selections” tab if a space is available for another button.
(Optional devices to a Linked Printer must be entered on the Admin. screen.)

In the following steps, the “Direct Access” area configuration screen is shown in the upper-left, and the “Selections” configuration screen is shown in the bottom-right. When both screens are the same, only one image will be shown.

- 1 Touch [Admin.] on the Basic Screen for each mode.

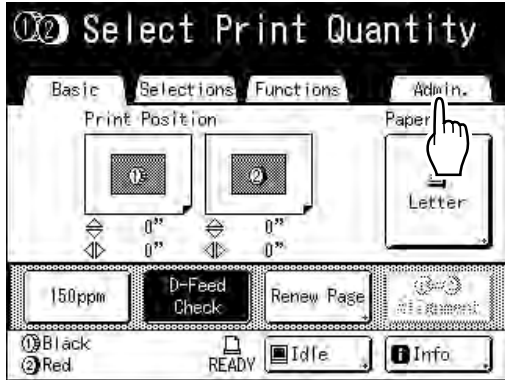

- 2 Touch [OK].

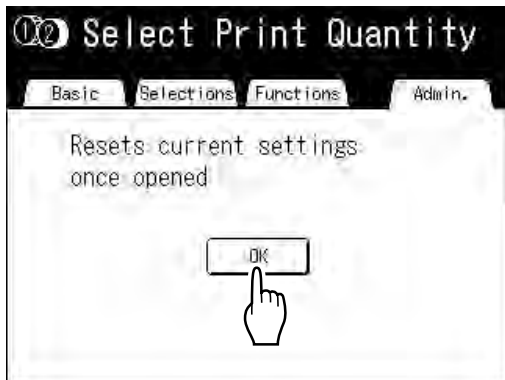

- 3 Touch [DirectAccess Entry] or [Selections Entry] on the Admin. screen.

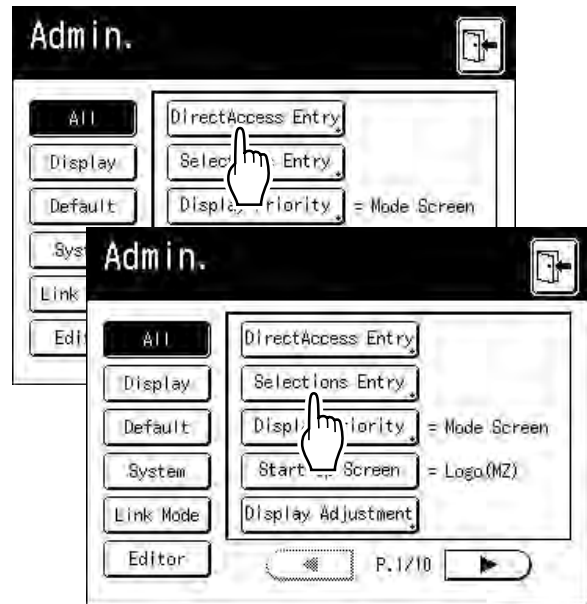

- 4 Select a mode tab to store new buttons.

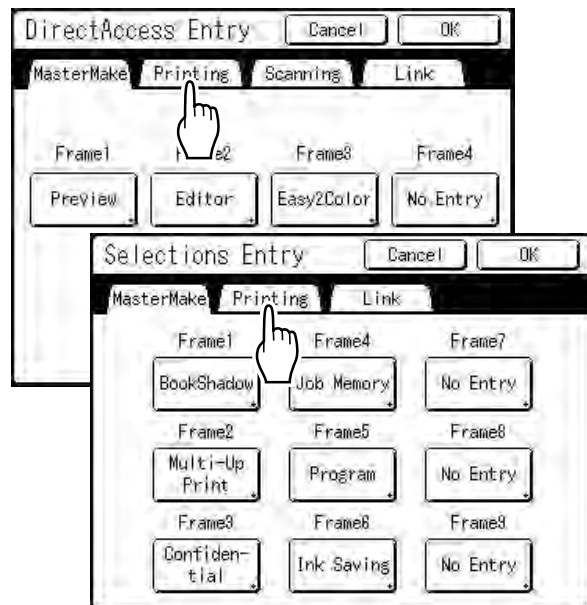

5 Select a button to assign a function.

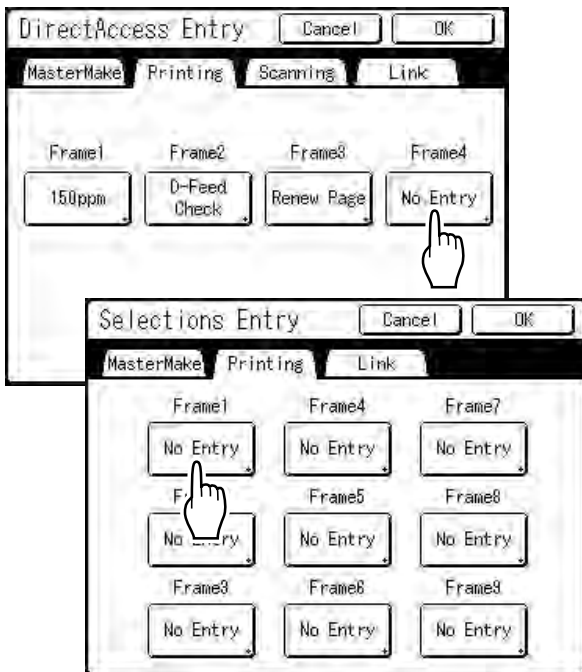

Note:

- If the button has a function already assigned, the newly selected function will overwrite.

6 Select a function to assign.

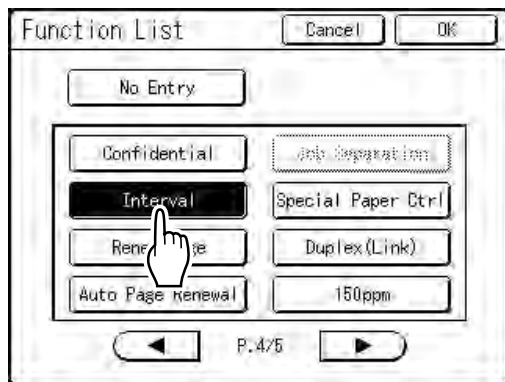

Note:

- Touch ◀ or ▶ to display more functions if necessary.
- To remove a function accidentally assigned, touch **[No Entry]**.
- Functions already assigned are grayed out and not available for selection.
- Some functions display only when optional devices are installed.

7 Touch [OK].

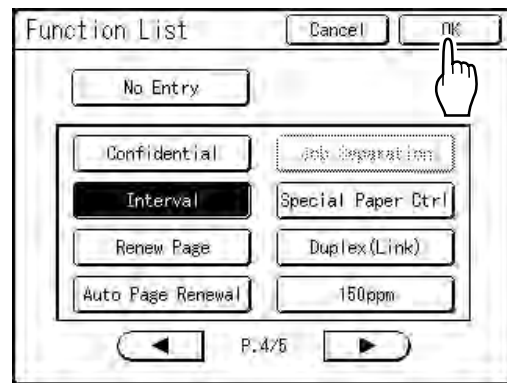

Returns to “Direct Access” area or “Selections” screen. Selected functions are added. To add more functions, or to replace a button with another function, repeat steps 4 and 5.

8 Touch [OK].

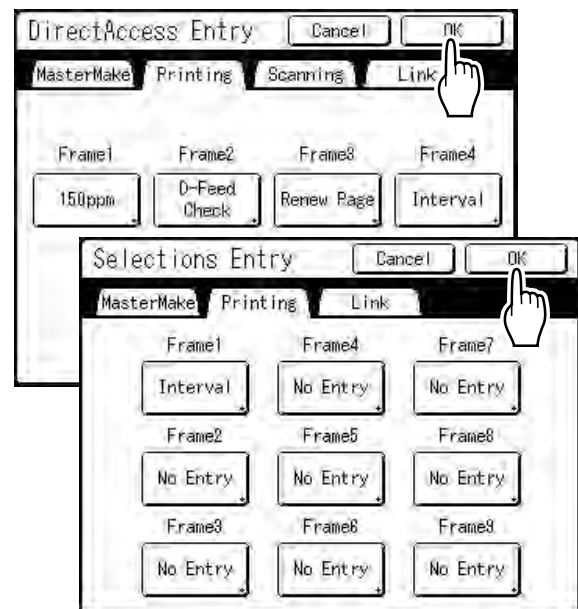

Returns to the Admin. screen. “Direct Access” area or “Selections” screen is updated.

9 Touch

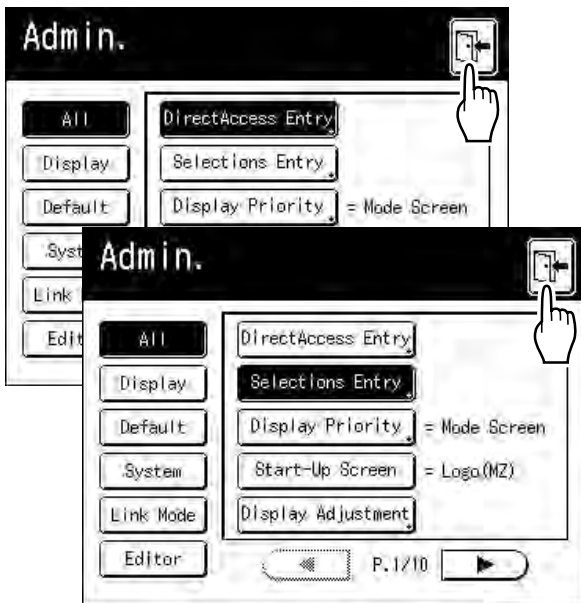

Returns to the Original Basic Screen.

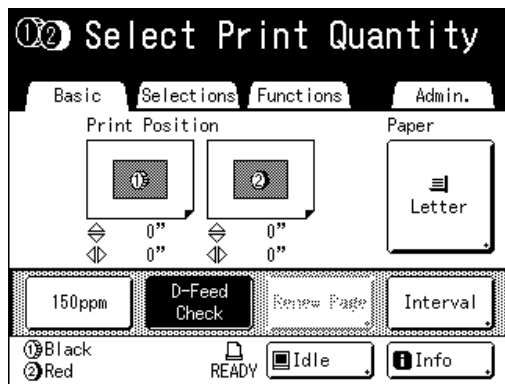

Registering a Custom Paper Size

[Custom Paper Entry]

Non-standard paper sizes must be pre-entered into memory. Once a paper size is stored into memory, it can be retrieved with the **[Paper]** button from the Master Making Basic Screen.

Up to 30 different sizes may be entered. Previously stored sizes can be modified or deleted.

You can register paper sizes between 3.9" × 5.8" (100 mm × 148 mm) to 13.4" × 21.9" (340 mm × 555 mm). However, any paper longer than 17.2" (436 mm) prints in extended paper mode.

☞ p.188

Important!:

- Custom paper sizes must be entered. Failure to do so may result in incorrect scanning.
- 2-Color printing is not possible for paper lengths of 9.6" (246 mm) or less.

Entering sizes and changing names

- 1 Touch **[Admin.]** on the Basic Screen for each mode.



- 2 Touch **[OK]**.



- 3 Touch **[System]** or **[▶]** to display **[Custom Paper Entry]** on the screen.

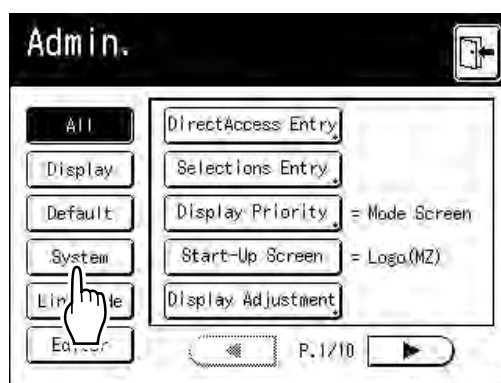

- 4 Touch **[Custom Paper Entry]**.

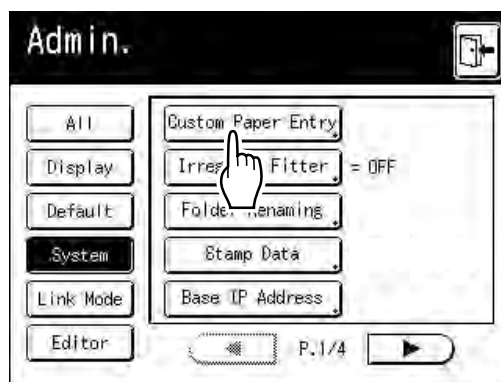

5 Touch an unused button.

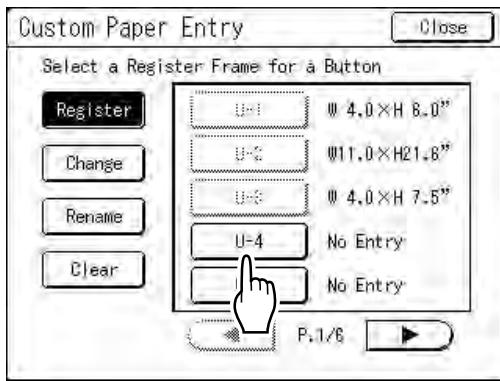

A button already associated with another size is grayed out.

6 Enter the paper size.

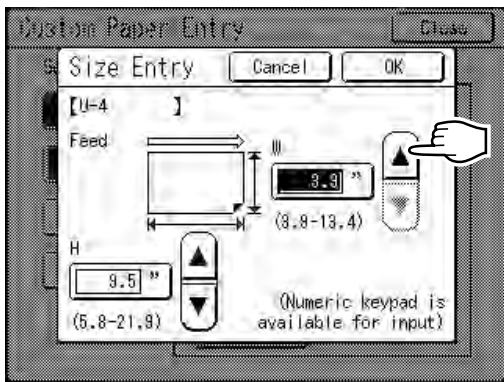

Facing towards the paper feeding direction (into Paper Feed Tray), enter W (width) and H (height). Touch either , or use Print Quantity Keys.

7 Touch [OK].

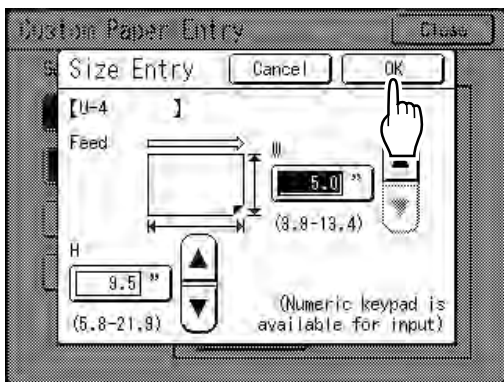

Rename as necessary.
Touch **[Close]** to skip renaming the size.

8 Touch [Rename].

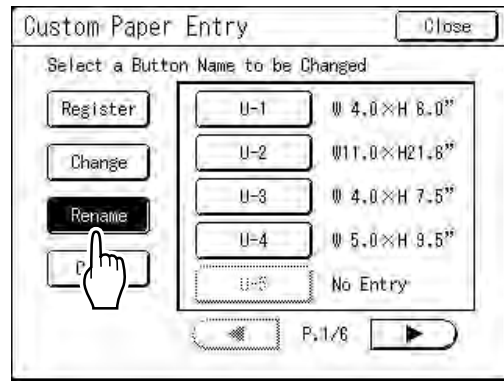

9 Select a button to rename.

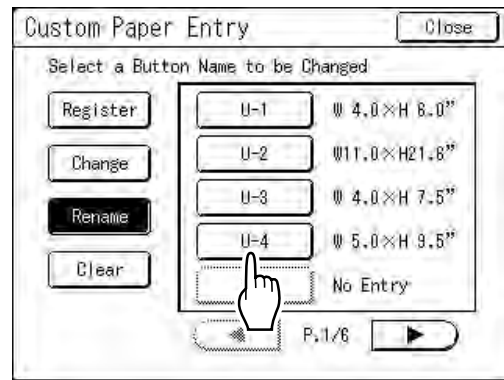

10 Touch C to delete the current name.

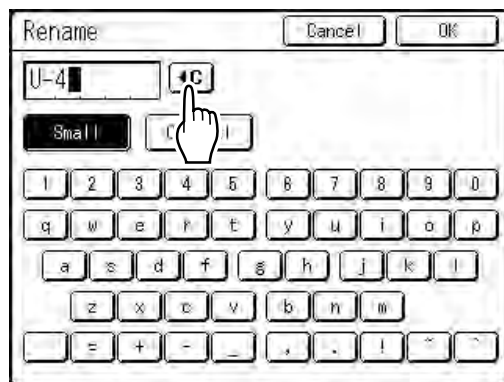

11 Touch character buttons to enter a new name.

Change capitalization by selecting **[Small]** or **[Capital]** button.
[p.142](#)

12 Touch [OK] when done.

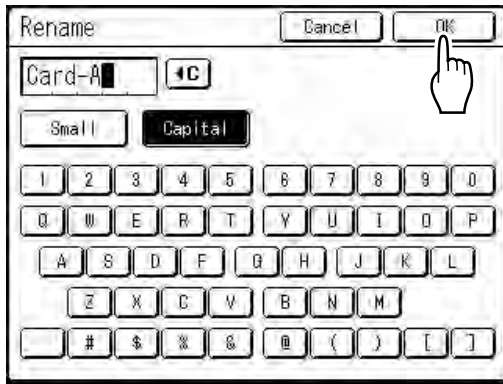

Note:

- To change a name, repeat from step 8.

13 Confirm the name and touch [Close].

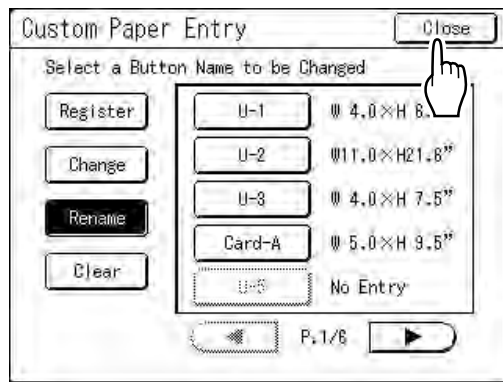

The following screen appears.

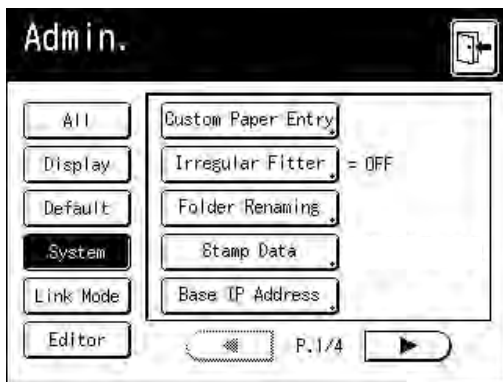

Returns to the Admin. screen. Paper size is updated.

Tip:

Printing on Extended Paper

The machine can print on paper 17.2"-21.9" (436 mm-555 mm) long (top to bottom facing the paper feeding direction) by storing the size as a custom-size.

When entering a size longer than 17.2" (436 mm) (top to bottom facing the paper feed direction) on the Custom Paper Entry screen, the paper will be treated as "Extended Paper".

When "Extended Paper" is selected on the Custom Paper Entry screen, the machine switches into "Extended Paper" mode.

Important!:

- Some Extended Paper may fail to pass through the machine due to its paper characteristics, or may get smudged with ink due to its image positioning. Consult your dealer (or authorized service representative) for advice.

"Extended Paper" Mode

- When the machine is on "Extended Paper" mode, it is indicated in the message area as either "Ready to Make Master <Ext.Paper>" or "Ready to Print <Ext.Paper>".
- On "Extended Paper" mode, the machine can print papers measuring 17.2"-21.9" (436 mm-555 mm) lengthwise from top to bottom facing the paper feed direction. However, maximum printing area and top/bottom Print Positioning range remains as usual.
 - ☞ p.17
 - ☞ p.115
- Print timing and speed is different on "Extended Paper" mode in comparison to normal printing. This is to be expected, so do not be alarmed.
- Contact your dealer (or authorized service representative) for suggestions about placing paper on the Paper Receiving Trays when on "Extended Paper" mode.

Deleting a Custom Paper Size

- 1 Touch [Custom Paper Entry] on the Admin. screen.

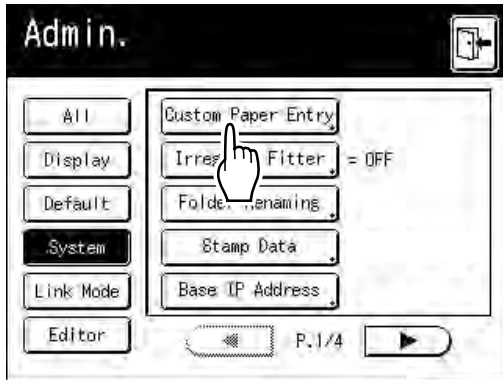

- 2 Touch [Clear].

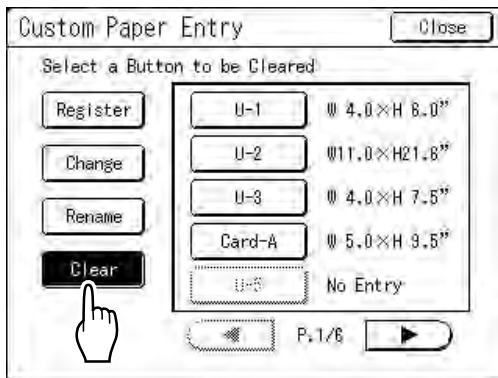

- 3 Select the paper size to delete.

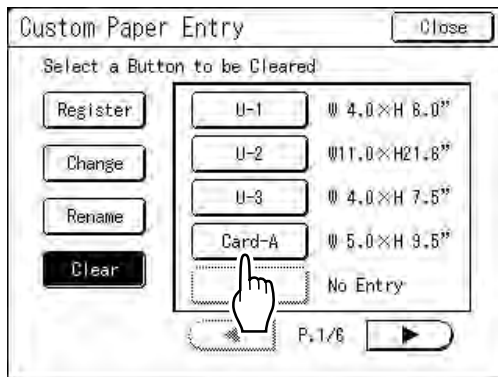

- 4 Touch [OK].

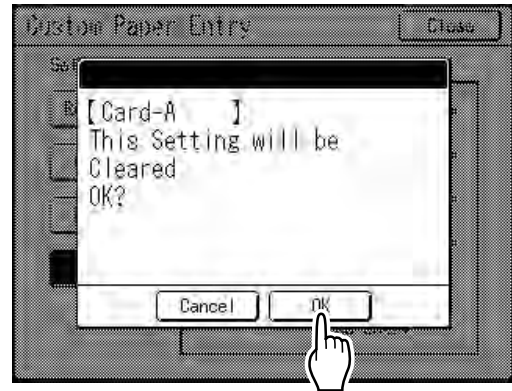

Returns to the Custom Paper Entry screen. The selected paper size is deleted.

- 5 Touch [Close].

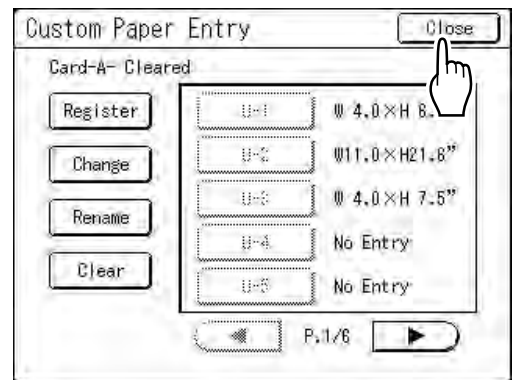

The following screen appears.

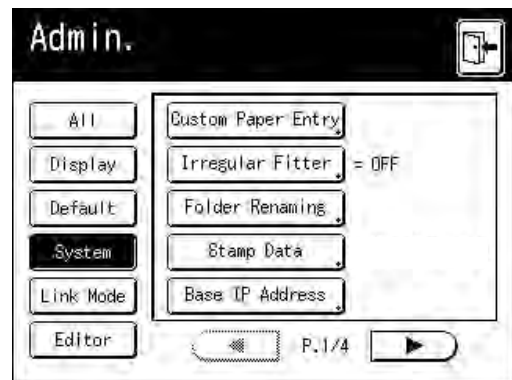

Returns to the Admin. screen. Paper size is updated.

Keeping Masters Secure After Printing

After printing is completed, the master remains on the Print Cylinder (Drum). To protect confidential documents from unauthorized duplication, use the Confidential feature to discard the master after printing. (i.e. “Confidential” function) Used masters are held in the Master Disposal Box. The machine is equipped with a protection function to prevent the master from being removed from the Master Disposal Box and leaked by any ill-intended third party.

“Protect” Setting

When the “Protect” setting is ON:

- When printing is complete, the “Confidential” function is activated to show the message to discard the master remaining on the Print Cylinder (Drum).
- The Master Disposal Box is locked and cannot be removed while the machine is standby. (However, the Master Disposal Box can be unlocked and removed if the master is jammed in the Disposal Unit or the Master Disposal Box is full.)

Locking the Master Disposal Box

To prevent any leak of master documents after printing, the Master Disposal Box can be locked with a padlock so that no-one apart from the administrator of the machine can remove it. (Purchase an ordinary padlock whose loop will fit through the hole, which is $\frac{9}{32}$ ” (7 mm) wide.)

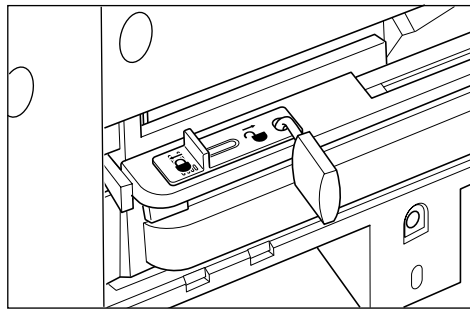

Status of Protect functions and restrictions

Status of [Protect] functions	Restrictions
Protect: OFF Padlock: No	No restrictions on printer access ^{*1}
Protect: ON Padlock: No	“Confidential” message is displayed Master Disposal Box is locked ^{*2}
Protect: OFF Padlock: Locked	No “Confidential” message is displayed Nobody but the administrator can dispose of the master.
Protect: ON Padlock: Locked	“Confidential” message is displayed Nobody but the administrator can dispose of the master.

*1 The ordinary “Confidential” function is available.

*2 Disposal Unit errors may cause the lock to be released.

Preventing Leaks of Masters After Creation or Disposal [Protect]

Turning the Protect Setting ON

1 Touch [Admin.] on the Basic Screen for each mode.

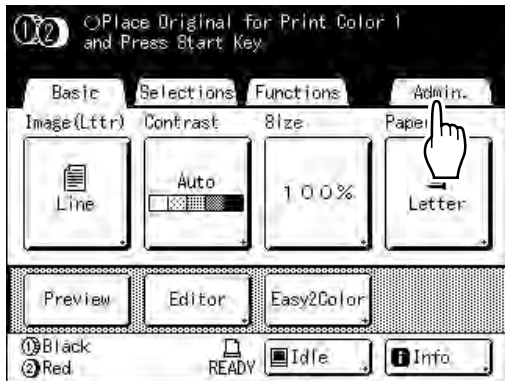

2 Touch [OK].



3 Touch [Protect].

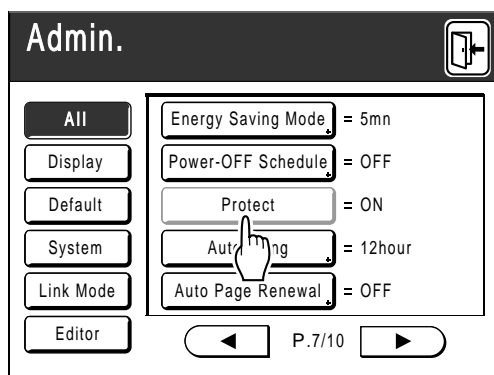

"Protect" is turned ON and the button is grayed-out.

Note:

- If "Protect" is ON, "Energy Saving Mode" (Auto Sleep) is activated automatically.
- If "Protect" is ON, **[Renew Page]** is grayed-out with no access allowed.

◆ If "Protect" is ON:

The following screen is displayed after printing.

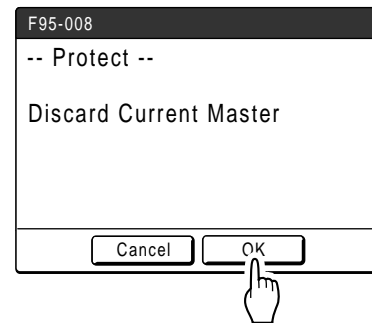



Touch **[OK]** or **[Cancel]**.

[OK]: Discards the master remaining on the Print Cylinder (Drum).

[Cancel]: Choose this when you do not wish to discard the master or wish to print further copies.

Note:

- The "-- Protect -- Discard Current Master" message is also displayed when printing from computer data on a PC.
- If you select **[Cancel]** while the "Protect" setting is active, the "-- Protect -- Discard Current Master" message is on appears each time you press  key or  key.
- The screen shows the message below when:
 - setting the Print Cylinder (Drum) that has been removed without the "Confidential" operation, or
 - the machine goes into the sleep mode after a certain period of time has passed after the confirmation message was displayed, and then the sleep mode is cancelled (or the power is turned ON).

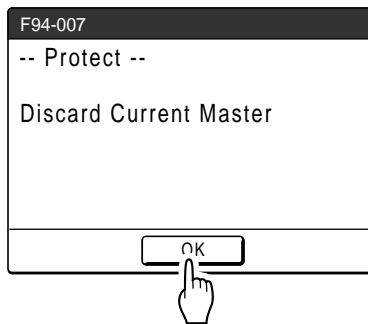

Touch **[OK]** to discard the master remaining on the Print Cylinder (Drum).

Storage and Scan Modes (Option)

About Storage

Storage is a function that allows you to save original data to memory.
Storage memory is available when Document Storage Card DM-128CF is attached.
You can use the Editor function to edit scanned data and to save it into memory.

Important!:

- The storage function is not available in machines equipped with the optional RISO Controller PS7R.

Storable Original Data

Original data created on a computer and sent to the printer, as well as original data scanned in scan mode can be stored.

See the Printer Driver User's Guide for information on storing original data sent from a computer.

See [p.196](#) for information about scan mode.

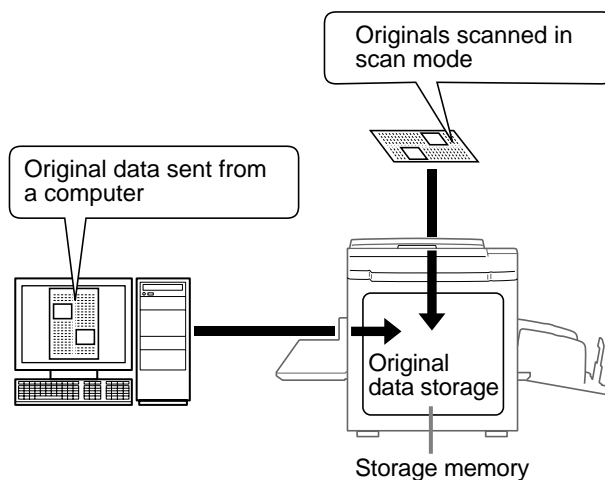

Stored data is managed as "Storage Data", and unless expressly deleted, will not be cleared if you press the  key or turn the machine off.

Important!:

- We can not guarantee stored data against loss caused by disasters or unforeseen events. We recommend that you use your computer to back up any important documents.

Note:

- You can easily delete unnecessary storage data when remaining memory is limited. The remaining memory is displayed in the bottom right corner of the Storage Selection screen.
[p.206](#)
- 6 folders exist for storing data. If you plan to use folders in common with others, we suggest that you create folder storage conventions (for example, categorized by department or data type).
Folder names can be changed in Admin..
[p.175](#)
- You can change the order of the storage data.
[p.207](#)

Retrieving Storage Data

You can do the following when printing with stored data.

- Repeatedly retrieve and print previously stored data. This saves you the trouble of rescanning documents when printing the same materials.

☞ p.195

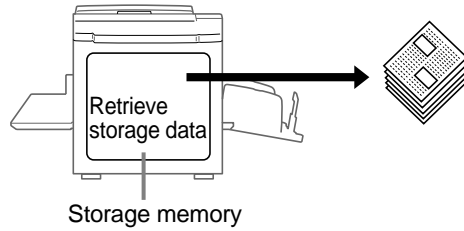

- If the stored data contains multiple pages, you can choose to output all pages, only odd or even pages, or even indicate the specific pages to print using “Output”.
- You can also combine and print stored data with a hard-copy original.

☞ p.208, ☞ p.210

Converting Hard-copy to Stored Data (Scan Mode)

About Scan Mode

Scan mode is a function that allows you to scan a hard-copy original with the machine's scanner to save as storage data.

You can repeatedly retrieve and print previously scanned and stored original data. This saves you the trouble of rescanning documents when repeatedly printing the same materials.

☞ p.195

This function also prevents documents from getting lost or damaged over time.

Note:

- You can easily delete unnecessary storage data when remaining memory is limited.

The following functions can be used in scan mode: See the explanation of each function for more details.

- Image (☞ p.70)
- Contrast (☞ p.77)
- Size (enlargement/reduction) (☞ p.78)
- Dot Process (☞ p.72)
- Contrast Adj (☞ p.74)
- Tone Curve (☞ p.75)
- Multi-Up Print (☞ p.87)
- Easy 2Color (☞ p.46)
- Preview (☞ p.109)
- Book Shadow (☞ p.84)

The following functions are specific to scan mode.

- Format (☞ p.203)
- Color (☞ p.197, ☞ p.199)

Scanning an Original for 1-Color Printing

1 Select a scan mode.

See p.25 for information about selecting a scan mode.

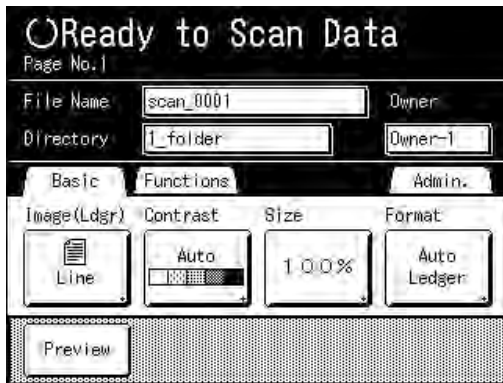

2 Place the original.

See step 5 of "1-Color Printing" (p.51).

Go to step 4 if you are not specifying folder, data, or owner name. If no settings are configured, data is stored by default (Data Name: scan_001, Save Location:1_folder, Owner:Owner-1).

3 Setting data information.

Sets the data name, save location and owner name.

p.201

4 Setting required functions.

Set the required functions for scanning the original.

Note:

- See the previous section for the functions that can be set.
- You can instantly check scanned data by enabling "Preview".

Important!:

- Set "Format" when scanning custom-sized originals.
p.203

◆ To specify the original color:

You can specify the print color of the data you retrieve for printing.

If a cylinder (drum) of a color differing from the print color selected is present, a message is displayed.

Note:

- The factory setting is **[No Entry]**.
There is no particular need to set if printing 1-Color originals.

1) Touch **[Functions]**.

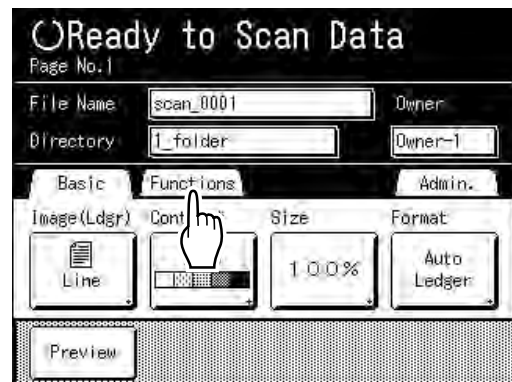

2) Touch **[Color]**.



The Color screen appears.

3) Touch **[Mono-Color]**.

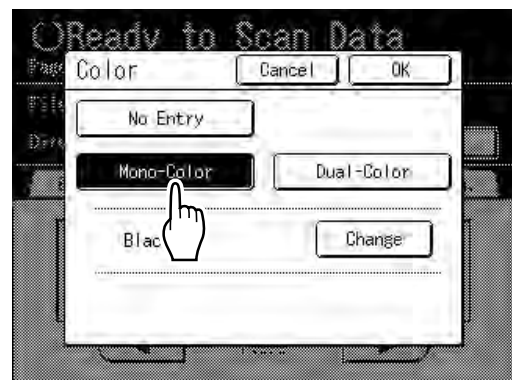

4) Touch [Change].

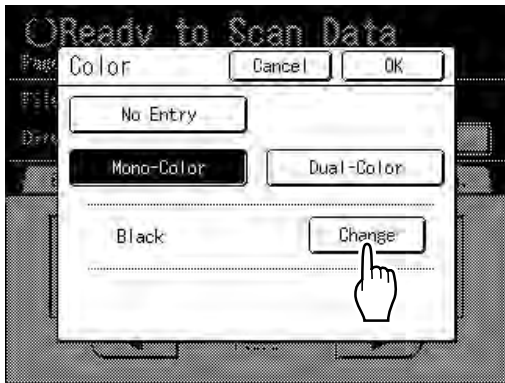

5) Touch the button of the color to set and then touch [OK].

Note:

- The previously set color name displays on the Change screen.

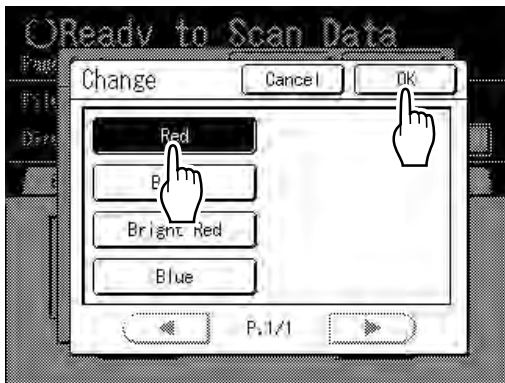

Returns to the Color screen. The Color setting is updated.

6) Touch [OK].

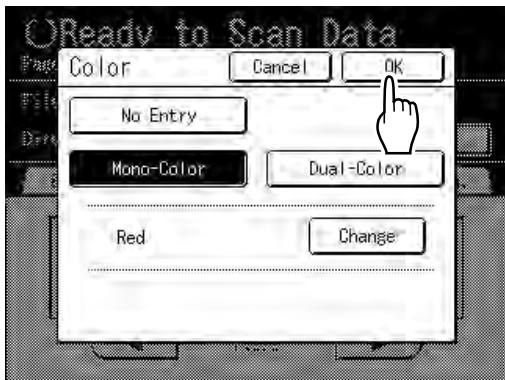

5 Press the  key.

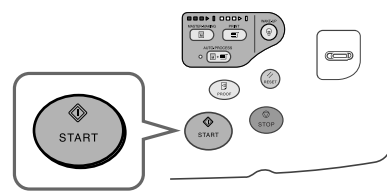

The scan starts.

Note:

- After scanning the original, a preview shows on the display if "Preview" is set.

6 Repeat steps 2, 4 and 5 if the original has multiple pages.

Note:

- If multiple originals are combined on the ADF unit (option) and "Auto Process" is set to ON, all originals will be scanned using the same settings.

Check the  key indicator to determine if "Auto Process" is ON or OFF (illuminated indicates ON).

If "Auto Process" is OFF, press the  key for each original.

7 Touch .

Once the original to be saved as one set of data is scanned, touch .

A confirmation screen appears.

8 Touch [Yes].

The data is saved.

Press the  key to exit scan mode.

Scanning Originals (2) for 2-Color Printing

Originals from Cylinder (Drum) 1 and Cylinder (Drum) 2 are read and stored as one piece of data.

1 Select a scan mode.

See p.25 for information about selecting a scan mode.

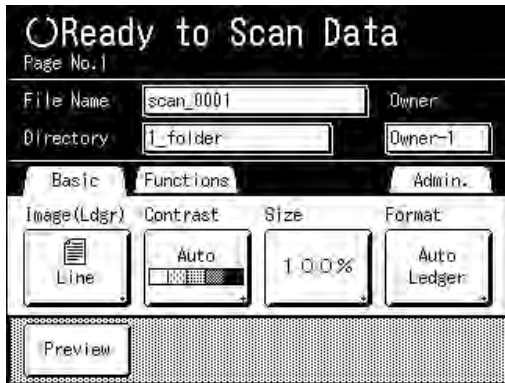

2 Place the Original for Cylinder (Drum) 1.

See step 5 of "2-Color Printing" (p.41).

Procedures are the same for using the ADF unit (option).

Go to step 4 if you are not specifying folder, data, or owner name. If no settings are configured, data is stored by default (Data Name: scan_001, Save Location:1_folder, Owner:Owner-1).

3 Set data information.

Sets the data name, save location and owner name. p.201

4 Touch [Functions].

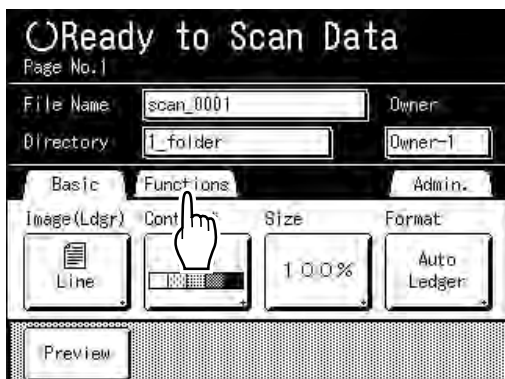

5 Touch [Color].



The Color screen appears.

6 Touch [Dual-Color].

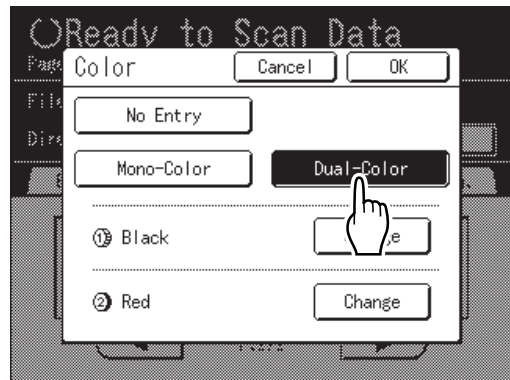

7 Check the cylinder (drum) color.

To change the ink colors on Cylinder (Drum) 1 and Cylinder (Drum) 2, touch **[Change]** for each and choose from among the displayed colors.

Note:

- The previously set color name displays on the Change screen.

8 Touch [OK].

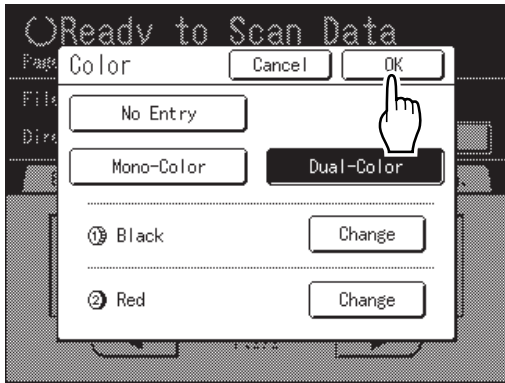

The color specified for the original is confirmed and the screen returns to the Scan Basic Screen.

9 Apply the required settings to the original for Cylinder (Drum) 1.

Set the required functions for scanning the original.

Note:

- See (p.196) for the functions that can be set.
- You can instantly check scanned data by enabling "Preview".

Important!:

- Set "Format" when scanning custom originals. (p.203)

10 Press the key.

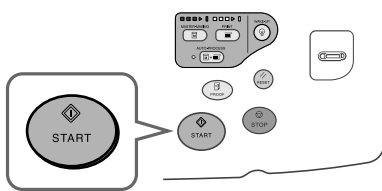

Scan of the original for Cylinder (Drum) 1 starts.

Note:

- After scanning the original, a preview appears on the display if "Preview" is set.

11 Place the original for Cylinder (Drum) 2.

Step 8 of "2-Color Printing with 2 Originals" (p.43)

This step is not needed if the originals for Cylinder (Drum) 1 and Cylinder (Drum) 2 are placed together on the ADF unit (option).

12 Apply the required settings to the original for Cylinder (Drum) 2.

13 Press the key.

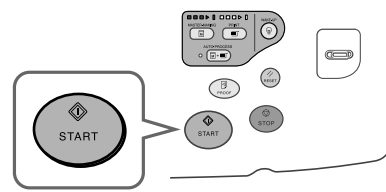

Scan of the original for Cylinder (Drum) 2 starts.

Note:

- A preview appears on the display if "Preview" is set.

14 Repeat steps 2, and 9-13 if the original has multiple pages.

15 Touch .

Once the original to be saved as one set of data is scanned, touch .

A confirmation screen appears.

16 Touch [Yes].

The data is saved.

Press the  key to exit scan mode.

Setting Data Information

Settings for the data to be scanned and stored are configured on the Scan Basic Screen.

1 Select a scan mode.

See [p.196](#) for information about selecting a scan mode.

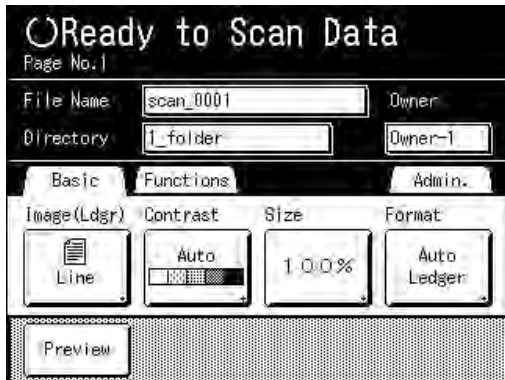

The data name, save location and owner name are automatically allocated when scan mode is started, but you can change this preset information if needed.

Note:

- Default settings for the “Directory” folder can be changed in “Admin.” ([p.174](#))

2 Enter a data name.

- 1) Touch the data name input box.

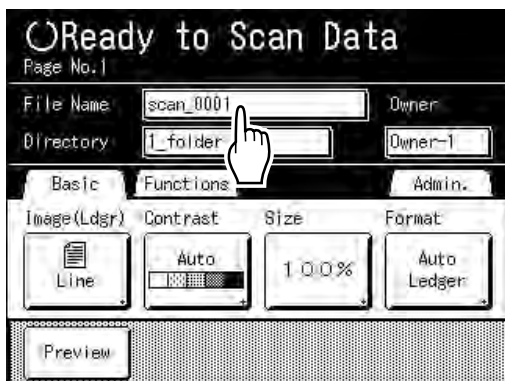

The Rename screen appears.

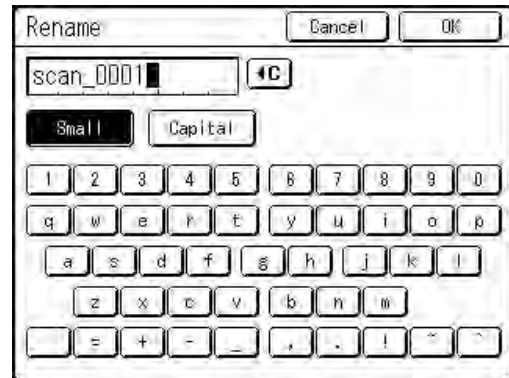

- 2) Touch the **C** button to delete the current name.

Note:

- You can also press the **C** key to delete.

- 3) Touch the text button and enter the data name one character at a time. Touch the Text Type button to change the display, and look for the text you want to enter. ([p.142](#))
- 4) Touch **[OK]**. The data name is confirmed and the screen returns to the Scan Basic Screen.

3 Specifying a Save Location

Note:

- If the machine is equipped with the optional RISO Controller PS7R, you cannot specify where to store the data.

- 1) Touch the save location input box.

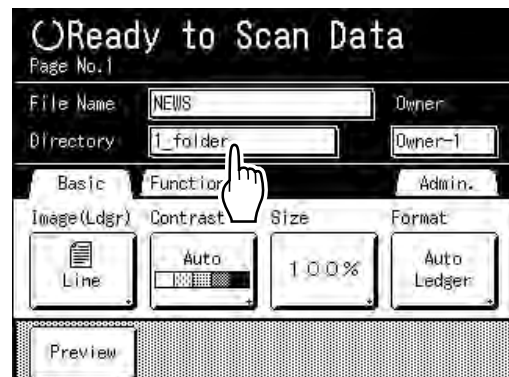

The Directory screen appears.



- 2) Touch the button of the folder in which to save data.

Note:

- The folder name of the "Directory" folder can be changed in "Admin."
(p.175)

- 3) Touch [OK].
The "Directory" folder is confirmed and the screen returns to the Scan Basic Screen.

4 Specifying an Owner.

- 1) Touch the owner input box.

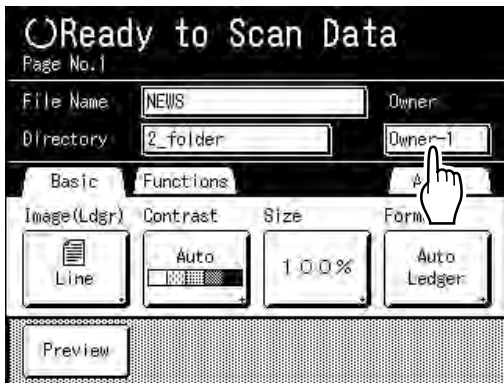

The Owner screen appears.

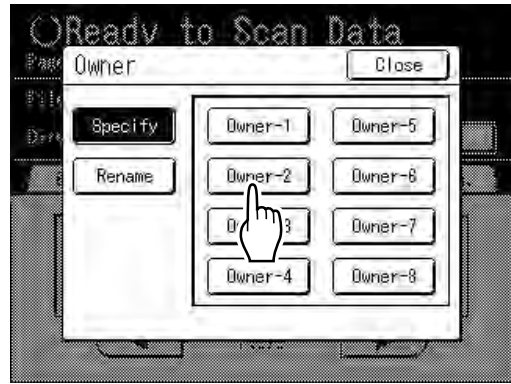

- 2) Touch the button of the owner to set.
The owner name is confirmed and the screen returns to the Scan Basic Screen.

Tip:

Changing the Owner Name

- 1) Touch [Rename] on the Owner screen.

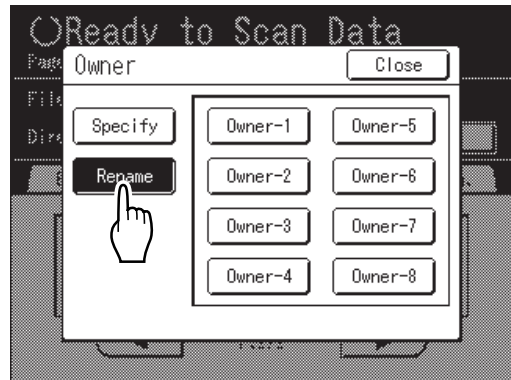

Touch the button of the owner to rename.
The Rename screen appears.

- 2) Touch the [C] button to delete the current name.
- 3) Enter the Owner name.
- 4) Touch [OK].

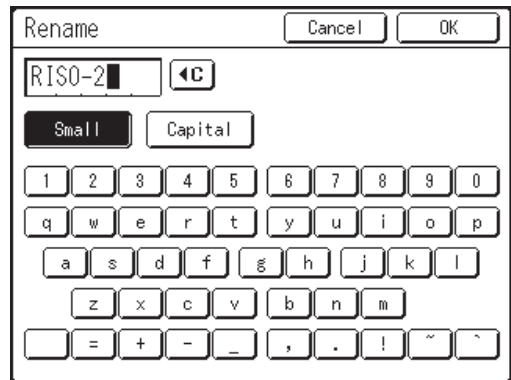

The owner name is confirmed and the screen returns to the Owner screen.

Specifying Paper Size

Specify the size at which to save the scanned original.

If the original is standard-sized, it will be saved as-is with **[Auto]**.

If the original is custom-sized, use the Format screen to save at size that differs from the size of the original.

1 Touch **[Format]** on the Scan Basic Screen.

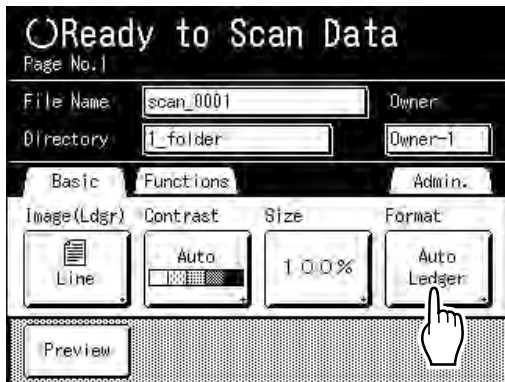

The Format screen appears.

2 Touch the paper size button to be set.

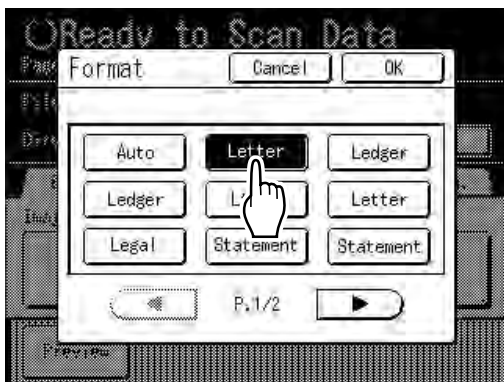

If you select **[Auto]**, the same size as the original will automatically be set.

3 Touch **[OK]**.

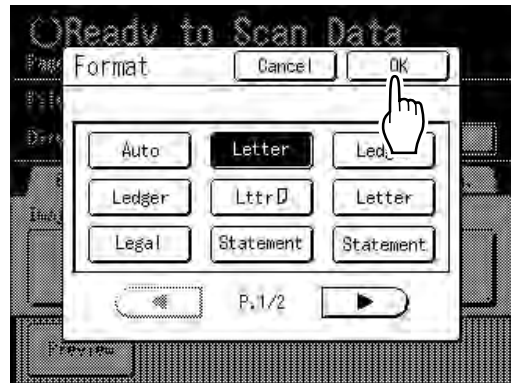

The paper size is confirmed and the screen returns to the Scan Basic Screen.

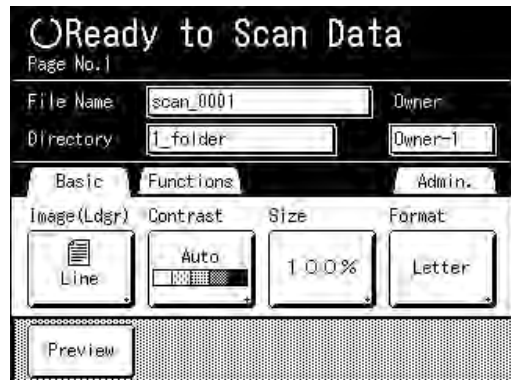

Retrieving Stored Data and Printing

[Storage Memory]

Retrieving Storage Data

1 Touch [Functions] on the Master Making Basic Screen.



2 Touch [Storage Memory].

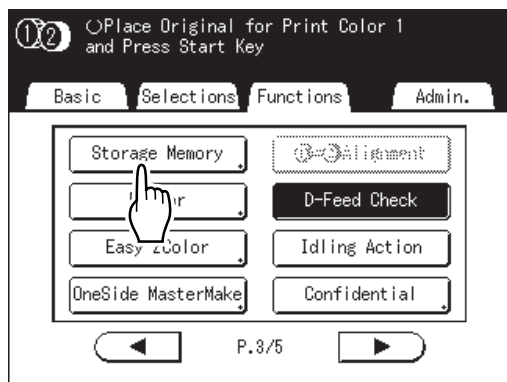

The Storage Selection screen appears.

3 Touch the stored data to print.

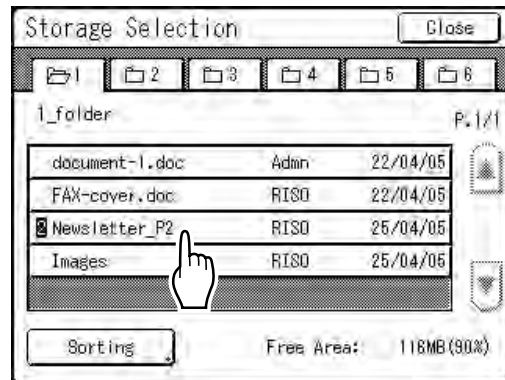

If you are selecting data stored in a different folder, touch that folder's tab.

Note:

- is displayed at the beginning of the data name for 2-Color originals.
- If the stored data is not shown on the screen, touch or to display.

The Storage Retrieve screen appears.

4 Confirm the retrieved data.

Use the thumbnail to determine whether the retrieved data is the data desired.

Note:

- For 2-Color print data, you can switch thumbnails using the color name tab to the bottom right.

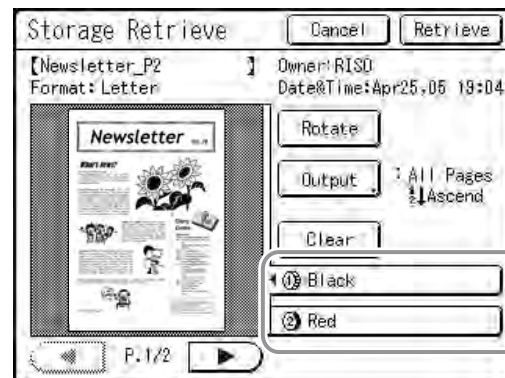

From the Storage Retrieve, you can confirm retrieved data and specify output settings. See p.206 for operational details.

5 Touch [Retrieve].

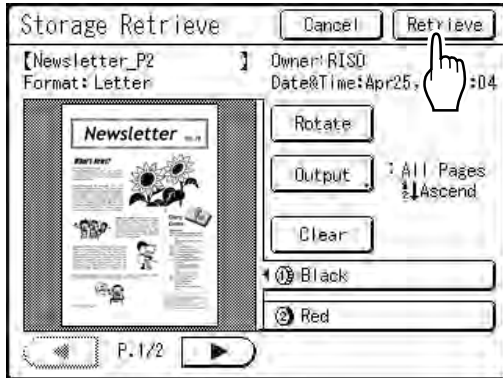

The storage data is retrieved and Storage Mode Basic Screen appears.

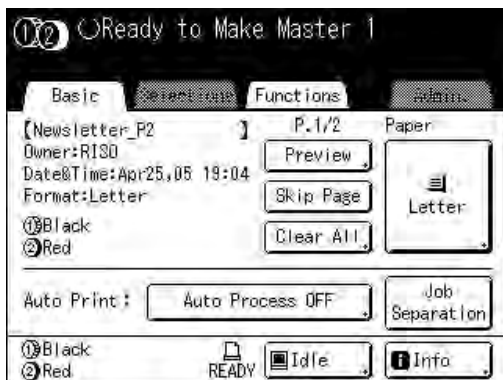

6 Press the key.

A master is made from the data.

After this, please follow the same operations for normally making a master/printing for 1-Color and 2-Color modes.

Using the Storage Retrieve Screen

Each section of the Storage Retrieve screen is shown below.

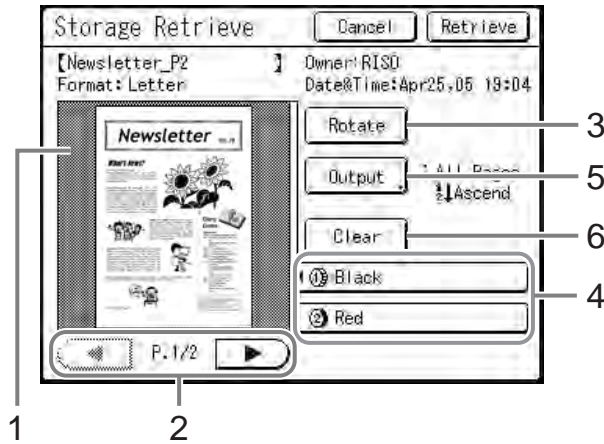

- 1) A thumbnail is displayed for each page.
- 2) If the data contains multiple pages, touch to change page.
- 3) Touch to rotate the storage data 180 degrees and output.
- 4) For 2-color originals, select the tab for each color to display its thumbnails.
- 5) **Output Range**

If the storage data consists of multiple pages, you can specify which pages to print. Touch **[Output]** and the Output screen appears.

To specify a page range, touch the page input box and touch either or to specify the pages.

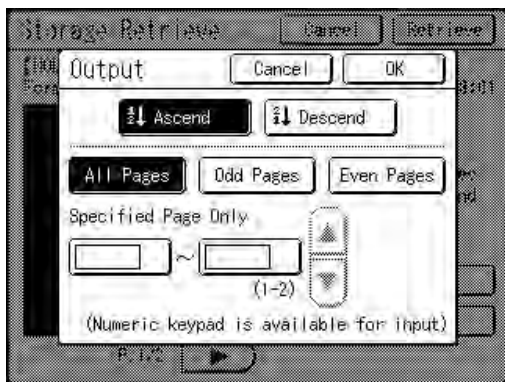

Touch the corresponding buttons to print all pages, only odd pages, or only even pages. You can also specify whether to print the selected pages in **[Ascend]** or **[Descend]** order.

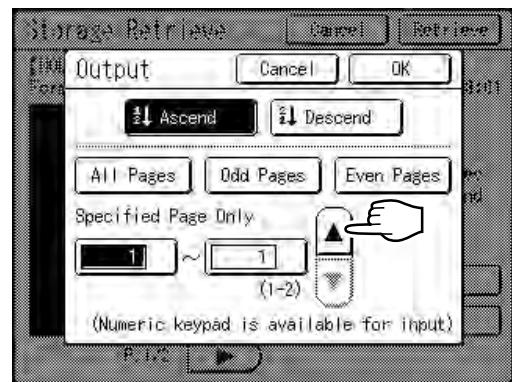

- 6) **Clear**
Touch **[Clear]** and a confirmation screen appears.



Touch **[OK]** to delete the data.

Changing the Data Order

You can change the order of the storage data displayed on the storage data selection screen.

Note:

- The factory setting is “Date - Ascend”.

1 Touch [Sorting].

Note:

- **[Sorting]** is inactive if there is no storage data or only one stored item.

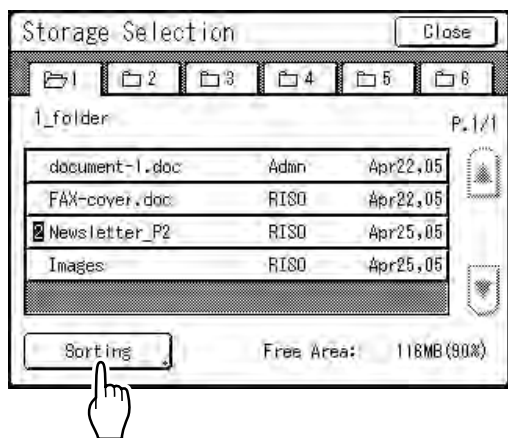

2 On the Sorting screen, touch the button of the order you want.

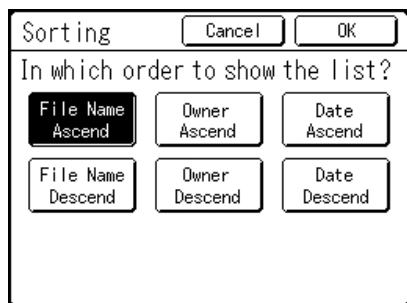

3 Touch [OK].

Returns to the Storage Retrieve screen.

Overlaying Storage Data onto a 1-Color Print Job [Overlay]

When 1-Color printing, you can overlay stored data onto a hard-copy original. For example, this function can be used to overlay a stamp over multiple originals indicating “Sample”. This function cannot be used with the following functions.

- Ink Saving
- Top Margin
- Side Margin
- Storage Memory (“Overlay” images cannot be stored.)
- When sending original data from the computer

1 Place an original and load paper.
Place the original on Stage Glass or in ADF unit (option). See the “Basic Operations” chapter for information on placing the original.

2 Touch [Functions] on the Master Making Basic Screen.

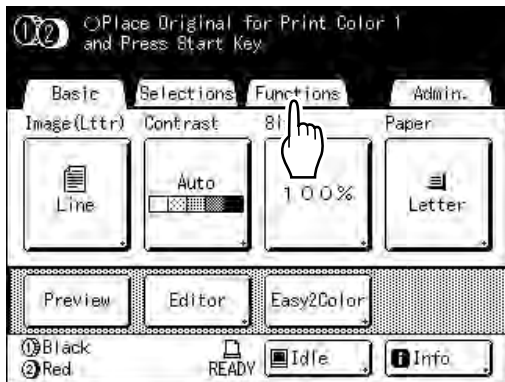

3 Touch [Overlay].



The Storage Selection screen appears.

4 Select the storage data to overlay.

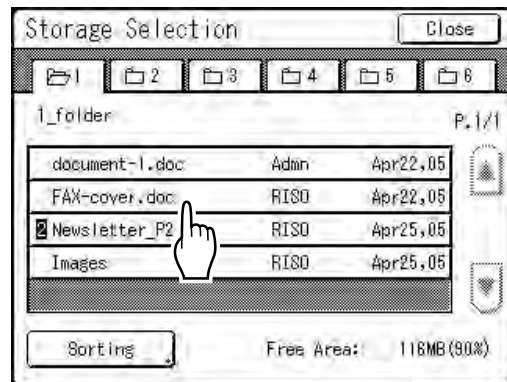

The Storage Retrieve screen appears.

5 Confirm the storage data and touch [Retrieve].

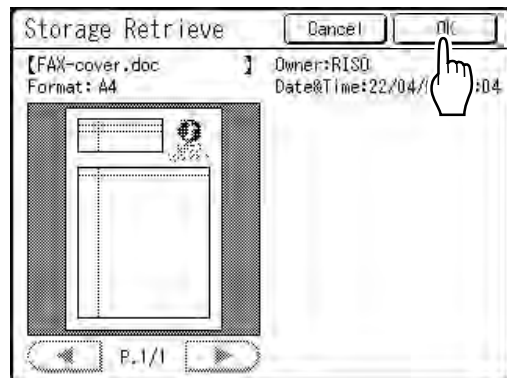

Note:

- If the storage data is separated into two colors, specify the color (cylinder (drum)) of the side you want to print.

“Overlay” is set and the screen returns to the Functions screen.

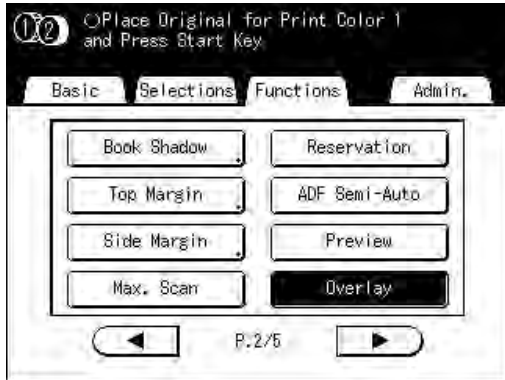

6 Print.

For subsequent operations, see step 6 of “1-Color Printing” (p.59).

Tip: Overlying Storage Data

The stored data overlays at the size it was saved. You cannot magnify/decrease the size to match the original or paper size.

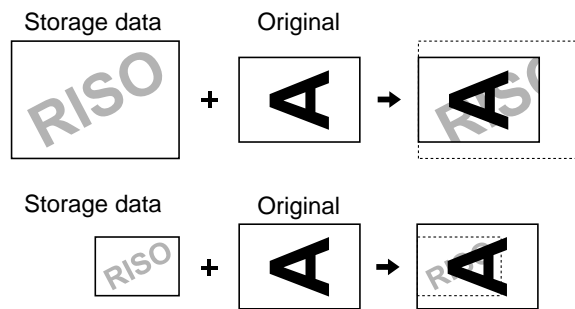

The storage data is overlaid after being centered at the top of the original. You cannot adjust the overlay position.

2-Color Printing with the Original and Storage Data [Stamp]

When 2-Color printing, you can create a master of the hard-copy original on one Cylinder (Drum) 1 and a master of the storage data on Cylinder (Drum) 2 in order to 2-Color print.

For example, if you specify data for Company logo, etc., that color insignia can be printed on consecutive pages.

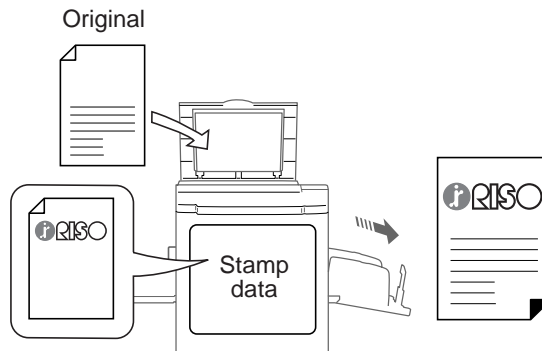

Important!:

- When “Stamp” is used, the printer automatically scans the hard-copy original and creates a master on Cylinder (Drum) 1 (the black cylinder (drum)), and creates a master of the storage data on Cylinder (Drum) 2 (the color cylinder (drum)).
If both cylinders (drums) are color cylinders (drums), the original is automatically allocated to Cylinder (Drum) 1 and the storage data to Cylinder (Drum) 2.
You cannot set a specific cylinder (drum).

This function cannot be used with the following functions.

- Easy 2Color
- Storage Memory (“Stamp” images cannot be stored.)
- When sending original data from the computer

Registering a Stamp Data to insert

Stamp data must be pre-registered from storage data.
Up to 10 data can be registered as Stamp Data.
See [p.194](#) for information on creating storage data.

1 Touch [Stamp Data] on the Admin. screen.

See [p.173](#) for operational details of the Admin. screen.

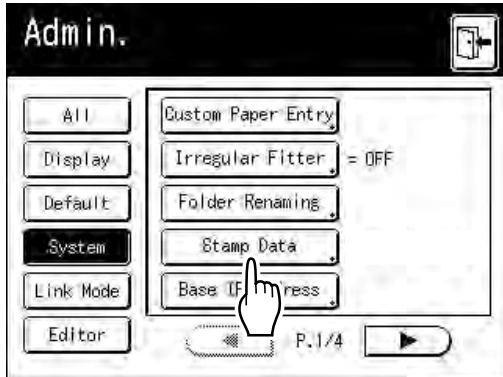

The Stamp Data screen appears.

2 Touch an unused button.

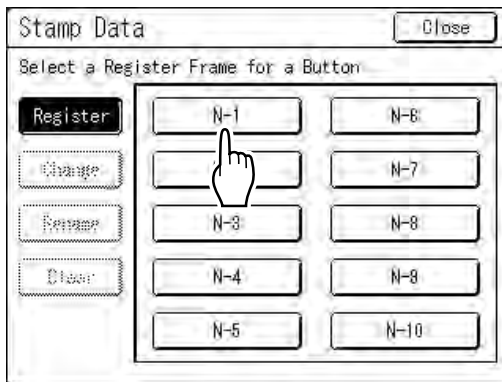

Unused buttons are displayed with a solid line.
Greyed-out buttons are not available (registered another data).

3 Select the storage data to use as the [Stamp].

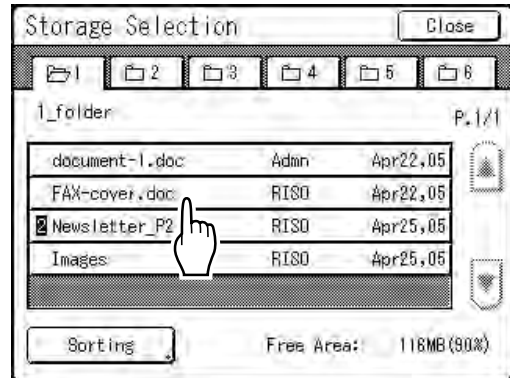

Note:

- See [p.204](#) for details on using the Storage Selection screen.

4 Confirm the storage data and touch [OK].

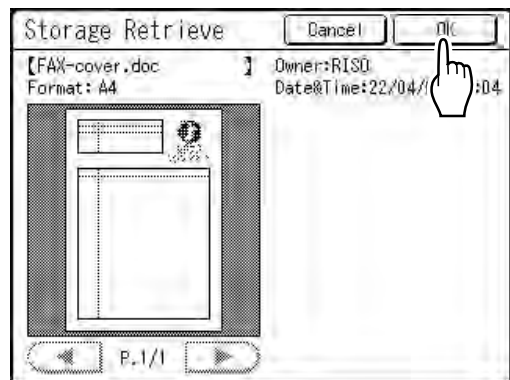

Note:

- See [p.206](#) for information about the Storage Retrieve screen.

Returns to the Stamp Data screen.

5 Touch [Close].

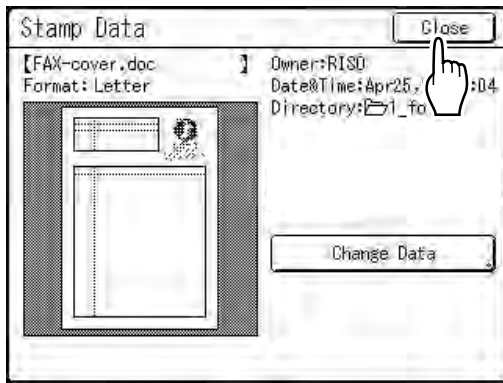

Note:

- To change the Stamp data, touch **[Change Data]**.

The Stamp Data screen appears.

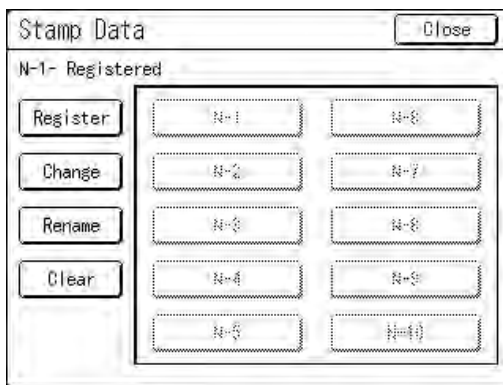

Proceed to the step 2 (p.213) of "Renaming the Stamp Data" if necessary.

6 Touch .

Renaming the Stamp Data

1 Touch [Stamp Data] on the Admin. screen.

See p.173 for operational details of the Admin. screen.

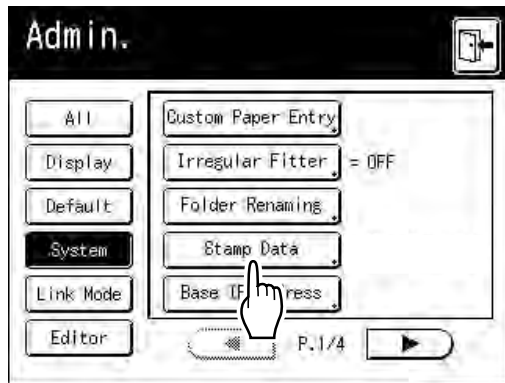

The Stamp Data screen appears.

2 Touch [Rename].

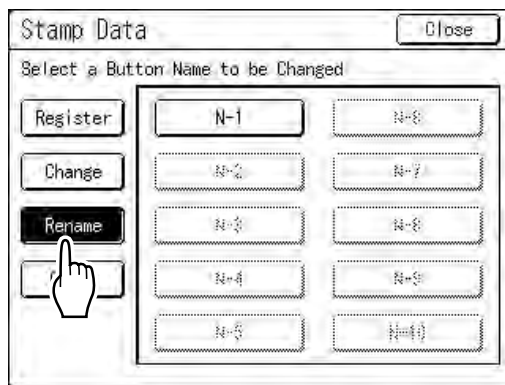

3 Touch the button to rename.

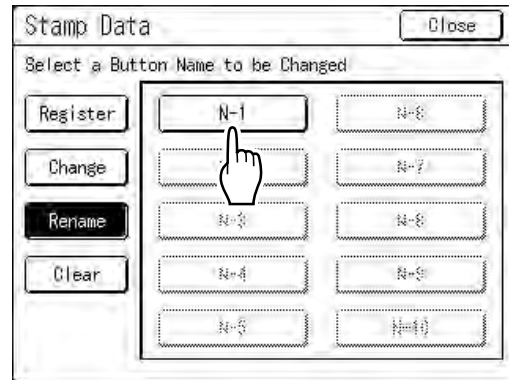

Greyed-out buttons are not available (no Stamp Data has been registered yet).

4 Touch [C] to delete the existing name.

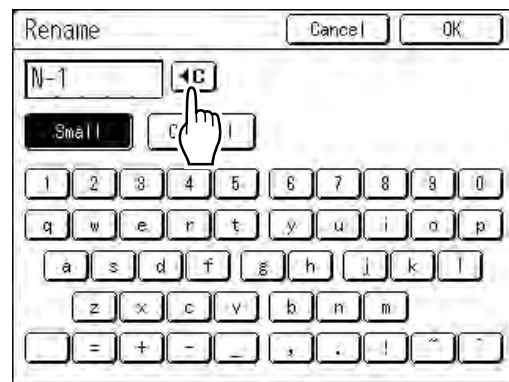

Note:

- You can also use  button to clear the entry.

5 Touch character buttons to enter a new name.

Change capitalization by selecting [Small] or [Capital] button.

- See p.142 for renaming screen.

6 Touch [OK] after entering all the characters.

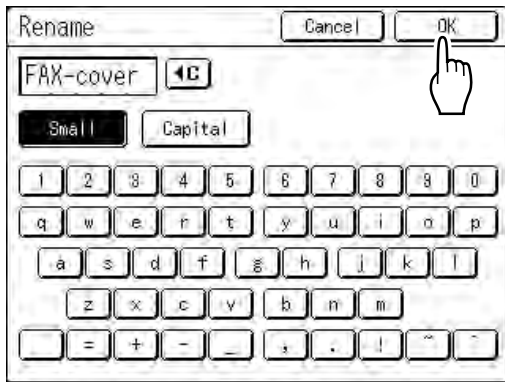

The entered name is registered and returns to the Stamp Data screen.

7 Touch [Close].

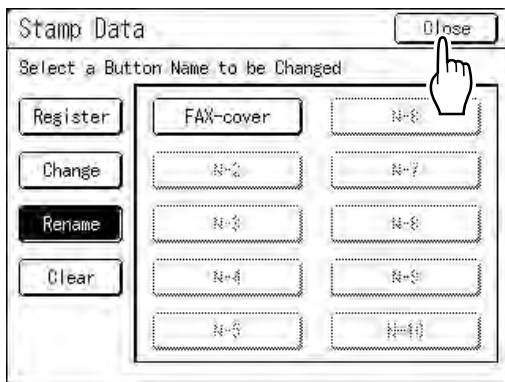

Returns to Admin. screen.

8 Touch .

2-Color Printing with [Stamp]

Pre-select 2-Color Printing.

- 1 **Place an original and load paper.**
Place the original on Stage Glass or in ADF unit (option).
See the “Basic Operations” chapter for information on placing the original.

- 2 **Touch [Functions] on the Master Making Basic Screen.**

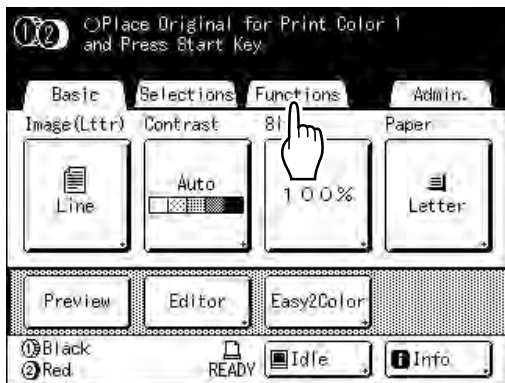

- 3 **Touch [Stamp].**

Important!:

- If data for the “Stamp” is not registered, the [Stamp] button does not display on the Functions screen.



- 4 **Touch the button of the Stamp Data to use.**

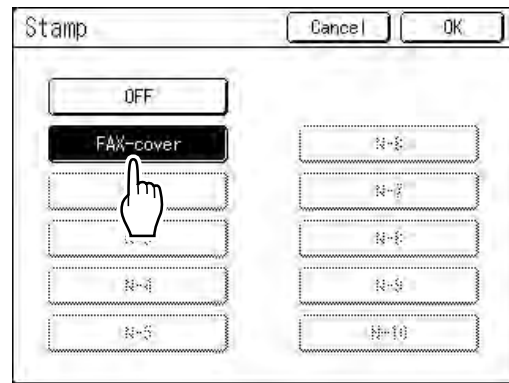

Greyed-out buttons are not available (no Stamp Data has been registered).

- 5 **Touch [OK].**

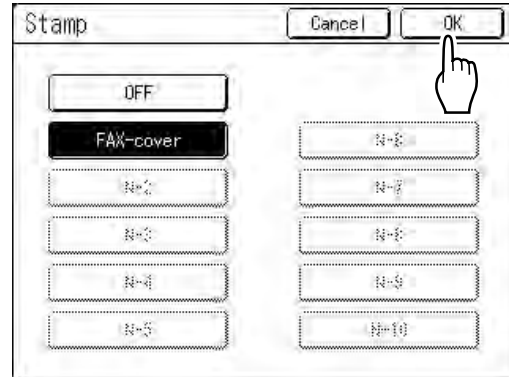

Stamp is set.

- 6 **Set the print functions.**

You can make adjustments to the print functions as needed.

7 Press the  key.

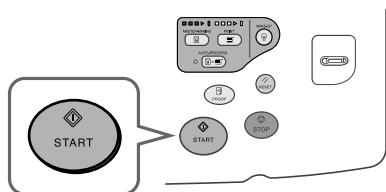

A master is made from the hard-copy original and the stamp data, and a proof printed.

For subsequent operations, follow the same procedures from step 11 (p.44) of “2-Color Printing with 2 Originals”.

Changing the Stamp Data

1 Touch [Stamp Data] on the Admin. screen.

See p.173 for operational details of the Admin. screen.

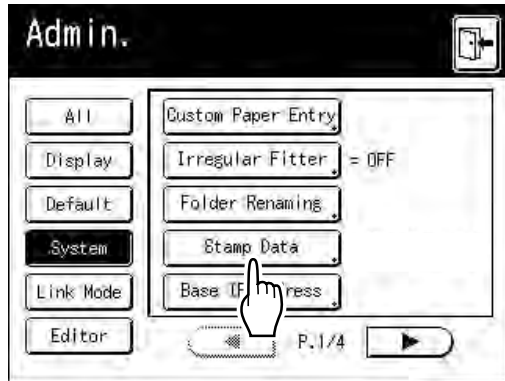

The Stamp Data screen appears.

2 Touch [Change].

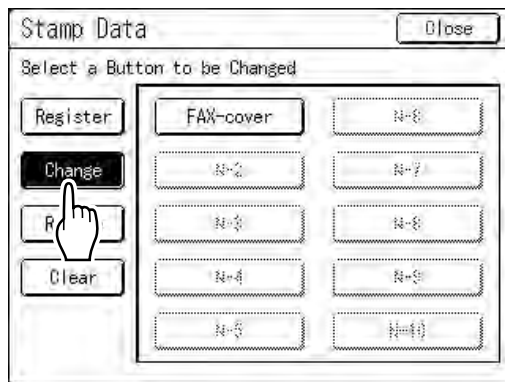

3 Touch the button to change.

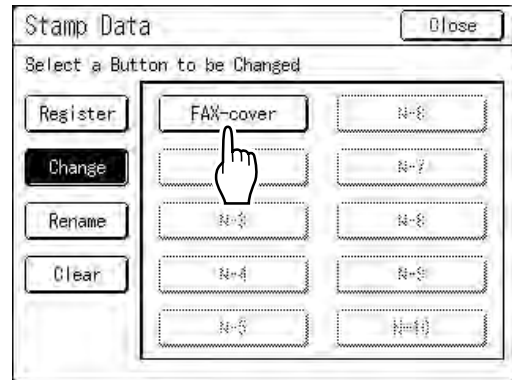

4 Touch [Change Data].

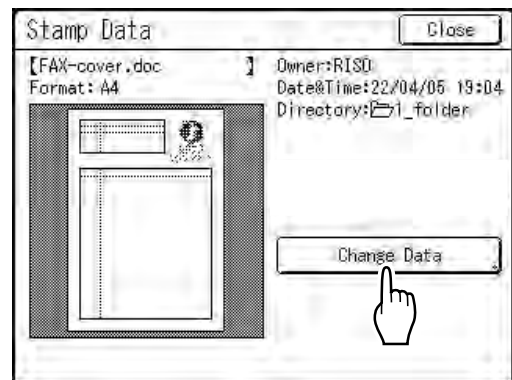

5 Select the storage data to use as the new Stamp Data.

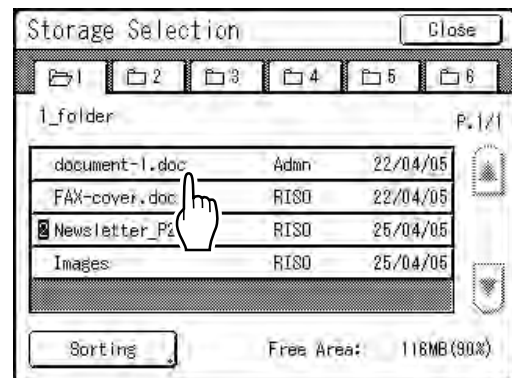

Note:

- See p.204 for information about the Storage Selection screen.

6 Confirm the storage data and touch [OK].

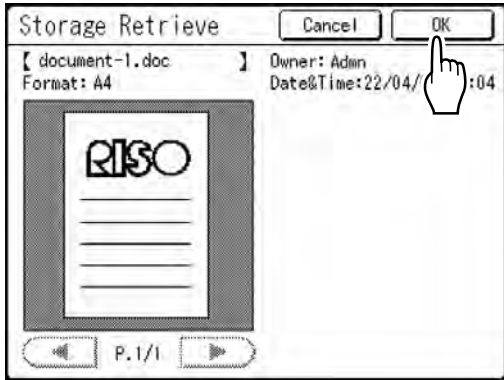

Note:

- See p.206 for information about the Storage Retrieve screen.

Returns to the Stamp Data screen.

7 Touch [Close].

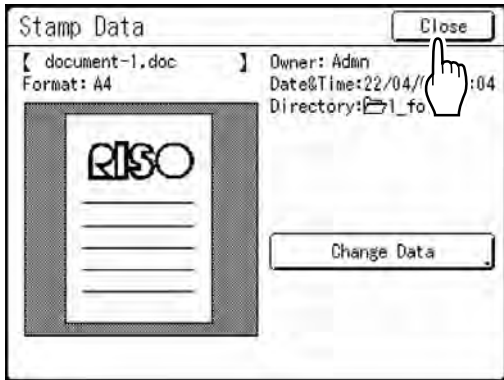

The data is changed and returns to the Stamp Data screen.

8 Touch [Close].

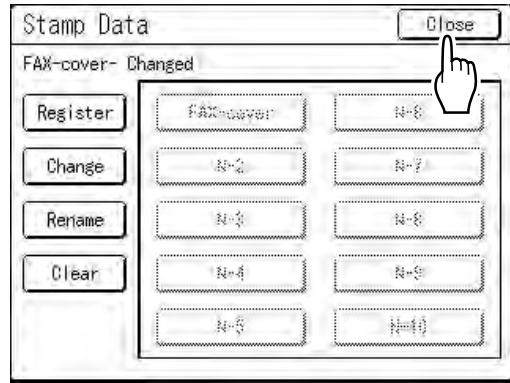

Returns to Admin. screen.

9 Touch [Return].

Deleting a Stamp Data

1 Touch [Stamp Data] on the Admin. screen.

See p.173 for operational details of the Admin. screen.

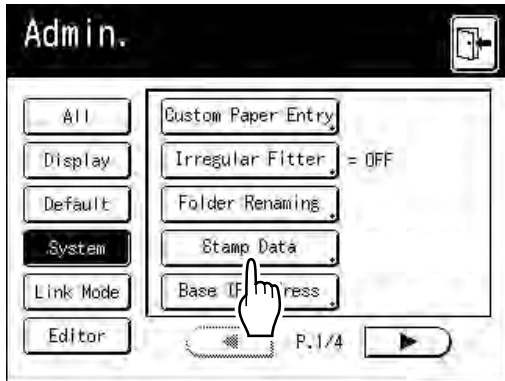

The Stamp Data screen appears.

2 Touch [Clear].

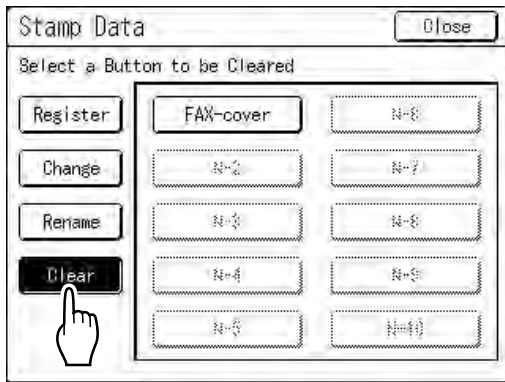

3 Touch the button to delete.

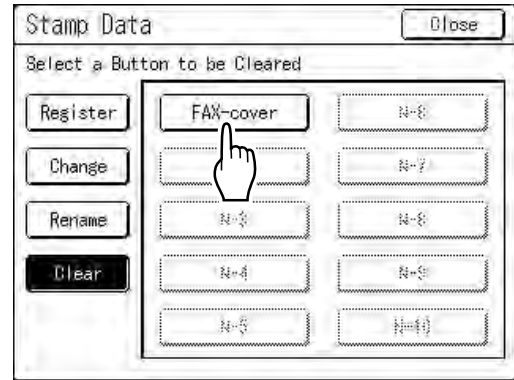

4 Touch [Unselect].

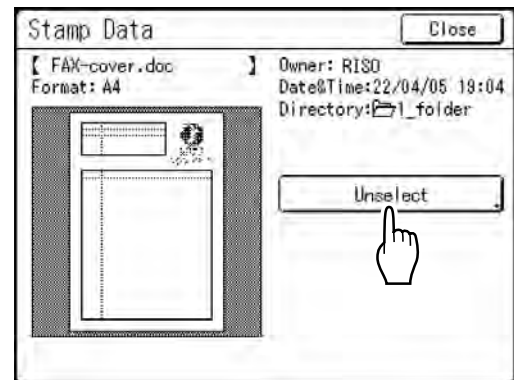

5 Touch [OK].

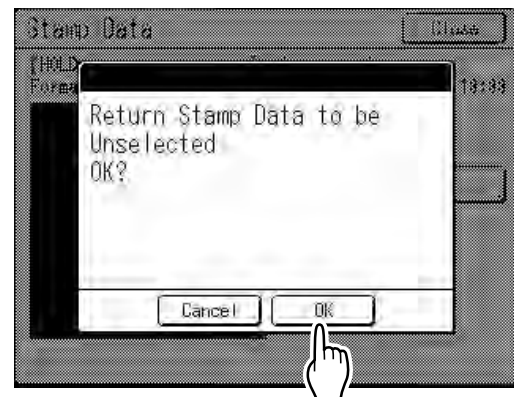

Returns to Stamp Data screen.

6 Touch [Close].

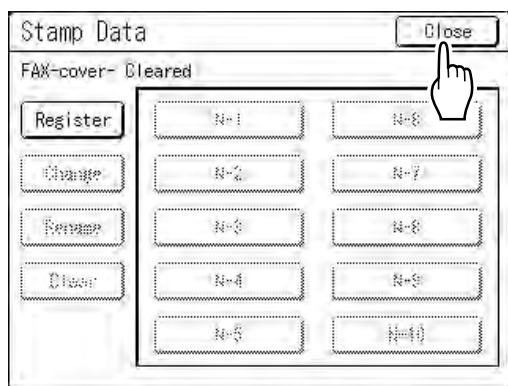

7 Touch .

When using a Linked Printer (sold separately)

Print Functions for Using Linked Printers

The machine may be connected with Linked Printers for more convenient operations.

Important!:

- The optional RISORINC-NET is required in order to connect the machine and Linked Printers.

2 special printing functions Auto-Link Function and Link Mode are available;

◆ Auto-Link Function

(This function is not available for MZ990/790U.)

Automatically select an output device, the machine or a Linked Printer, based on a pre-determined number of copies (Link-Free Volume).

☞ p.178

“Auto Link” can only be used for 1-Color printing. It cannot be used for 2-Color printing.

In order to create and use storage data, the printer must be equipped with storage memory.

☞ p.194

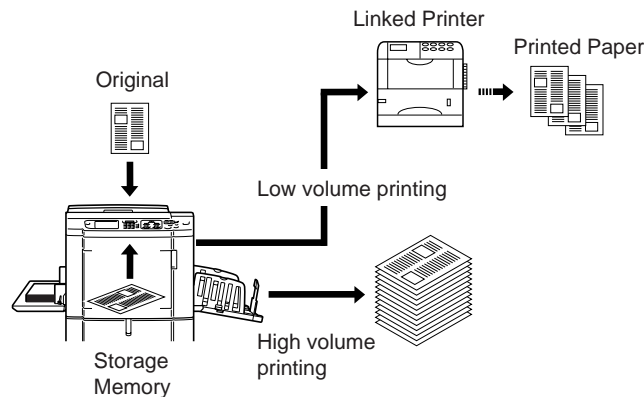

Automatically select an output device based on number of copies when printing from a computer. (When “Online Auto-Link” is enabled)

☞ p.178

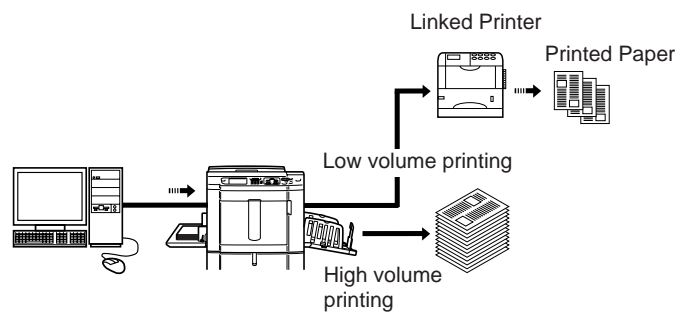

◆ Link Mode Function

The original is scanned on the machine and printed from the Linked Printer.

☞ p.228

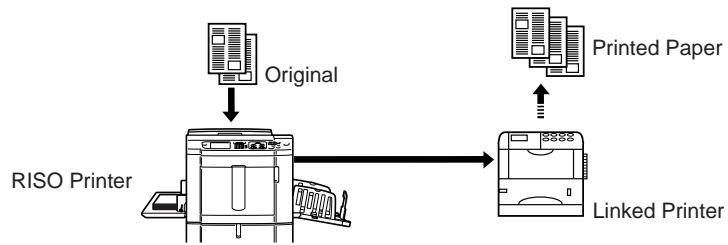

- Special Linked Printer functions such as double-sided printing can be achieved.
- When printing a high volume of copies of the scanned original, it is more economical to use RISO Printer, if printing few copies, using the Linked Printer is more efficient.

Setting up a Linked Printer [Link Properties]

Linked Printer data must be entered in the machine in order to operate.

Important!:

- Make sure that the Linked Printer is physically connected to the machine. A Linked Printer cannot be recognized by the machine unless physically connected.
- Unless the Linked Printer data is entered in the machine, the device will not print, and its optional features will not be available.
- Enter information for each attached Linked Printer one device at a time.
- When there's only one Linked Printer (sold separately) to the machine, set "Linked Printer" as "One-to-One".

Note:

- "Link Properties" are explained below.
See "Link Mode" (p.178) for more information about Link Mode and other Admin. settings.

Linked Printer Setup List

== : Initial setting (factory default)

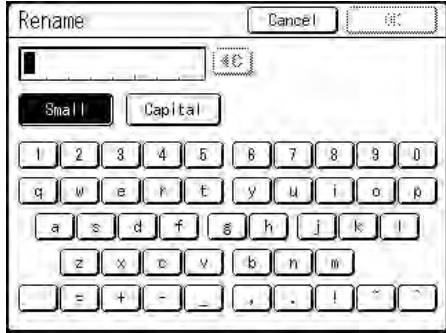
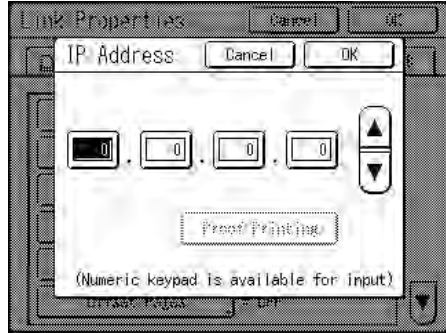
Functions	Description	How to Enter
<p>Printer Name Enter a name for the Linked Printer.</p> <p>Note:</p> <ul style="list-style-type: none"> • The entered name will be displayed on the Link Mode screen. 		 <p>Touch character button to enter a new name. Once the name is entered, touch [OK] to store it as the Printer Name. See "Rename Screen" (p.142) for more details.</p>
<p>IP Address Enter the IP address of the Linked Printer to connect to the network.</p> <p>Note:</p> <ul style="list-style-type: none"> • Touch [Proof Printing] to execute a data transmission test to the Linked Printer. When successful, the test results will print from the Linked Printer. If the test fails, a Pop-Up Message displays. Touch [Cancel] and re-enter correct settings. • [Proof Printing] is disabled until "Base IP Address" is correctly entered on the Admin. screen. (p.175) 		 <ul style="list-style-type: none"> • Use ▲ ▼, or enter using the Print Quantity Keys. • To move to another field, touch the field, or press the (*) key to move.

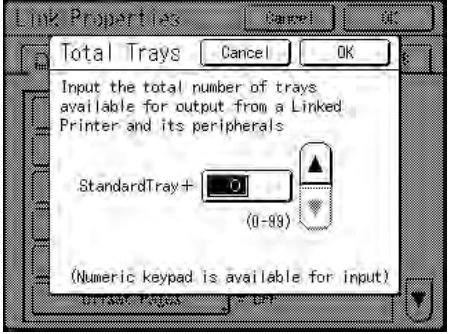
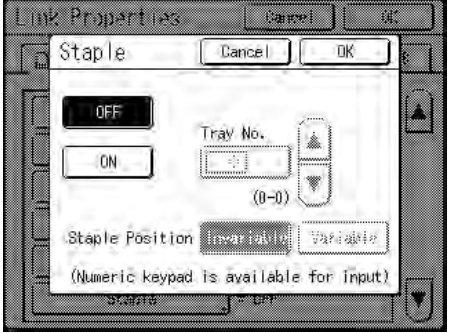
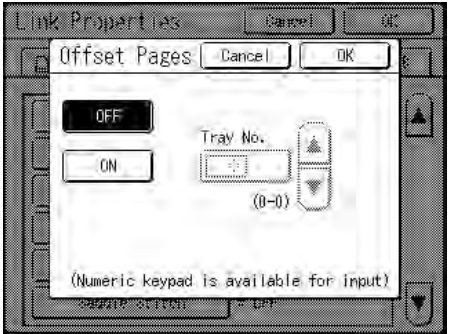
Functions	Description	How to Enter
<p>Total Trays Enter total number of trays other than the Standard Tray.</p> <p>Important!:</p> <ul style="list-style-type: none"> • If the number is less than the number of trays set in other options, other options will be disabled. • Enter the actual number of trays available for the linked printer. Entering incorrect number will cause an error and the linked printer will not print. 	<p>0-99</p>	 <ul style="list-style-type: none"> • When printing from the standard tray of the Linked Printer, enter [0]. • Use ▲▼, or enter using the Print Quantity Keys.
<p>Staple Set "Staple" ON if the device has the capability. Also set the tray number *1 used by the "Staple" function and whether it is fixed/variable.</p>	<p>OFF: No Staple capability (disabled) ON: Staple function available Tray number used, Invariable/variable</p>	 <p>Touch to select a button. Use ▲▼, or enter using the Print Quantity Keys for "Tray No."</p>
<p>Offset Pages Set "Offset Pages" ON if the device has the capability. Also set the tray number *1 used by the "Offset Pages" function.</p>	<p>OFF: No Offset Pages function (disabled) ON: Offset Pages available Tray number used</p>	 <p>Touch to select a button. Use ▲▼, or enter using the Print Quantity Keys for "Tray No." "Offset Pages" and "Punch" may be configured using similar steps.</p>

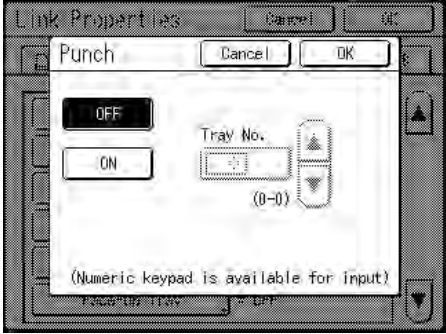
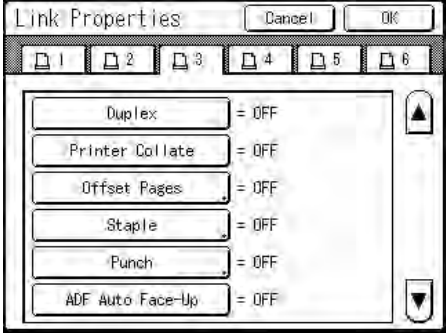
Functions	Description	How to Enter
<p>Punch Set "Punch" ON if the device has the capability. Also set the tray number *1 used by the "Punch" function.</p>	<p><u>OFF</u>: No Punch capability ON: Punch function available Tray number used</p>	 <p>Touch to select a button. Use ▲ ▼, or enter using the Print Quantity Keys for "Tray No." "Offset Pages" and "Punch" may be configured using similar steps.</p>
<p>Duplex Set "Duplex" ON if the device has the capability.</p>	<p><u>ON/OFF</u></p>	 <p>"Duplex", "Printer Collate", "Output Reversal", "ADF Auto Reversal" and "Mailbox" may be configured using similar steps. Touch button to switch between OFF/ON.</p>
<p>Printer Collate Set "Printer Collate" ON if the device has the capability.</p>		
<p>Output Reversal Set "Output Reversal" ON if the device has the capability.</p>		
<p>ADF Auto Reversal Set "ADF Auto Reversal" ON if the device has the capability.</p>		
<p>Mailbox Set "Mailbox" ON if the device has the capability.</p>		

*1 The tray number may differ depending upon the model of the Linked Printer.

Setting up a Linked Printer

- 1 Touch [Link Mode] on the Admin. screen.

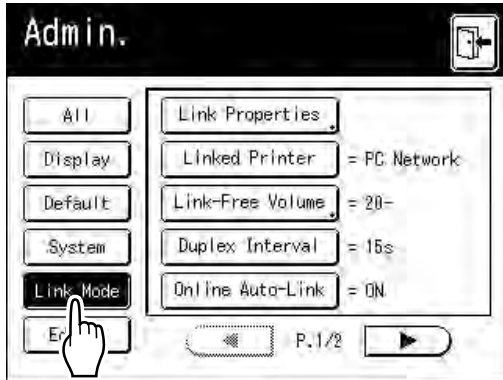

- 2 Touch [Link Properties].

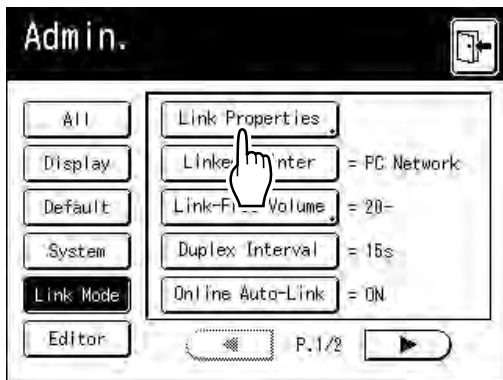

- 3 Select a tab for the Linked Printer.

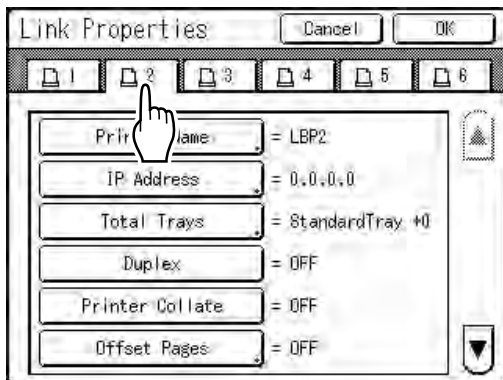

Note:

- Up to 6 Linked Printers may be entered.

- 4 Select the button to enter information.

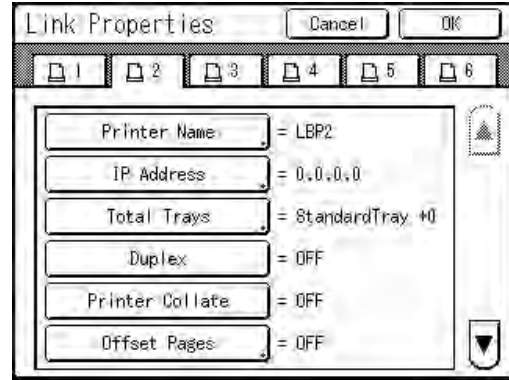

Note:

- To display other functions that are not visible on the screen, touch ▲ or ▼.

- 5 Change settings.

See “Linked Printer Setup List” (p.224) to change settings.

Note:

- If the function has additional Setup screens, enter necessary settings then touch [OK]. Returns to the Link Properties screen. The changes are updated. Touch [Cancel] to cancel the changes and return to the Link Properties screen.

- 6 Touch .

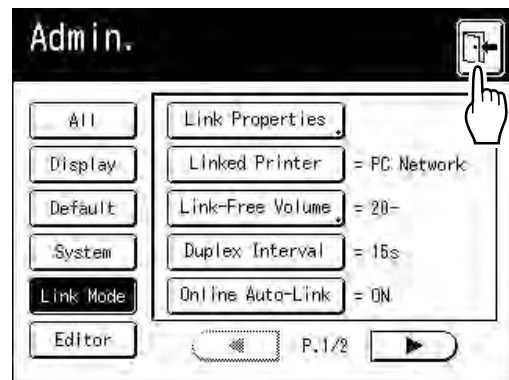



Returns to the Basic Screen. “Admin.” settings are updated.

Printing Scanned Original from a Linked Printer [Link Mode]

The mode in which an original is scanned into the machine and printed from a Linked Printer is called "Link Mode". In Link Mode, the original is printed from the Linked Printer, regardless of the number of copies to print.

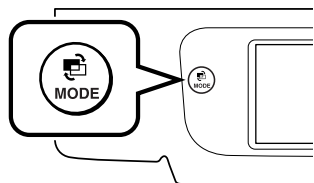
1 Switch to Link Mode.



Press the  key on the machine to switch to Link Mode.
From Mode Screen, touch **[Link Print]** to switch to the Link Basic Screen.
p.24

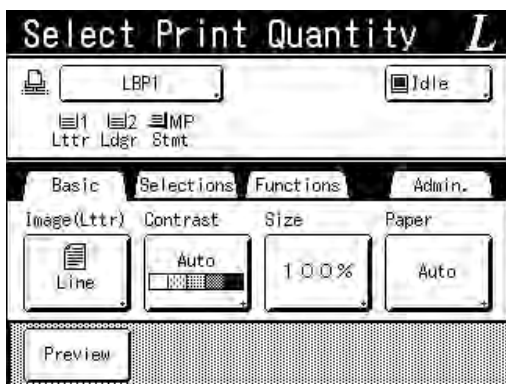

Note:

- While the message "Starting Up RISORINC-NET / Acquiring Linked Printer Configuration Data Please Wait a Moment" is displayed on the machine, the Linked Printer information is being retrieved via the network. Wait until the message disappears.

2 Place the original.

Place the original on Stage Glass or in the ADF unit (option).
For information about placing the original, see step 5 in "2-Color Printing with 2 Originals" (p.41).

3 Select printing paper.

If the Linked Printer has multiple feed trays, touch **[Paper]** to specify the tray (paper size).

- 1) Touch **[Paper]** in the Link Basic Screen.

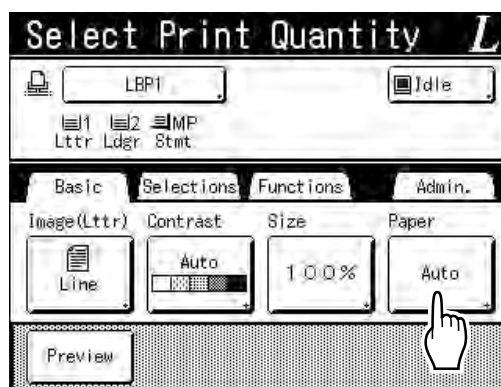

- 2) Select the desired paper size.

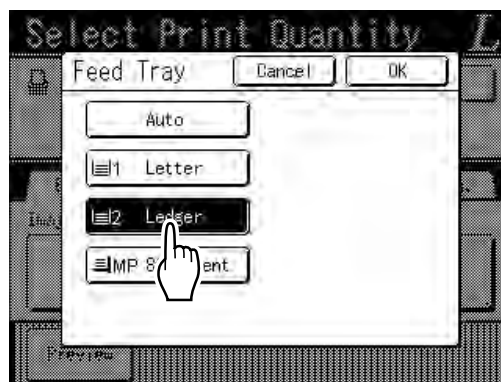

3) Touch [OK].

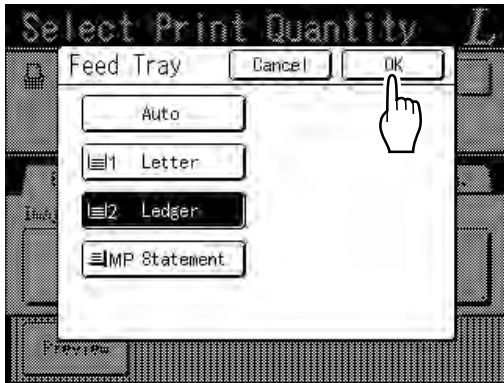

Tip:

Using a Linked Printer's Universal Tray
If the Linked Printer's paper feed tray is set to "Universal", the "Universal" button is displayed on the machine's Feed Tray screen. Follow the steps below to specify the paper size loaded in the Linked Printer's Universal Tray.

1) Touch [Universal] on the Feed Tray screen.

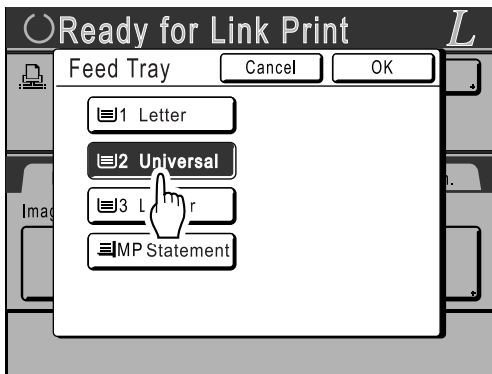

2) Touch the button corresponding to the size of the paper loaded in the "Universal" tray.

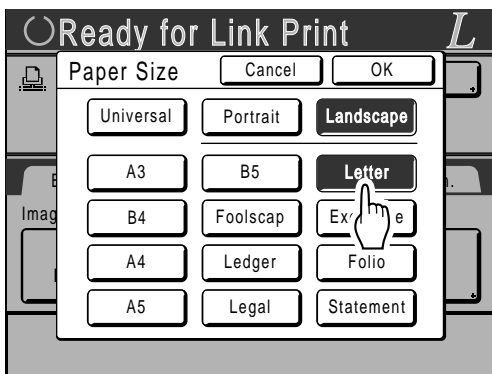

3) Touch [Portrait] or [Landscape].

Note:

- When "Universal", "A3", "B4", "Ledger", "Foolscap", "Legal" or "Folio" is selected in step 2, "Portrait"/"Landscape" options are not displayed.
- If the paper size specified in "Universal" is different to the size of the paper actually set, correct printing will not be possible.

4) Touch [OK].

Returns to the Feed Tray screen. Paper size is updated.

4 Select the print functions as needed.

The following functions are available:

- Image Processing mode (p.70)
- Scanning Contrast (p.77)
- Size (p.78)
- Dot Process (p.72)
- Memory (p.150)
- Contrast Adj (p.74)
- Tone Curve (p.75)
- Book Shadow (p.84)
- Top Margin (p.105)
- Preview (p.109)
- Overlay (p.208)
- Storage Memory (p.204)
- Counter Display (p.169)

Note:

- If the Linked Printer has optional devices such as a duplex unit, the optional functions are also available. (p.231)
- Print Speed, Contrast, or Positioning cannot be adjusted.
- When a computer sends an output signal to the machine while it is in operation, such interrupting data may take priority, initiating a new print job over current one.
We recommend that you set "Reservation" on the Admin. screen to set higher priority on output jobs from Linked Printers. Data received from the computer within specified time frame will not be processed. (p.159)

5 Enter the number of copies using the Print Quantity Keys.

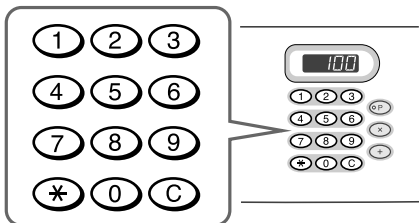

The number is displayed on the Print Quantity Display.

Note:

- To change the number, press the **C** key, then re-enter the correct number.

6 Press the **START** key.

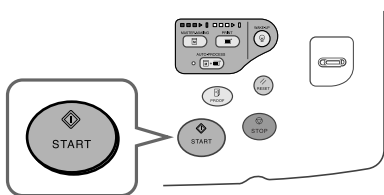

The scan of the original begins.
The scanned original data is sent to the Linked Printer, and the specified number of copies is printed from the Linked Printer.

Note:

- The current settings can be stored in Job Memory for future retrieval of the same settings. p.150

7 Press the **RESET** key when the print job is complete.

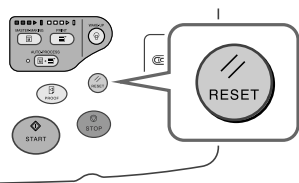

The setting returns to its default value.

Tip:
When multiple Linked Printers are connected to the network

When multiple Linked Printers are connected to the network, output device can be selected as needed.

To output to another Linked Printer, follow the steps below:

- 1) Touch **[Printer Name]** in the Link Basic Screen.

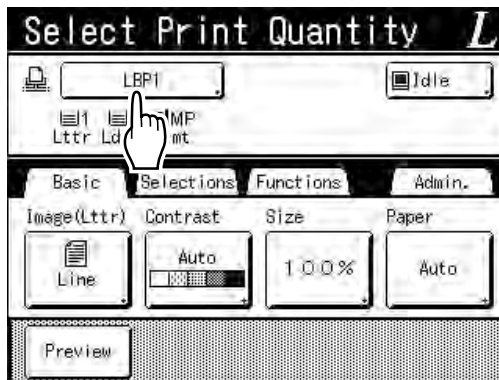

- 2) Select the Linked Printer to print from.

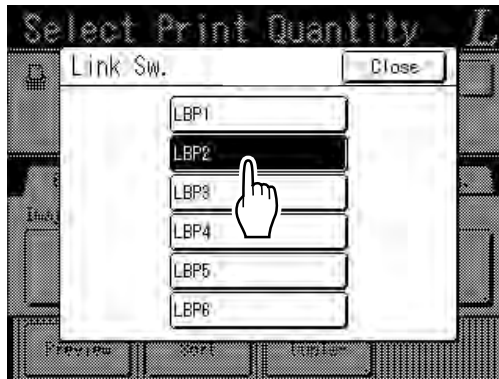

Note:

- If a Linked Printer is experiencing an error, that device is not available to be selected.
- If an error occurs on the selected Linked Printer while in Link Mode, the Link Sw. screen opens. Reselect another Linked Printer currently available for printing. For information on purchasing additional Linked Printers, contact your dealer (or authorized service representative).

Using Optional Functions on a Linked Printer

Steps for setting up optional functions are shown below. These are available when the Linked Printer has an optional device such as a sorter or a duplex unit installed.

Note:

- See Linked Printer User's Guide for further details on each function.

1 Touch [Functions] in the Link Basic Screen.

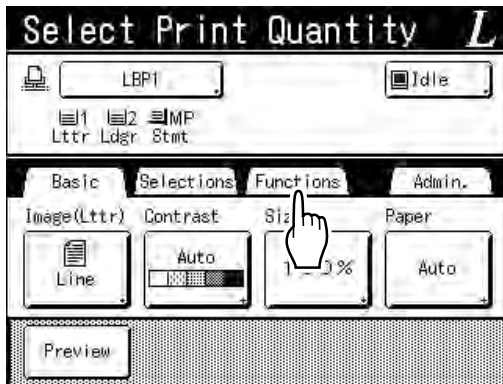

2 Select a function to modify.

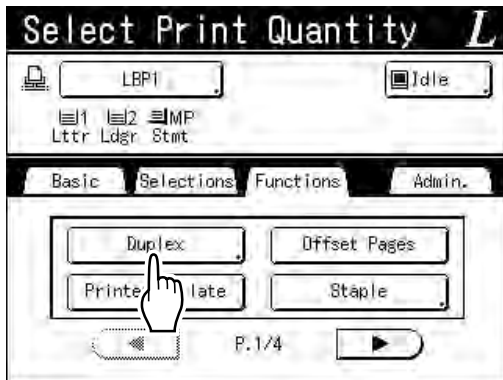



3 Make changes as needed.

See "Configurable Functions" (p.232) to select correct settings.

Configurable Functions

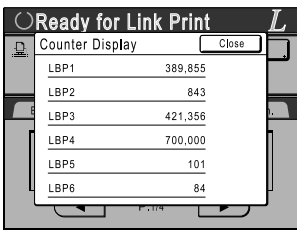
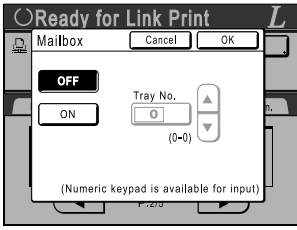
==: Initial setting (factory default)

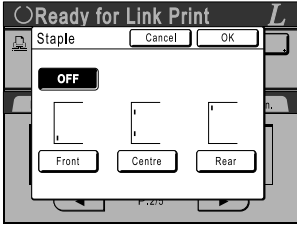
Functions	Description	Screens and Steps	Related Admin. Settings
Counter Display Displays the number of printed copies for each Linked Printer recognized by the machine.	---		---
Mailbox Select a paper receiving tray as an Output Tray.	Tray No. 0 to n (n is the total number of trays set on [Total Trays] on the Admin. screen.)	 <p>Touch   or enter using the Print Quantity Keys.</p>	Total Trays: The total number of trays. Set at 1 or more.
Offset Pages Enable a feature to alternately eject multiple-page print copies.	ON/OFF	---	Offset Pages: Available only when "Offset Pages" option is ON.
Staple Specify the positioning of staples on printed copies.	Differs depending on how the [Staple Position] is set on the Admin. screen. <ul style="list-style-type: none"> When set to [Invariable]: <u>ON/OFF</u> When set to [Variable]: <u>OFF</u> /Front/Center/<u>Rear</u> 	 <p>Touch to select a button.</p>	Staple: Available only when "Staple" option is ON.
Punch Select whether to punch holes on the printed copies.	ON/OFF	---	Punch: Available only when "Punch" option is ON.
Output Reversal Sets a function to print in reverse order the originals were scanned from the ADF unit.	ON/OFF	---	Output Reversal: Available only when "Output Reversal" option is ON.

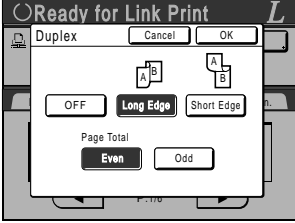
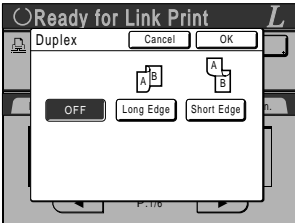
Functions	Description	Screens and Steps	Related Admin. Settings
<p>Printer Collate Select to retain original page order of the multi-page prints while ejecting into a single tray.</p>	<p>ON/OFF</p>	<p>---</p>	<p>Printer Collate: Available only when "Printer Collate" option is ON.</p>
<p>Duplex Print on both sides of the paper. Different screens and steps apply depending on whether or not the machine is equipped with the optional Auto Document Feeder AF-VI:II unit or Auto Document Feeder DX-1 unit.</p> <p>Note:</p> <ul style="list-style-type: none"> For instructions on how to print double-sided, See "Duplex Printing" (p.235). 	<ul style="list-style-type: none"> When the Auto Document Feeder AF-VI:II is installed <u>OFF/Long Edge/Short Edge</u> Page Total: <u>Odd/Even</u> When the Auto Document Feeder AF-VI:II is not installed <u>OFF/Long Edge/Short Edge</u> 	<ul style="list-style-type: none"> When the Auto Document Feeder AF-VI:II is installed  <p>Touch to select a button.</p> <ul style="list-style-type: none"> When the Auto Document Feeder AF-VI:II is not installed 	<p>---</p>

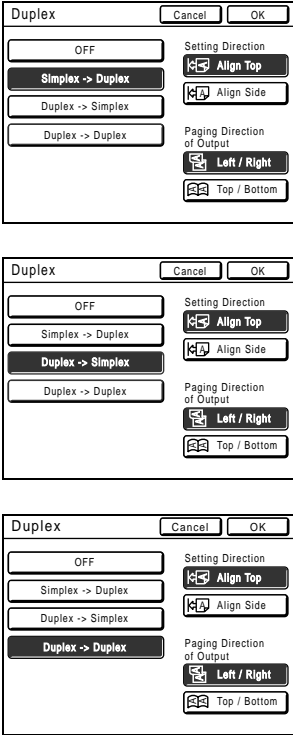
Functions	Description	Screens and Steps	Related Admin. Settings
<p>(Duplex)</p>	<ul style="list-style-type: none"> When Auto Document Feeder DX-1 is installed OFF Simplex -> Duplex/ Duplex -> Simplex/ Duplex -> Duplex <p>Setting Direction: Align Top, Align Side</p> <p>Paging Direction: Left / Right, Top / Bottom</p>	<ul style="list-style-type: none"> When the Auto Document Feeder DX-1 unit is installed  <p>Touch to select a button.</p>	<p>---</p>

Important!:

- Some optional functions may not be enabled concurrently, depending on the model and option configuration of the Linked Printer.

Duplex Printing

[Duplex]

Double-sided printing is possible when a Duplex Unit (Option) is installed to a Linked Printer. If the machine is not equipped with the Auto Document Feeder or the machine is equipped with the Auto Document Feeder AF-VI:II, see “Using the Stage Glass or Auto Document Feeder AF-VI:II” below. Refer to p.238 for when the unit has the Auto Document Feeder DX-1.

Note:

- The “Duplex” settings can be made from either Master Making or Print Functions screens. Linked Printer will print following the specifics set via either of these screens.

Using the Stage Glass or Auto Document Feeder AF-VI:II

This setting is available when a connected Linked Printer is equipped with the optional duplex printing unit.

1 Touch [Duplex] on the Functions screen.

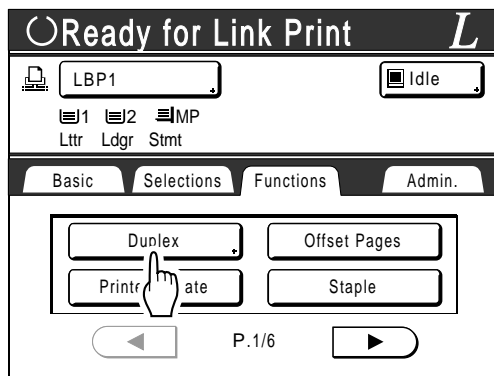

2 Set duplex binding direction.

Set the binding direction as shown below. The combination of scanning orientation and binding direction will result in different styles.

Scanning orientations and duplex binding directions

Original Orientation	Vertical (Portrait)	Horizontal (Landscape)
Binding Direction		
Long Edge		
Short Edge		

3 Select the number of originals.

When scanning an original from the ADF unit (option), select either **[Even]** or **[Odd]** numbers to match the number of original sheets.

Important!:

- This step is not necessary unless using the ADF unit. Continue on to step 4.

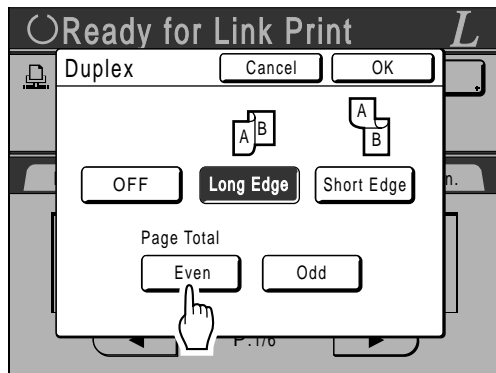

4 Touch [OK].

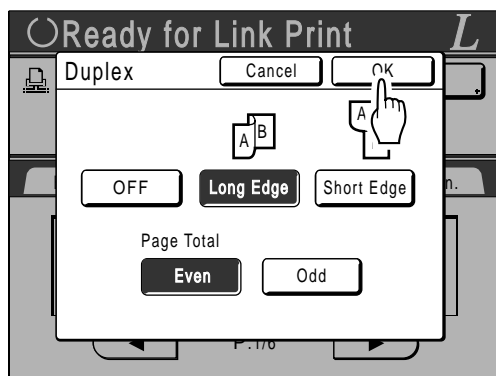

Note:

- To cancel Duplex Printing, touch [OFF] then [OK].

5 Place the original.

Note:

- For information about placing the original, see step 5 in "2-Color Printing with 2 Originals". (p.41)
- To scan a single sheet of an original, place it on the Stage Glass.
- When Duplex Printing from odd number of originals scanned in the ADF unit, the reverse side of the last page will be blank.

6 Select Print functions as needed.

The following functions are available:

- Image Processing mode (p.70)
- Scanning Contrast (p.74)
- Size (p.78)
- Dot Process (p.72)
- Memory (p.150)
- Contrast Adj (p.74)
- Tone Curve (p.75)
- Book Shadow (p.84)
- Top Margin (p.105)
- Preview (p.109)
- Overlay (p.208)
- Storage Memory (p.204)

7 Enter the number of copies using the Print Quantity Keys.

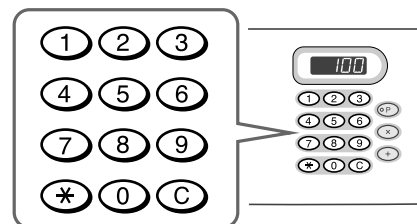

The number is displayed on the Print Quantity Display.

Note:

- To change the number, press the **C** key, then re-enter the correct number.

8 Press the **START key.**

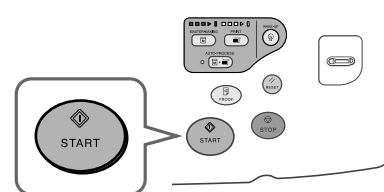

The next steps are different, depending on whether the original is scanned from Stage Glass, or from the ADF unit.

Perform one of the following steps:

Important!:

- Either Stage Glass or ADF unit may be used, but not both at a time.

◆ Using the Stage Glass

Place the first original document on the Stage Glass, wait for the message “Duplex Processing for Linked Printer” to disappear, then place the second original and press the  key.

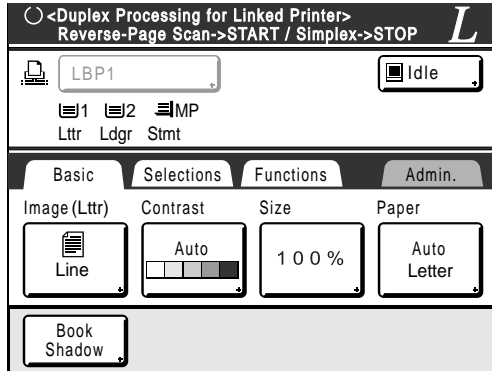

Once data for both sides of the paper is transmitted, the Linked Printer will print the specified number of copies.

To print multiple Duplex Print copies, repeat steps 5-8 of Duplex Printing.

Important!:

- Once the first original is scanned, the next original must be placed within pre-determined Duplex Interval period on the Admin. screen (☞p.178). Failure to do so will result in the Linked Printer printing one side only.

Note:

- Pressing the  key without placing the second original will also result in the Linked Printer printing one side only.
- Setting adjustment can be made on the following functions after placing the second original and before its scan starts:
 - Image Processing mode (☞p.70)
 - Scanning Contrast (☞p.74)
 - Size (☞p.78)
 - Dot Process (☞p.72)
 - Contrast Adj (☞p.74)
 - Tone Curve (☞p.75)

◆ Using the ADF unit

The top sheet is scanned first.
As each original page is scanned, the Linked Printer prints specified number of copies.

When Equipped with the Auto Document Feeder DX-1

Duplex originals can be scanned when the machine is equipped with the optional Auto Document Feeder DX-1.

Setting/Paging Direction of the Original and Resulting Output

Setting Direction: Direction of the original when set as seen from the front of the machine.

Paging Direction: Binding direction of the original (or output)

Button icons on the screen indicate the direction in which the original is set.

◆ Simplex -> Duplex (when a connected Linked Printer is equipped with the optional duplex printing unit)

Select this setting to print simplex originals on both sides of output paper.

Place the original face-up in the Auto Document Feeder DX-1.

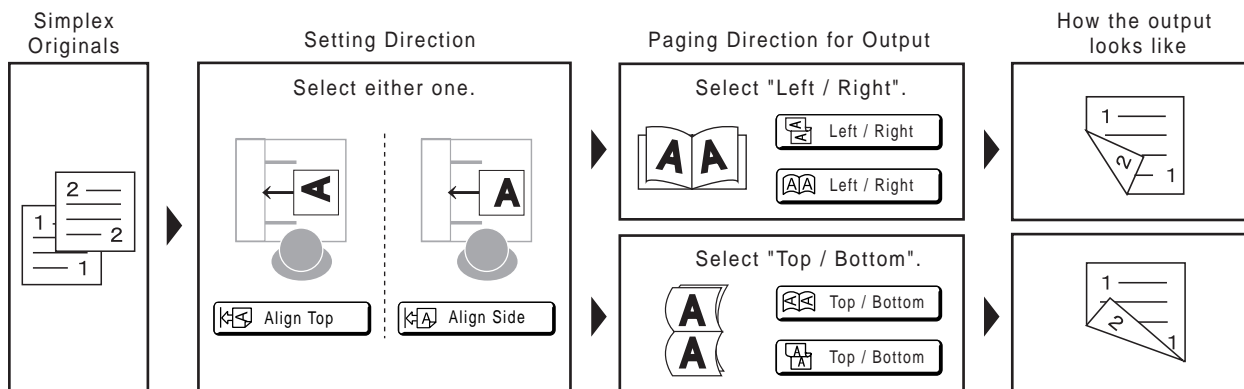

◆ Duplex -> Duplex (when a connected Linked Printer is equipped with the optional duplex printing unit)

Select this setting to print duplex originals on both sides of output paper.

If the machine is equipped with the optional Auto Document Feeder DX-1, originals are scanned in the following order: front of original 1 → reverse of original 1 → front of original 2 → reverse of original 2, etc.

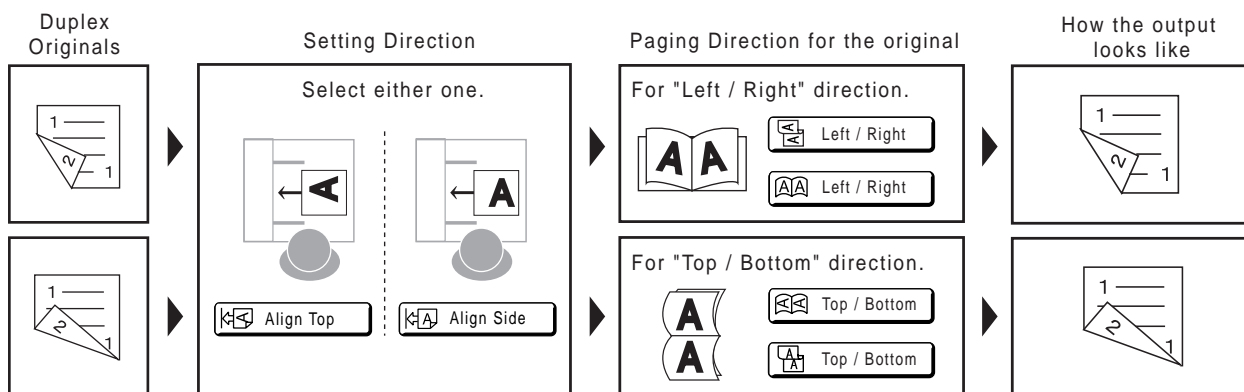

1 Touch [Duplex] on the Functions screen.

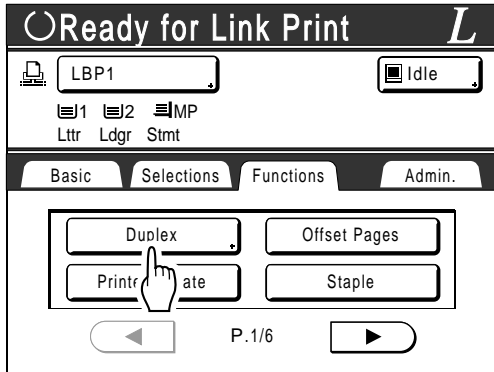

2 Touch [Simplex -> Duplex], [Duplex -> Simplex] or [Duplex -> Duplex].

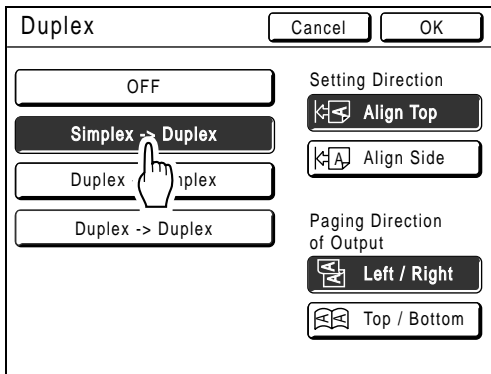

3 Set "Setting Direction" and "Paging Direction".

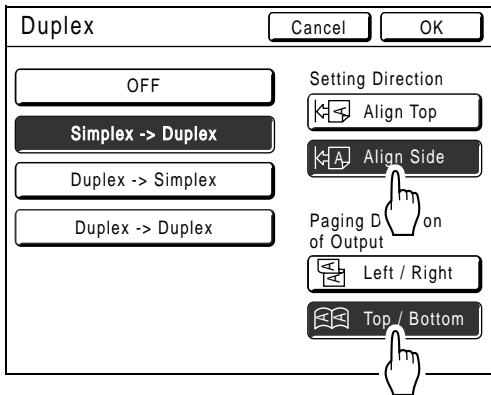

4 Touch [OK].

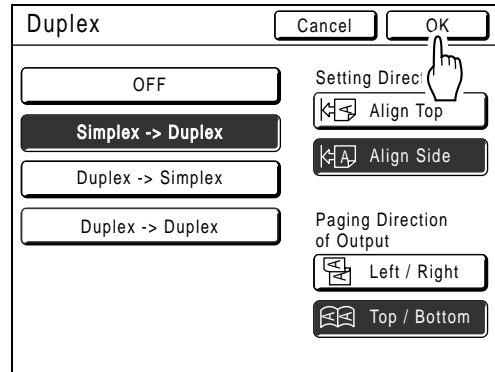

Note:

- If you do not require duplex printing, touch [OFF] and then [OK].

5 Place the original.

Place the original on Stage Glass or in the Auto Document Feeder DX-1. For information about placing the original, see step 5 in "2-Color Printing with 2 Originals" (p.41).

6 Select Print functions as needed.

The following functions are available:

- Image Processing mode (p.70)
- Scanning Contrast (p.74)
- Size (p.78)
- Dot Process (p.72)
- Memory (p.150)
- Contrast Adj (p.74)
- Tone Curve (p.75)
- Book Shadow (p.84)
- Preview (p.109)
- Overlay (p.208)

7 Enter the number of copies using the Print Quantity Keys.

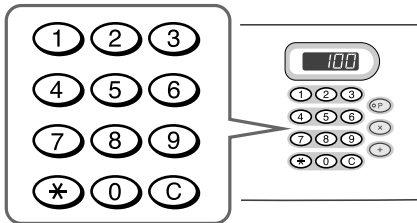

The number is displayed on the Print Quantity Display.

Note:

- To change the number, press the **C** key, then re-enter the correct number.

8 Press the **START** key.

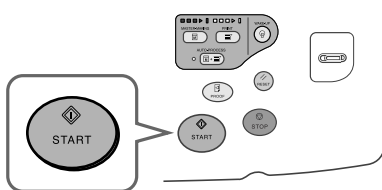

Subsequent procedures will be different depending on whether you place the original on the Stage Glass or in the Auto Document Feeder DX-1. Follow the processes below suitable for each case.

Important!:

- You cannot use both the Stage Glass and the Auto Document Feeder DX-1 at the same time to scan the original.

◆ Setting the original on the Stage Glass

Place the first original document on the Stage Glass, wait for the message “Duplex Processing for Linked Printer” to disappear, then place the second original and press the **START** key.

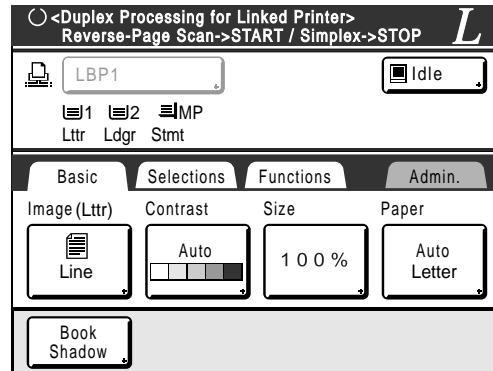

Once data for both sides of the paper is transmitted, the Linked Printer will print the specified number of copies.

To print multiple Duplex Print copies, repeat steps 5-8 of Duplex Printing.

Important!:

- Once the first original is scanned, the next original must be placed within pre-determined Duplex Interval period on the Admin. screen (p.178). Failure to do so will result in the Linked Printer printing one side only.

Note:

- Pressing the **STOP** key without placing the second original will also result in the Linked Printer printing one side only.
- Setting adjustment can be made on the following functions after placing the second original and before its scan starts:
 - Image Processing mode (p.70)
 - Scanning Density (p.74)
 - Size (p.78)
 - Dot Process (p.72)
 - Contrast Adj (p.74)
 - Tone Curve (p.75)

◆ Using the Auto Document Feeder DX-1

The top sheet is scanned first.

As each original page is scanned, the Linked Printer prints specified number of copies.

Tip:

Printing duplex originals on one side of paper

If the machine is equipped with the optional Auto Document Feeder DX-1, both sides of an original duplex document can be printed on one side of the output paper.

Set **[Duplex -> Simplex]** on the Duplex screen for printing.

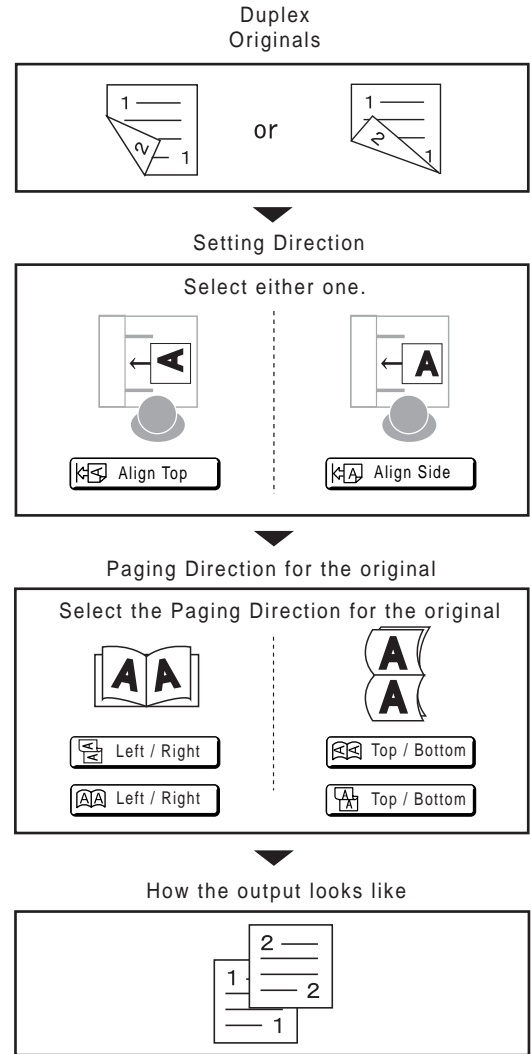
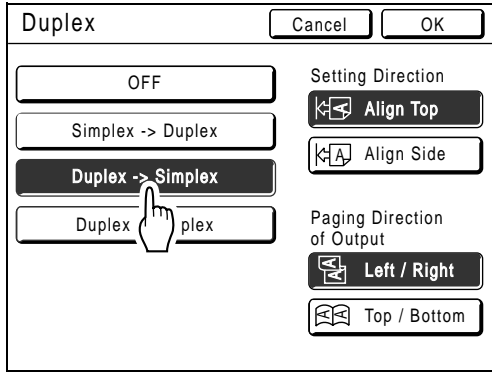

Replacing Consumables

Check for Remaining Amount of Consumables

The machine checks and reports on remaining amount of ink, master, as well as the space left in the disposal box.

Note:

- The report may not be displayed if detection fails.
- The reported amount is for reference only and may not be perfectly accurate.

1 Touch [i Info] on the Basic Screen.

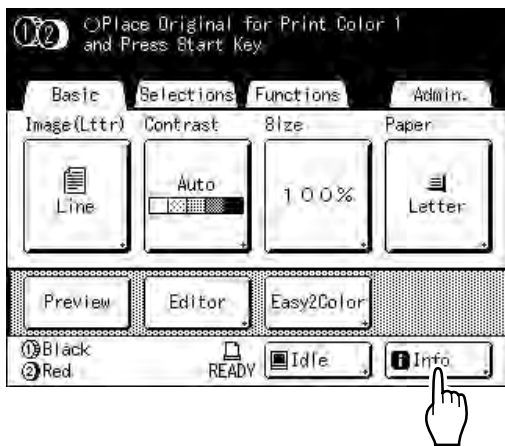

2 Check for remaining amount of consumables.

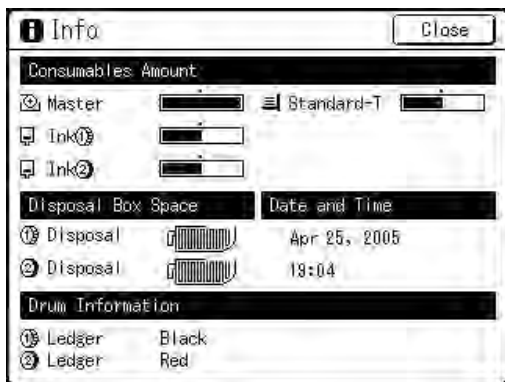

When running low, be sure to restock supply.

- Master (p.243)
- Ink (p.246)
- Master Disposal (used master) (p.248)

Display Details

Indicator/Message	Description
	The black bar indicates the remaining amount. Ex: approximately 10% left
(Unknown), ---, no display	Indicates that consumable data is not available, is not set, etc.

Tip:

i Information Button

i icon on the **i** Information Button displays current status of the consumables as detected by the machine.

The **i** icon will change depending on the matching information detected from the consumable.

- When matching information was correctly retrieved from the consumable **i** (normal display)
- When matching information is not available **i** (gray display)

When the **i** icon is grayed, the remaining amount of master/ink cannot be displayed.

When the master material or ink runs low, (master) or (ink) icon blinks on the right of the button to let you know that the item should soon be replaced.

Note:

- If the machine is unable to retrieve matching data from the consumable, you must enter the correct setting value.
p.279

Replacing the Master Roll

When the Master Roll is depleted, a message is displayed and the machine stops. Replace with a new Master Roll.

Important!:

- For the Master Roll, it is recommended to use the products specified by RISO.
- Keep the power ON while replacing the master.

1 Check the indicator of the Master Making Unit Release Button is ON.

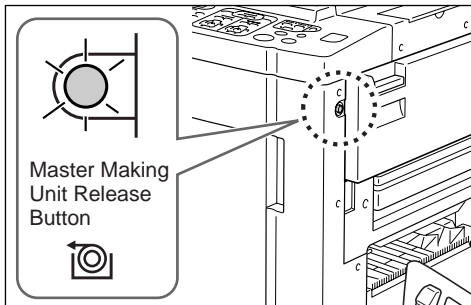

If the indicator is off, press the Master Making Unit Release Button to turn it on.

Important!:

- While the Print Cylinder (Drum) is pulled out, Master Making Unit cannot be pulled out. Return the Print Cylinder (Drum) into position and press the Master Making Unit Release Button.
- Return the Print Cylinder (Drum) into position and press the Master Making Unit Release Button.

☞ p.250

2 Open the Master Making Unit Removal Cover.

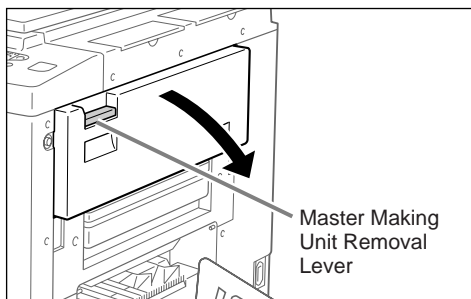

Grasp the Master Making Unit Removal Lever and pull out to open.

3 Pull out the Master Making Unit.

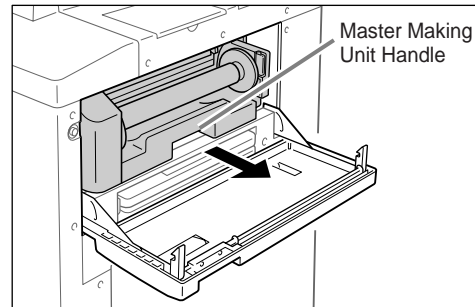

Grasp the Master Making Unit Handle and pull forward.

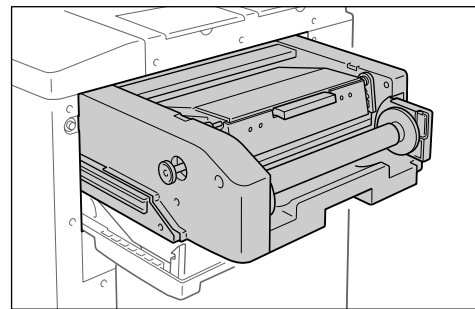

Pull out slowly until it stops.

4 Open the Master Making Unit Cover.

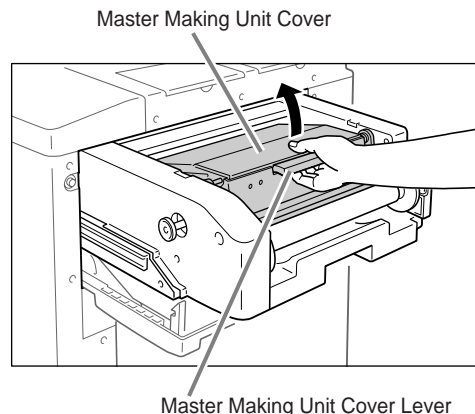

Grasp the Master Making Unit Cover Lever and open the Master Making Unit Cover.

5 Open the Master Roll Holder.

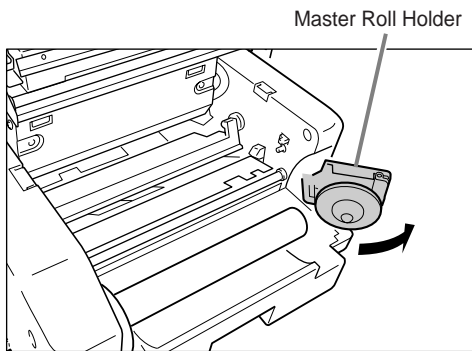

6 Remove the depleted Master core.

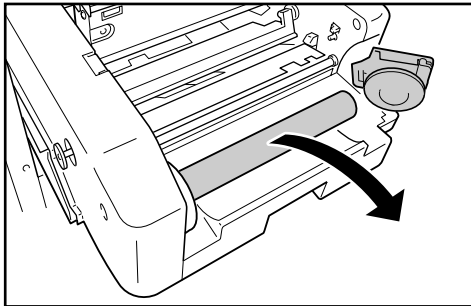

Note:

- Dispose the depleted master core according to the disposal rule of your local community. p.253

7 Install a new Master Roll.

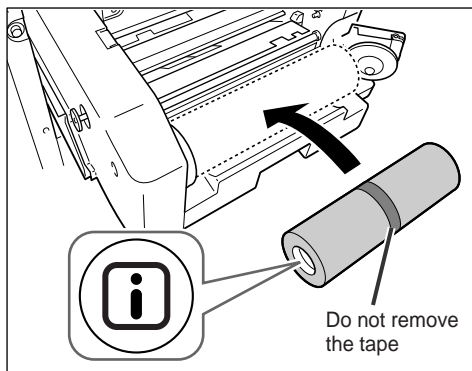

Remove the plastic shrink wrap from the new Master Roll, and place in with the **i** mark to the left.

Important!:

- Take care not to damage the **i** section when removing the shrink wrap. If the **i** section is bent or the perforation cut, the master will become unusable.
- Do not remove the tape yet.

8 Close the Master Roll Holder.

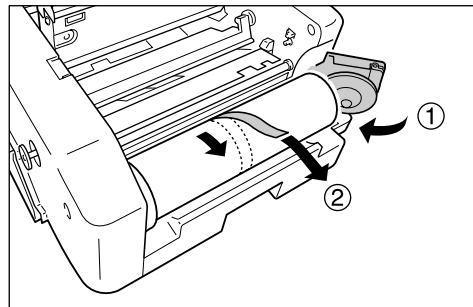

Remove the tape once the Master Roll Holder has been closed.

9 Insert the leading edge of the master under the Master Guide Flap.

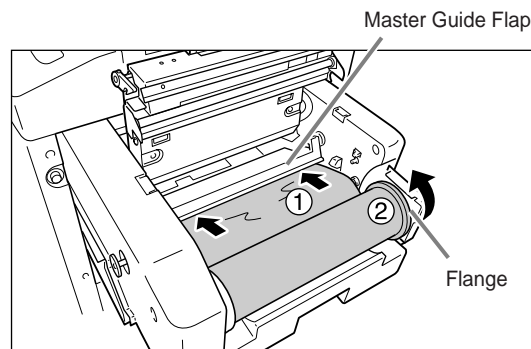

Insert the leading edge of the master into its entrance under the Master Guide Flap and advance it as far in as it will go (①). If the Master is loose, turn the flange at the right towards the rear and rewind (②).

Tip:

If You Cannot Insert the Master

Insert the leading edge of the Master using the following steps.

- 1) **Raise the Master Guide Flap**
Turn the dial on the edge of the Master Guide Flap towards the rear and raise the Master Guide Flap.
- 2) **Pull out the master to the line indicated by the arrow.**
- 3) **Lower the Master Guide Flap.**

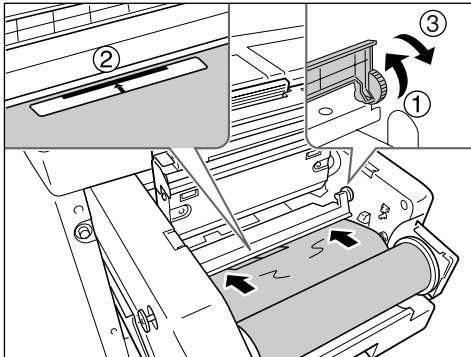

10 Return each part to its original position.

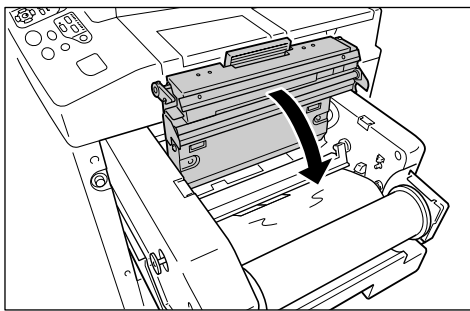

Close the Master Making Unit Cover.

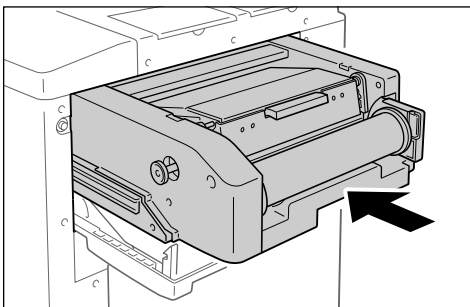

Slowly return the Master Making Unit to the position where a beep sounds.

11 Close the Master Making Unit Removal Cover.

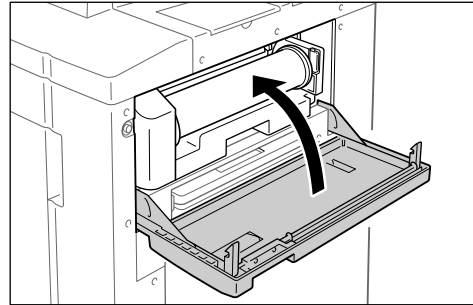

Replacing the Ink Cartridge

When the ink is depleted, a message is displayed and the machine stops. Replace with a new Ink Cartridge.

⚠ Caution:

- Ink may be left on the area around the Print Cylinder (Drum), so take care not to smudge your hands or clothes.
- Wash immediately with soap if you should get ink on your hands, etc.

Important!:

- For the Ink Cartridge, it is recommended to use the products specified by RISO.
- Keep the power ON while replacing the Ink Cartridge.
- Replace with an Ink Cartridge of the same ink color. If you want to change the ink color, replace the Print Cylinder (Drum) itself.
☞ p.250

1 Open the Front Cover.

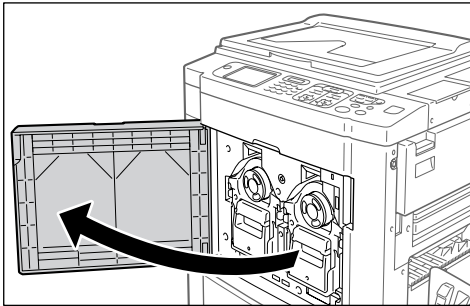

2 Pull the empty Ink Cartridge out of the holder.

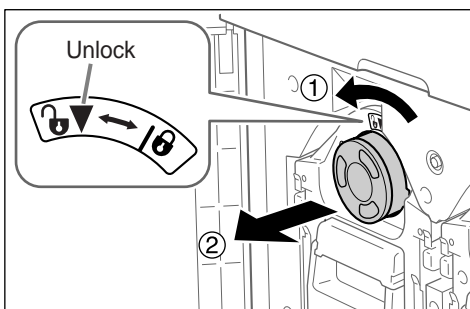

Turn the Ink Cartridge to the counter clockwise (🔒) and then pull it out.

Note:

- Dispose the empty Ink Cartridge according to the disposal rule of your local community.

3 Remove the cap on the new Ink Cartridge.

Turn the Ink Cartridge cap to remove.

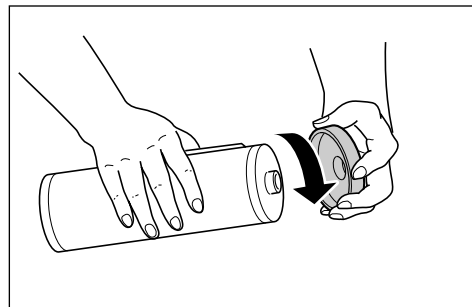

Important!:

- Do not touch or give impact to the outlet surface of the new Ink Cartridge. Do not peel off the label beside the Ink Cartridge opening.

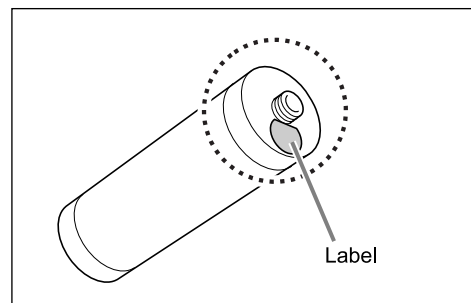

Note:

- You can store the ink cartridge cap on the right side of the stage glass.

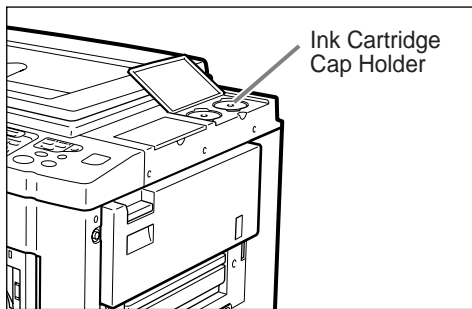

4 Insert the new Ink Cartridge.

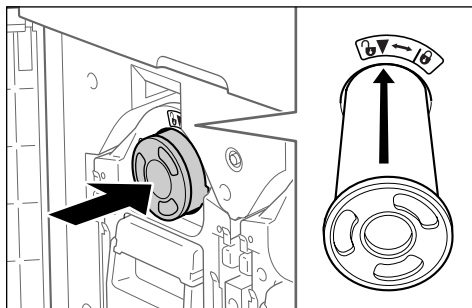

Align the arrow on the Ink Cartridge to the ▼ mark on the cylinder (drum) unit, and insert until it stops.

5 Lock the Ink Cartridge.

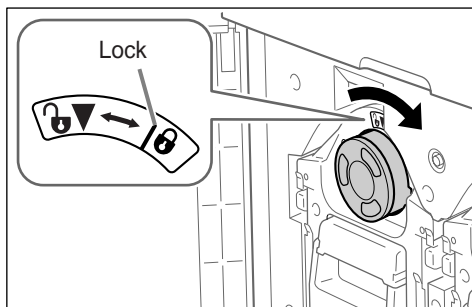

Turn the Ink Cartridge clockwise (↻) and lock in position.

6 Close the Front Cover.

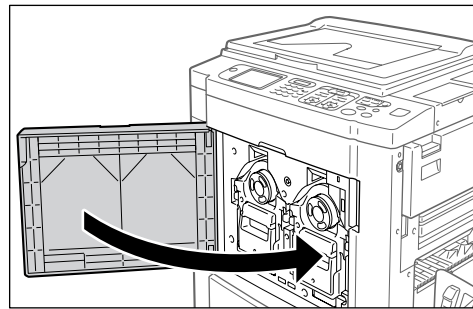

Emptying the Master Disposal Box

Used masters are held in the Master Disposal Box. When the Master Disposal Box is full, a message displays and the machine stops. Discard the used masters.

⚠ Caution:

- Wash immediately with soap if you should get ink on your hands, etc.

Important!:

- The Master Disposal Box can be padlocked to prevent the information contained in the discarded master from being leaked. If the Master Disposal Box is safely protected by the padlock, be sure to contact the administrator before discarding the master.
- When “Protect” is ON, you can remove the Master Disposal Box only when the messages such as “Master Disposal Box is Full” or “Master Jammed in Disposal Unit” are displayed [p.191](#)

This machine has two master disposal boxes, one for Cylinder (Drum) 1 and one for Cylinder (Drum) 2. The procedures are same for both. The master disposal box for Cylinder (Drum) 1 is explained here.

1 Remove the Master Disposal Box.

If the Master Disposal Box lever is locked, slide the lever to the right to unlock.

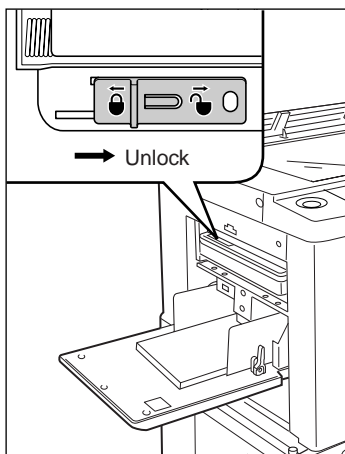

Grasp the Master Disposal Box handle and pull the box forward.

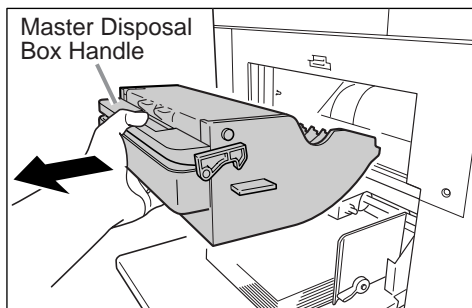

Important!:

- If the Master Disposal Box is padlocked, contact the administrator to undo the padlock.

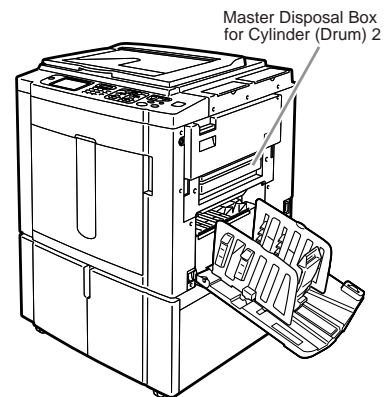
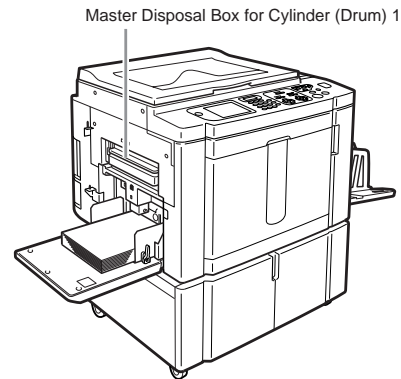

2 Discard the ejected masters.

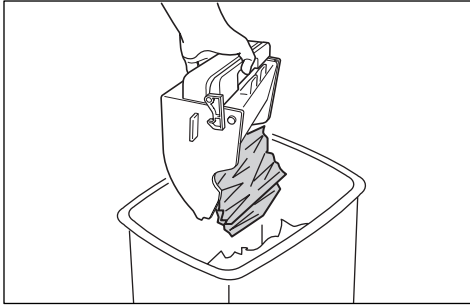

Tilt the Master Disposal Box down and discard the used masters.

Note:

- Dispose the ejected masters according to the disposal rule of your local community.
☞ p.253
- If used masters get stuck, hold the Master Disposal Box tilted downward and squeeze the push-out lever to release any remaining masters.

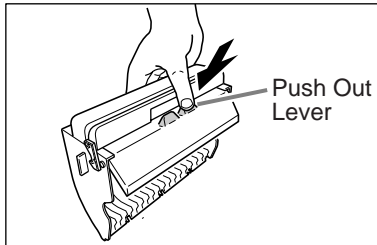

3 Place the Master Disposal Box into position.

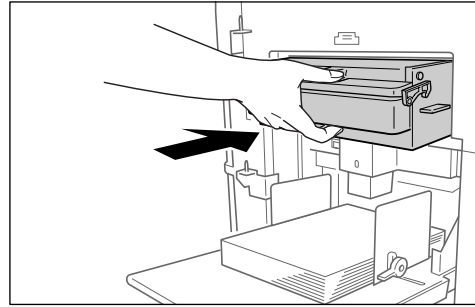

Insert the Master Disposal Box until it stops.

Note:

- If necessary, slide the lever to the left to lock the Master Disposal Box and add a padlock for extra security.
☞ p.190

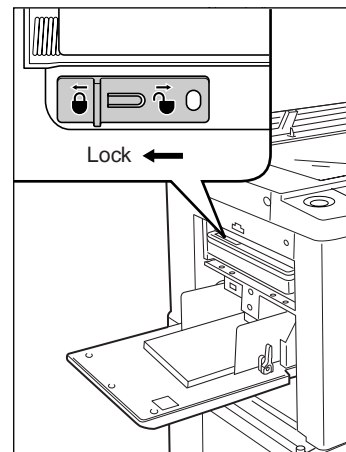

Replacing the Print Cylinder (Drum)

When replacing with a Color Cylinder (Drum) to change colors, or when removing jammed paper, follow the steps to remove Print Cylinder (Drum). Be sure to use a Color Cylinder (Drum) specifically designed and approved for use with this machine.

⚠ Caution:

- Do not stand the Print Cylinder (Drum) upright. Doing so may stain the floor, etc.

Important!:

- Use only Print Cylinders (Drums) specifically designed and approved for use with this machine.
- Keep the power ON while removing or replacing the Print Cylinder (Drum).
- Make sure to place the changed Print Cylinder (Drum) into the cylinder (drum) case and store horizontally.

Removing the Print Cylinder (Drum)

Note:

- The cylinder (drum) is removed from the printer to be changed, and to remove paper jams.

The procedure for changing Cylinder (Drum) 1 and Cylinder (Drum) 2 is the same. The procedure for changing Cylinder (Drum) 1 is explained here.

1 Open the Front Cover.

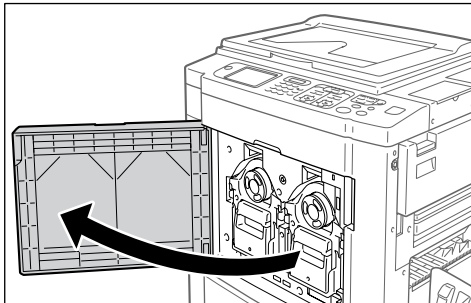

2 Check that the indicator of the Print Cylinder (Drum) Release Button is ON.

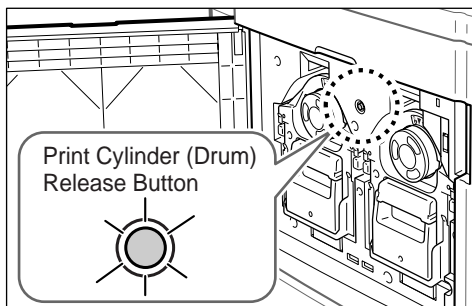

If the indicator is off, press the Print Cylinder (Drum) Release Button to turn it on.

Important!:

- When the Master Making Unit is out, the Print Cylinder (Drum) cannot be pulled out. Return the Master Making Unit into position and press the Print Cylinder (Drum) Release button.
☞ p.243

Note:

- Only one of the cylinders (drums) may be slightly forward, but both cylinders (drums) can be removed.

3 Pull out the Print Cylinder (Drum).

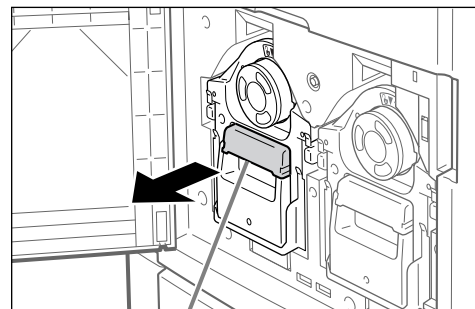

Cylinder (Drum) Handle

Grasp the Print Cylinder (Drum) Handle and slowly pull until the Print Cylinder (Drum) is completely extended.

4 Remove the Print Cylinder (Drum).

Firmly grasp the Green Handle

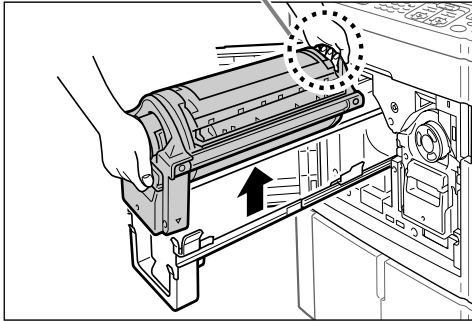

Use both hands to lift the Print Cylinder (Drum) straight up to remove from the rail. Proceed with replacing the cylinder (drum), removing the paper jam, etc..

⚠ Caution:

- Do not touch the connector on the Print Cylinder (Drum). Neglecting this may result in malfunction of the Print Cylinder (Drum) because of static electricity or other factors.

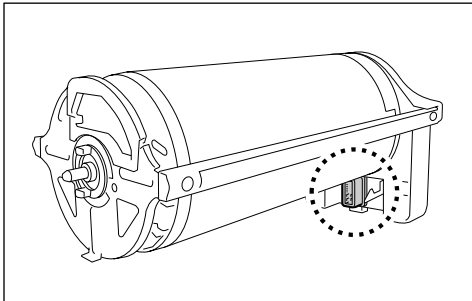

Installing the Print Cylinder (Drum)

1 Place the Print Cylinder (Drum) on the Rail.

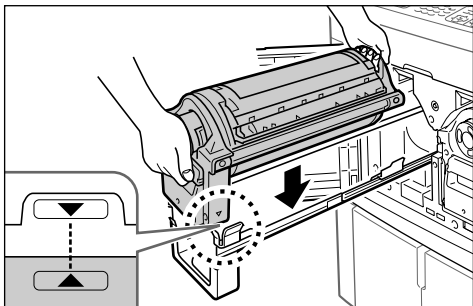

Align the ▼ mark on the Print Cylinder (Drum) with the ▲ mark on the guide, and place the Print Cylinder (Drum) horizontally onto the guide.

Note:

- If the Print Cylinder (Drum) was manually rotated, be sure to turn it back so that ► and ◀ marks align, after it is placed on the guide.

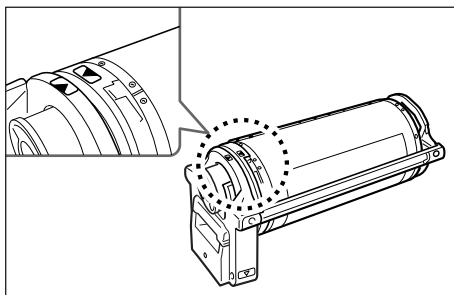

2 Return the Print Cylinder (Drum) to its original position.

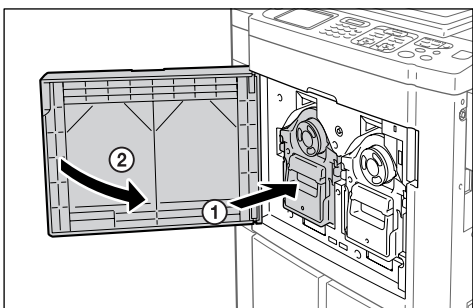

Push the Print Cylinder (Drum) in as far as it will go, and then close the Front Cover.

Important!:

- Do not grasp the Print Cylinder (Drum) Handle when pushing in the Print Cylinder (Drum).

Disposal of Depleted Consumables

Dispose of depleted Ink Cartridges, Master cores, ejected masters according to the regulations in your local community.

If required, separate the specific components using the following procedures to dispose them properly.

◆ Ink Cartridge

Remove the label (metal included) at the arrow from the outlet surface of the Ink Cartridge, and then dispose them separately.

Because ink may have adhered to the outlet surface of the Ink Cartridge, be careful not to smudge your clothes.

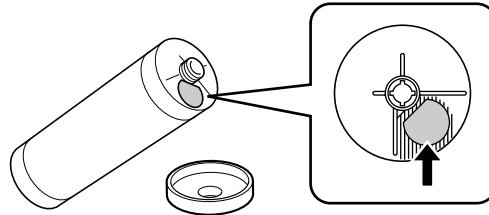

Parts	Materials
Ink Cartridge material	plastic (polypropylene/polyethylene)
Label material	plastic (metal included)
Ink	Soy oil, petroleum hydrocarbons, water, pigments

◆ Master core

A metallic component has been attached to the bottom of the end section having the  mark stamped.

Because the component section has been perforated for cutout convenience, tear along the perforation for proper disposal.

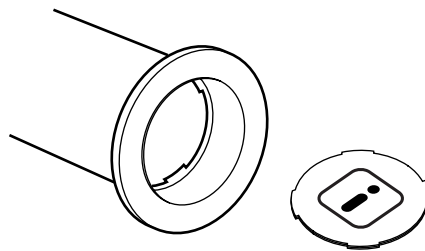

Parts	Materials
Core material	Paper
Master material	plastic, Japanese paper
Material of the cutout component	plastic (metal included) and paper

◆ Ejected Master

Parts	Materials
Master material	plastic, Japanese paper
Ink material	Soy oil, petroleum hydrocarbons, water, pigments

Note:

- It is made of carbon and hydrogen compounds. If fully combusted, it will turn into water and carbon dioxide.



Maintenance

Cleaning

The print quality may suffer if parts such as Thermal Print Head of the Master Making Unit, Scanner Glass of the ADF unit (option), White Roller, etc. are contaminated with dust, dirt, ink, white-out, etc..

Follow the steps below for periodic cleaning.

▲WARNING:

- Before cleaning any part of the machine, turn off the power.
- Do not remove any fixed covers.
- Contact your service representative immediately if you suspect any dangerous situations or have questions or problems with the machine.
- Contact your service representative before moving the machine.
- Do not allow unauthorized persons to make adjustments or repairs.

▲Caution:

- The machine has precision moving parts inside. Do not handle the machine in any other way than described in this manual.
- Be careful of the edge of metal parts, otherwise it may cause an injury.
- Do not make any modifications to the machine or remove any parts.
- Neither RISO nor its dealer is responsible for maintenance service performed by non-RISO-authorized personnel.

Thermal Print Head

Clean the Thermal Print Head each time you replace the Master Roll.

Open the Master Making Unit Cover, and gently wipe the Thermal Print Head in the back of the unit several times with a soft cloth or tissue.

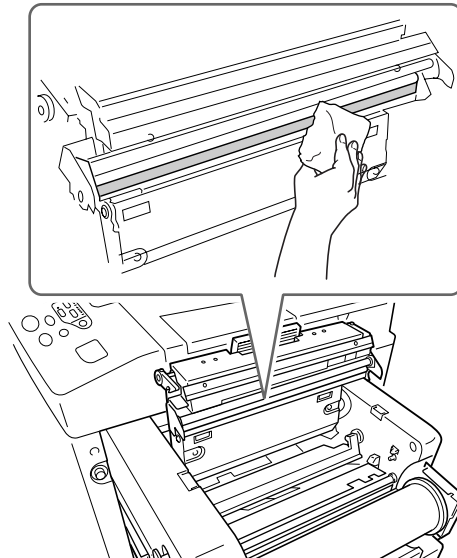

⚠ Caution:

- Since the Thermal Print Head is very delicate, avoid shocks or scratches with a hard object.
- Since Thermal Print Head is susceptible to (damage by) static electricity, please be sure to remove the static electricity charged in the body before cleaning.

Stage Glass and Stage Cover Pad

If the Stage Glass and/or Stage Cover Pad is stained, gently wipe them with a soft cloth or tissue.

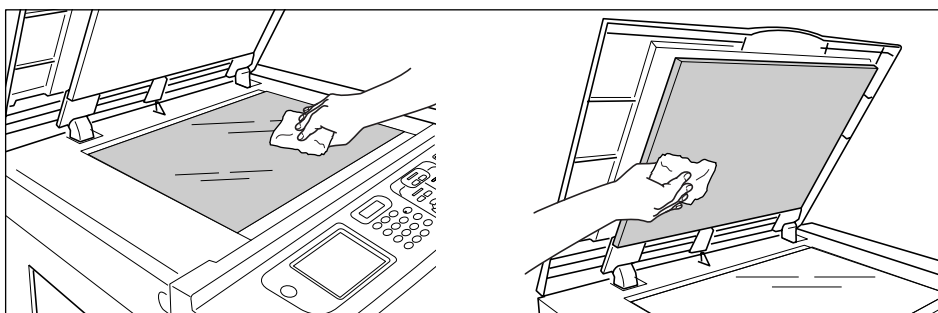

⚠ Caution:

- Since the Stage Glass is very delicate, avoid shocks or scratches with a hard object.

Scanner Glass and White Sheet of ADF unit (Option)

Gently wipe the Scanner Glass, and the White Sheet several times with a soft cloth or tissue.

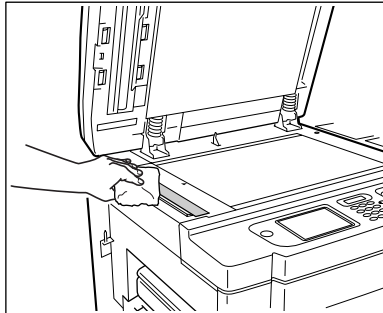

◆ For the Auto Document Feeder AF-VI

Clean while rotating the white roller.

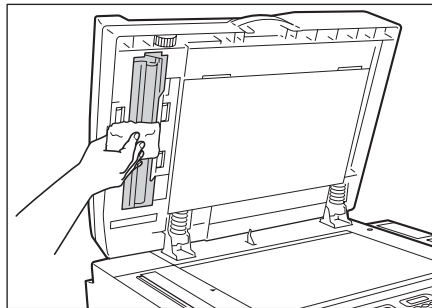

◆ For the Auto Document Feeder DX-1

The white Sheet does not rotate.

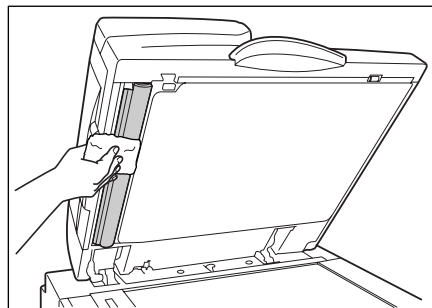

⚠ Caution:

- Since the Stage Glass is very delicate, avoid shocks or scratches with a hard object.

Pressure Roller

If the Pressure Roller, which presses print paper against the Print Cylinder (Drum), is stained, smudged strips may appear on the back of copies.

If this happens, gently wipe the Pressure Roller with a soft cloth dampened with alcohol.

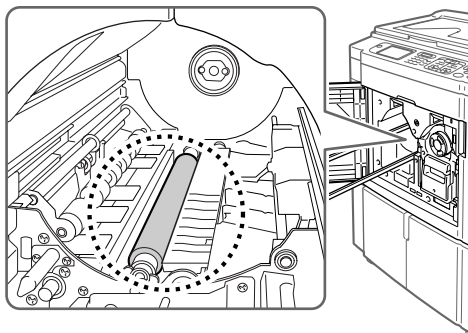

⚠ Caution:

- Be sure to turn OFF power to the machine when cleaning the Pressure Roller.
- When putting your hand into the unit, do not touch the paper separation hook. The sharp tip of the hook can hurt your hand.
- Ink may be left on the area near the Print Cylinder (Drum), so take care not to smudge your hands or clothes. Wash immediately with soap if you should get ink on your hands, etc.

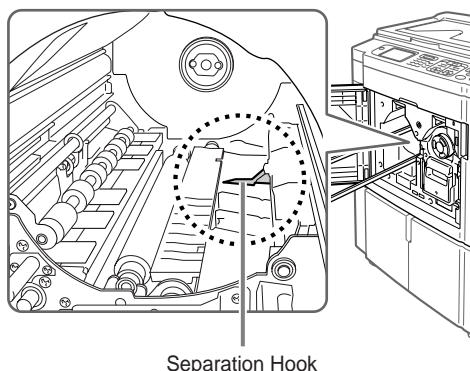

Separation Hook

The Exterior

Use a soft cloth to gently wipe down the entire printer on a regular basis in order to prevent the exterior from getting dirty.

If using a cleaning agent, use one recommended by your authorized service representative.

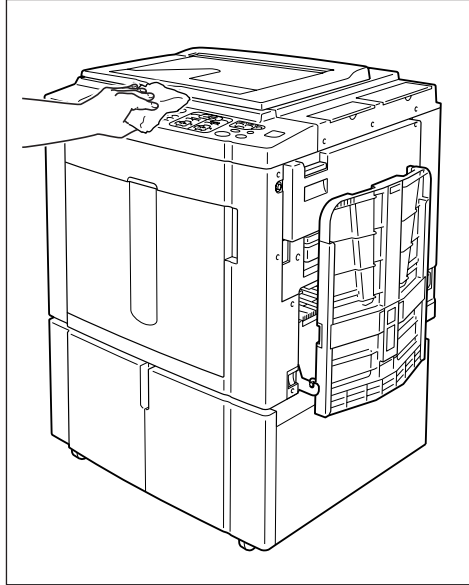

⚠ Caution:

- Because the machine exterior is plastic, never use alcohol or solvent when cleaning.
- The Display may be cleaned by gently wiping with a dry cloth. Dampen a cloth with a small amount of cleaner and gently wipe to remove any ink.
Do not spray or pour cleaner solution directly onto the display. Doing so can cause damage.

Troubleshooting

When a Message Displays

Refer to the following information to determine the cause and take appropriate actions when the machine stops operating and a message is displayed.

Error Message Layout

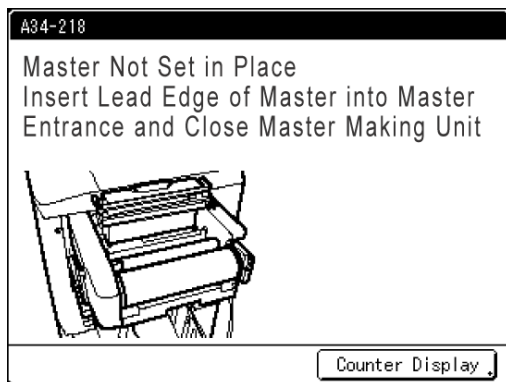

A message and a troubleshooting illustration will be displayed in accordance with the message type to show how to resolve the problem.





- 1) Error Number**
error type and error ID number
- 2) Error Messages**
description of the error and actions to resolve the problem
- 3) Graphic Area**
visually demonstrates how to resolve the problem
- 4) Counter Display**
Touch to display the “Counter Display” window

Error Number	Error Types	Description	Reference page
T00-000	Service Call Error	Errors that require repair or inspection by a authorized service representative. To resolve a Service Call Error, contact your dealer (or authorized service representative) with the error number.	p.263
A00-000	Jam Error	Displays when the master is jammed, etc..	p.263
B00-000	Optional Device Error	Displays when an error occurs on the optional device or Linked Printer.	p.264
C00-000	Consumable Error	Displays when a consumable such as ink or master roll is depleted.	p.266
D00-000	Installation Error	Displays when a part or unit is not properly installed.	p.266
J00-000	Paper Jam Error	Displays when an original document or printing paper is jammed.	p.269

T00-000:Service Call Error (in alphabetical order)

Message	Possible Cause	Action
!!Battery Replacement!! Call Service	The battery is low or depleted.	Contact your dealer (or authorized service representative) and have the battery replaced. Press the  key or the  key to clear the error message display.
!!System Error!! Press Reset Key If Recovery has Failed, Call Service	A system error has occurred.	Press the  key. If the problem persists, contact your dealer (or authorized service representative).
!!System Error!! Turn Main Power SW OFF Then ON If Recovery has Failed, Call Service		Shut off power, then restart. If the problem persists, contact your dealer (or authorized service representative).

A00-000:Paper Jam Errors (in alphabetical order)

Message	Possible Cause	Action
Master Disposal Error Pull Out Print Cylinder 1 and Discard Master	The master was not properly discarded.	1) Pull out the Print Cylinder (Drum) and remove the master from the cylinder (drum). If a master is not wrapped around the cylinder (drum), check the disposal unit and remove the master. ☞p.250 2) Return the Print Cylinder (Drum) in place. 3) Press the  key.
Master Disposal Error Pull Out Print Cylinder 2 and Discard Master		
Master Jammed in Disposal Unit Pull Out Master Disposal Box 1 and Remove Jammed Master	The master is jammed in the Master Disposal Unit.	Pull out the Master Disposal Box and remove the jammed master. If the masters are difficult to remove, pull out the cylinder (drum) and then remove. ☞p.248 ☞p.250 If the error persists, contact your dealer (or authorized service representative).
Master Jammed in Disposal Unit Pull Out Master Disposal Box 2 and Remove Jammed Master		
Master Loading Error Pull Out Print Cylinder 1 and Discard Master	The master did not properly attach to the Print Cylinder (Drum).	1) Pull out the Print Cylinder (Drum) and remove the master from the cylinder (drum). ☞p.250 2) Return the Print Cylinder (Drum) in place. 3) Pull out the Master Making Unit and reinstall the master. 4) Press the  key.
Master Loading Error Pull Out Print Cylinder 2 and Discard Master		

Message	Possible Cause	Action
Master Mis-Feed Pull Out Master Making Unit and Rewind Master Roll, then Reset Master in Place	The master is improperly installed.	Pull out the Master Making Unit, rewind the master and reinstall. ☞p.243 Important!: • If the leading edge of the master is wrinkled or torn, cut the edge straight and reinstall.
Master Not Set in Place Insert Lead Edge of Master into Master Entrance and Close Master Making Unit	The master is improperly installed or is missing.	Pull out the Master Making Unit and reinstall the master. ☞p.243 Important!: • If the leading edge of the master is wrinkled or torn, cut the edge straight and reinstall.
Master Remains on Print Cylinder 1 Pull Out Print Cylinder 1 and Remove Master	An unnecessary master remains on the Print Cylinder (Drum).	1) Pull out the Print Cylinder (Drum) and remove the master from the cylinder (drum). ☞p.250 2) Return the Print Cylinder (Drum) in place.
Master Remains on Print Cylinder 2 Pull Out Print Cylinder 2 and Remove Master		
Safety SW on Standard Feed Tray is Activated Reset paper on Standard Feed Tray	The safety switch for the Paper Feed Tray has been activated.	Check underneath the Paper Feed Tray and on top of the printing paper for any obstructions. Remove if any exist.
System Error in Master Making Unit Take Out Master and then Close Master Making Unit Cover	The cutter mechanism for the master malfunctioned.	1) Either remove the cylinder (drum) and the master on the cylinder (drum), or cut evenly and remove. 2) Pull out the Master Making Unit and remove the master. ☞p.243 3) Closing the Master Making Unit Cover will reset the error. Setup the master again.

B00-000:Optional Device Error (in alphabetical order)

Message	Possible Cause	Action
Data Transfer Error for Linked Printer Check Network and Linked Printer Then Transfer Data Again	Cannot transmit data to Linked Printer.	Check connections from Linked Printer and the machine to the hub. If they are properly connected, check the server and network communication status and consult with the network administrator.
Insert Card in Key/Card Counter	No card in the Key Card Counter (option).	Insert Card in the Key Card Counter.
!! Job Separator is OFF !! Turn On Power Switch of it	The Job Separator (option) is turned OFF.	Turn on the Job Separator.

Message	Possible Cause	Action
Linked Printer in Error	A Service Call Error has occurred on the Linked Printer.	Check the Linked Printer and resolve the error.
No IP Address Assigned to This Printer Contact Your Network Administrator	IP address for the machine is not properly set.	Contact your system administrator and set the machine IP address correctly. p.162
!! No Linked Printer Detected !! Check Cable Connection and Power Supply for Linked Printer	Linked Printer may not be turned ON; cable may not be properly connected; connection may be interrupted.	Check that the Linked Printer has been switched on. Check to make sure all cables are properly connected. If properly connected, check for damaged cable.
No Paper Tape in Job Separator Replace Tape Roll	No tape in the Job Separator (option).	Load new tape into the Job Separator.
No Toner in Linked Printer	No toner in the Linked Printer.	Replace toner in the Linked Printer.
Paper Tape Jam in Job Separator Remove Paper Tape	Tape jam occurred in the Job Separator (option).	Check the Job Separator and remove jammed tape.



C00-000:Consumable Errors (in alphabetical order)

Message	Possible Cause	Action
Load Paper in Standard Feed Tray	No printing paper in the Paper Feed Tray.	Load paper into the Paper Feed Tray. ☞ p.33
Master Disposal Box 1 is Full Empty Master Disposal Box	The Master Disposal Box is full.	Empty the Master Disposal Box. ☞ p.248 Install a new Master Roll.
Master Disposal Box 2 is Full Empty Master Disposal Box		
No Ink in Print Cylinder 1 Replace Ink Cartridge	The ink is depleted.	Replace and install a new Ink Cartridge. Use the Ink Cartridge specifically designed and approved for use with this machine ☞ p.246 Important!: • If the error persists after replacing the Ink Cartridge, check for proper installation of the Ink Cartridge.
No Ink in Print Cylinder 2 Replace Ink Cartridge		
No Master Replace Master Roll	The Master Roll is depleted.	Install a new Master Roll. Use Master Roll specifically designed and approved for use with this machine ☞ p.243

D00-000:Installation Error (in alphabetical order)

Message	Possible Cause	Action
Close Front Cover	The Front Cover is open or improperly closed.	Check for the magnet underneath the Front Cover and firmly close.
Close Master Making Unit Cover	The Master Making Unit Cover is open or is improperly installed.	Pull out the Master Making Unit, check and firmly close its cover.
Close the ADF Cover	Optional Auto Document Feeder DX-1 cover is open or incorrectly set.	Check the ADF Cover and close it firmly.
Install Ink Cartridge in Print Cylinder 1	The Ink Cartridge is improperly installed or is missing.	Properly install the Ink Cartridge. ☞ p.246
Install Ink Cartridge in Print Cylinder 2		
Master Making Unit has been Unlocked	The Master Making Unit is ready to be pulled out.	Pull out the Master Making Unit.
Print Cylinder 1 has been Unlocked	The Print Cylinder (Drum) is ready to be pulled out.	Pull out the Print Cylinder (Drum).
Print Cylinder 2 has been Unlocked		

Message	Possible Cause	Action
Print Cylinder 1 is not Set in Place Press Cylinder Release Button and Pull Out Print Cylinder Once after Button Lights	The Print Cylinder (Drum) is locked but not pushed in properly.	Press the Print Cylinder (Drum) Release Button . Remove the Print Cylinder (Drum) after the button is lit and reinstall.
Print Cylinder 2 is not Set in Place Press Cylinder Release Button and Pull Out Print Cylinder Once after Button Lights		
Rear Cover of Main Body is Off Call Service	The machine rear cover is removed.	Contact your dealer (or authorized service representative).
Set Master Disposal Box 1 in Place	The Master Disposal Box is improperly set or is missing.	Properly set the Master Disposal Box. ☞ p.248
Set Master Disposal Box 2 in Place		
Set Master in Place	No master is installed.	Install a Master Roll. ☞ p.243
Set Master Making Unit in Place	The Master Making Unit is missing or is improperly installed.	Properly install the Master Making Unit. ☞ p.243
Set Print Cylinder 1 in Place	The Print Cylinder (Drum) is improperly set or is missing.	Properly install the Print Cylinder (Drum). ☞ p.250
Set Print Cylinder 2 in Place		
Wrong-type Ink Cartridge Installed in Cylinder 1 or Cannot Read Ink Info Replace Ink Cartridge or Contact Dealer/Riso Office	Inappropriate Ink Cartridge is installed.	Properly install a correct Ink Cartridge. ☞ p.246 Important!: • Use the Ink Cartridge specifically designed and approved for use with this machine. Failure to do so may cause problems or damage to the machine.
	The label on the Ink Cartridge outlet surface has come off or surface is with dirt.	The label on the Ink Cartridge outlet surface contains information needed for printing. If the machine cannot read the information, it does not operate. Set an Ink Cartridge that is specific to the machine and that is with label attachment and free from dirt.

Message	Possible Cause	Action
Wrong-type Ink Cartridge Installed in Cylinder 2 or Cannot Read Ink Info Replace Ink Cartridge or Contact Dealer/Riso Office	Inappropriate Ink Cartridge is installed.	Properly install a correct Ink Cartridge. ☞ p.246 Important!: <ul style="list-style-type: none"> Use the Ink Cartridge specifically designed and approved for use with this machine. Failure to do so may cause problems or damage to the machine.
	The label on the Ink Cartridge outlet surface has come off or surface is with dirt.	The label on the Ink Cartridge outlet surface contains information needed for printing. If the machine cannot read the information, it does not operate. Set an Ink Cartridge that is specific to the machine and that is with label attachment and free from dirt.
Wrong-type Master Installed or Cannot Read Master Info Replace Master Roll or Contact dealer/Riso office	Incorrect master is installed.	Set a correct Master Roll. ☞ p.243 Important!: <ul style="list-style-type: none"> Use a Master Roll specifically designed and approved for use with this machine. Failure to do so may cause problems or damage to the machine.
	The  section on the master core is missing, or it has worn off, or it has been tilted.	The  section on the master core contains information needed for making masters. If the machine cannot read the information, it does not operate. Set a dedicated Master Roll that has the  mark and is free from wear and tilt.
Wrong-Type Print Cylinder Installed in Cylinder Position 1 Replace with Correct Type	Incorrect Print Cylinder (Drum) is installed.	Install a correct Print Cylinder (Drum). ☞ p.250 Important!: <ul style="list-style-type: none"> Use a Print Cylinder (Drum) specifically designed and approved for use with this machine. Failure to do so may cause problems or damage to the machine.
Wrong-Type Print Cylinder Installed in Cylinder Position 2 Replace with Correct Type		

J00-000:Paper Jam Error

Displays when the original document or printing paper is jammed inside the machine or the ADF unit (option).

The location of the paper jam is indicated by the flashing icon (①-⑤) in the illustration. Refer to the table below (①-⑤) and resolve the issue as indicated.

Note:

- Use appropriate printing paper to prevent paper jams. Also select appropriate original document suitable for the ADF unit.
 - ☞ p.14
 - ☞ p.16

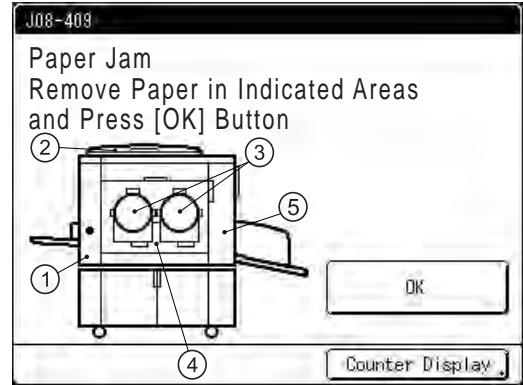

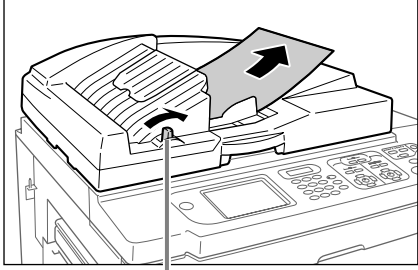
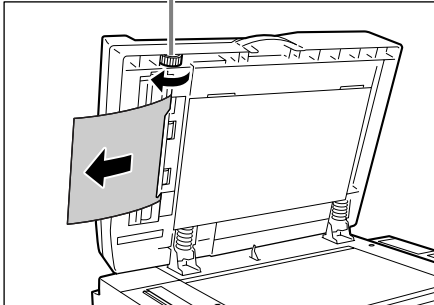
Area Indicated/ Blinking	Possible Cause	Action
①	Paper is jammed in the Paper Feed area.	<ol style="list-style-type: none"> 1) Check the paper feed side and remove the jammed paper. 2) Touch [OK]. <p>Note:</p> <ul style="list-style-type: none"> • When using special paper, adjust the Paper Feed Pressure Adjustment Lever according to the paper characteristics. ☞ p.33
②	The original is jammed in the ADF unit (option).	<p>◆ For Auto Document Feeder AF-VI:II</p> <p>Removing in the document insertion direction Pull the ADF Original Release Lever to the right, and pull out the original.</p>  <p style="text-align: center;">ADF Original Release Lever</p> <p>Removing in the document ejection direction Raise Stage Cover, turn the ADF Original Release Dial and remove the original.</p> <p style="text-align: center;">Original Release Dial</p> 

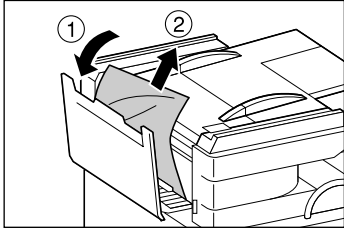
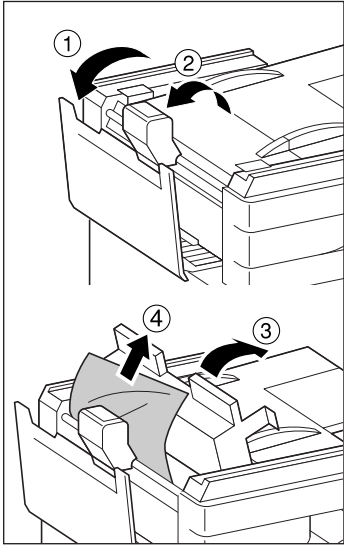
Area Indicated/ Blinking	Possible Cause	Action
<p>②</p>	<p>The original is jammed in the ADF unit (option).</p>	<p>◆ For Auto Document Feeder DX-1</p> <p>Important!</p> <ul style="list-style-type: none"> Take care not to touch the roller inside the unit. It may cause smudges on the original or a paper jam. <p>Removing originals jammed in the document feeder Open the ADF Cover (①), and pull out the original (②).</p>  <p>Removing originals jammed in the document carrier Open the ADF Cover (①), and raise the feed roller as shown (②). Open the inside cover (③), and pull out the original (④).</p> 

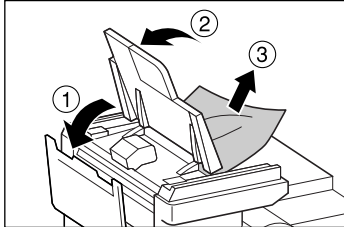
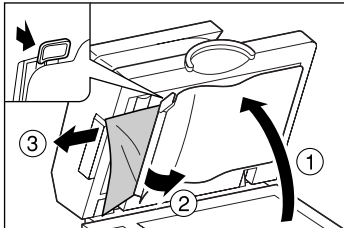
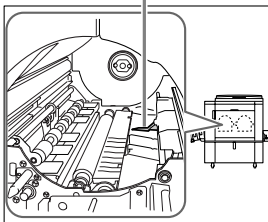
Area Indicated/ Blinking	Possible Cause	Action
<p>②</p>	<p>The original is jammed in the ADF unit (option).</p>	<p>◆ For Auto Document Feeder DX-1</p> <p>Removing originals jammed in the duplex document carrier Open the ADF Cover (①), and raise the document tray as shown (②). Pull out the original (③).</p>  <p>Removing originals jammed in the original receiving unit Lift the Stage Cover Pad up (①), pull the release lever toward you (②), and pull out the original (③).</p> 
<p>③ ④</p>	<p>Paper is jammed in the Print Cylinder (Drum) area.</p>	<ol style="list-style-type: none"> 1) Pull out the Print Cylinder (Drum). <small>☞ p.250</small> 2) Remove the jammed paper. 3) Return the Print Cylinder (Drum) in place. 4) Touch [OK]. <p>⚠ Caution:</p> <ul style="list-style-type: none"> • Be careful not to touch the separation hook when putting your hands inside to remove paper. The edge of the separation hook is sharp and can cause injury. <p style="text-align: center;">Separation Hook</p> 

Area Indicated/ Blinking	Possible Cause	Action
⑤	Paper did not eject correctly.	<ol style="list-style-type: none"> 1) Check for any jammed paper on the paper exit area. 2) Touch [OK]. <p>Note:</p> <ul style="list-style-type: none"> • When using special paper, adjust the Paper Arranger on the Receiving Tray Paper Guides according to the paper characteristics. <p>☞ p.35</p>

Pop-Up Message Layout

Pop-Up Messages communicates various operational statuses.



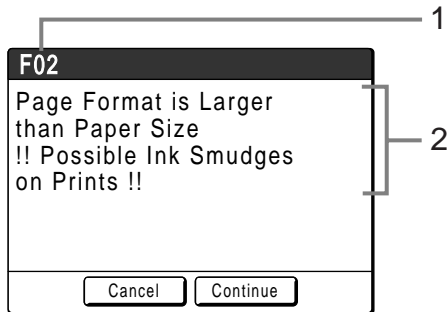

You can continue operation over some of them, but depending upon the context, others will require your action before operations can be resumed.











- 1) **Error Number**
A reference letter (E/F) and an ID number.
- 2) **Pop-Up Messages**
Content of the message.





Error Number	Error Types	Description	Reference page
E00-000	Maintenance Call	Pops up when battery replacement or a routine inspection by a service personnel is required.	p.273
F00-000	Warning Messages	Pops up when printing job cannot proceed due to a conflict between a Control Panel setting and the status of the machine or the Linked Printer.	p.274











E00-000:Maintenance Call (in alphabetical order)





Message	Symptom	Action
!!Low Battery!! Call Service	Low battery.	Touch [Close] . (Alternatively, press the  key or the  key to clear.) Contact your dealer (or authorized service representative) and have the battery replaced.
!!Maintenance!! Call Service	Notifies user of need for a periodic maintenance.	Touch [Close] . (Alternatively, press the  key or the  key to clear.) Consult your dealer (or authorized service representative).



F00-000:Warning Messages (in alphabetical order)

Message	Symptom	Action
Acquiring Linked Printer Configuration Data Please Wait a Moment	The machine system is retrieving Linked Printer information. Link Mode printing is disabled while the retrieval is underway.	Touch [Close] to clear the Pop-Up Message and return to the previous screen. <ul style="list-style-type: none"> • When printing from the machine; Press the  key or the  key. • When printing from a Linked Printer; Wait until the information has been retrieved. (This may take several minutes.)
!!Auto-Link Operation is Not Available!! Specified Linked Printer may be in Error or Turned OFF	Linked Printer is sending an error signal. Link Mode has been activated due to low print volume since "Link-Free Volume" is currently set to ON.	<ul style="list-style-type: none"> • When returning to the Master Screen; Touch [Cancel]. (Alternatively, press the  key or the  key to clear.) • When changing to another available Linked Printer; Touch [Link Switch] and select another Linked Printer on the Link Sw. screen. ([Link Switch] will not display if no other Linked Printer is available.) ☞ p.230
!! Book Shadow Editor is Not Available with ADF !! Place Original on Stage Glass	ADF unit is disabled while Book Shadow function is active.	Touch [Close] . (Alternatively, press the  key or the  key to clear.) Place the original on the Stage Glass. ☞ p.84
Check Stock of Required Ink and Please Order If Needed	The remaining quantity of Ink Cartridge or Master Roll has become less than specified on "Stock Management". ☞ p.177	Touch [Close] . (Alternatively, press the  key or the  key to clear.) Order Ink Cartridges or Master Rolls if necessary.
Check Stock of Required Master and Please Order If Needed		
!! Complicated Area Form !! Re-circle Editing Areas and Redo Color Separation	The shape of the selected area is too complicated to be recognized.	Do not overlap the pen areas. If the edges touch, the specified area may not be recognized. Make the shape of the area as simple as possible. ☞ p.50
Dual-Color Printing is Not Available for This Paper Size Load Paper Larger than B5(Portrait)	This machine cannot perform 2-Color printing on paper smaller than B5 size.	Touch [Close] and proceed to load paper with vertical dimension larger than that of B5 (10 ¹ / ₈ " (257 mm)).

Message	Symptom	Action
Either of Masters is Made in Ink Saving Process Operate Dual-Color Printing?	One of the masters on either Cylinder (Drum) 1 or Cylinder (Drum) 2 was created in "Ink Saving" mode, while the other master is of regular printing quality.	Proceeding to print with existing set of masters by simply touching [Continue] button will result in poor color balance, i.e., one of the colors may be too dark or too light. To correct this problem, touch [Cancel] and create another set of masters in the same mode.
Enter Print Quantity Over [nn], Programed Minimum Value	You are trying to print fewer copies than previously specified on "Minimum Print Quantity".	Touch [Close] , and specify the number of copies higher than the number displayed on the message. <i>or</i> You can change "Minimum Print Q'ty" on the Admin. screen. ☞ p.177
!! Exceeding Number of Editing Areas Selected !! Deselect Some Areas and Redo Color Separation	Too many areas are selected.	Up to 20 pen areas may be selected. Reduce number of selected areas.
!! Multi-Up is Not Available with This Paper Size !! Replace with Proper Paper of Standard Size	Multi-up functions cannot be used when custom-sized paper is in the Paper Feed Tray.	Touch [Close] . (Alternatively, press the  key or the  key to clear.) Load standard size paper in the Paper Feed Tray.
No Master on Print Cylinder 1 Make a New Master	You are attempting to print, but there is no master on the Print Cylinder (Drum).	Touch [Close] . Set the original and create a master. Important! <ul style="list-style-type: none"> Do not leave the Print Cylinder (Drum) without a master. This dries out the cylinder (drum) and causes damage. You must either create a master or perform a "Confidential" operation to wrap a master around the Print Cylinder (Drum).
No Master on Print Cylinder 2 Make a New Master		
!! Number of Copies is set to "0"!! Printing Operation will Start on this Printer	Number of print copies is set to "0", yet "Link-Free Volume" is set to ON when Linked Printer is connected.	<ul style="list-style-type: none"> When printing from the machine; Touch [Continue]. (Alternatively, press the  key to print.) When stopping the print job; Touch [Cancel]. (Alternatively, press the  key or the  key to clear.) Then, enter print quantity. ☞ p.178

Message	Symptom	Action
Original Undetected Reset Original	The machine failed to detect the original document. The original document may not be placed.	Re-position the original to clear the Pop-Up Message. <ul style="list-style-type: none"> • When resuming the print job; Touch [Continue]. (Alternatively, press the  key to print.) • When stopping the print job; Touch [Cancel]. (Alternatively, press the  key or the  key to clear.)
!! Outlines of Editing Areas are Too Long !! Divide Large Areas into Several Smaller Areas and Redo Color Separation	Selected area is larger than the print paper size.	Reduce the size, or select smaller areas.
Page Format is Larger than Paper Size !! Possible Ink Smudges on Prints !!	The printing paper is smaller than the Master.	<ul style="list-style-type: none"> • To override the message and to print with possible ink smears on the roller; Touch [Continue]. (You can also print by pressing the  key or the  key.) • When stopping the print job; Touch [Cancel]. (You can also stop by pressing the  key or the  key.) Load the correct size printer paper.
Page Format is Larger than Paper Size !! Possible Ink Smudges on Prints !! (Continue->PROOF Key)	The printing paper is smaller than the Master.	<ul style="list-style-type: none"> • To override the message and to print with possible ink smears on the roller; Press the  key. • When stopping the print job; Touch [Cancel]. (You can also stop by pressing the  key or the  key.) Load the correct size printer paper.
Printer Temperature is Low "150ppm" is Not Available	Current temperature is too low for "150ppm" printing.	You may operate the machine with regular speed by touching [Continue] , until temperature within the machine reaches 59°F (15°C). To return to Print Basic Screen, touch [Cancel] .
Printing is Not Available for This Paper Size with Print Cylinder 2 Set Print Cylinder to be Used in Cylinder Position 1 and Re-select Printing Mode	Cylinder (Drum) 2 may be used for single color printing, but only on certain paper size. Paper size currently loaded does not support single color printing with Cylinder (Drum) 2).	Touch [Close] . Remove Cylinder (Drum) 2 from its current position, and replace it in place of Cylinder (Drum) 1. See  p.14 for paper size limitation when printing single color using Cylinder (Drum) 2.

Message	Symptom	Action
Printing is Not Available for This Setting with Print Cylinder 2 Set Print Cylinder to be Used in Cylinder Position 1 and Re-select Printing Mode	Cylinder (Drum) 2 may be used for single color printing, but certain limitations apply. Current settings do not support single color printing with Cylinder (Drum) 2.	Touch [Close] . Remove Cylinder (Drum) 2 from its current position, and replace it in place of Cylinder (Drum) 1.
Processing Other Operation Retry after a while	Color separation cannot be performed while system is busy processing another operation.	Please wait until the current operation is completed.
Processing Print Data from PC Scanning Mode is Not Available while Processing Current Data	The machine is receiving the document data from the computer. While the data is being transmitted, Link Mode printing and Scan mode are disabled.	Touch [Close] . Initiate the Print job after the transmission is complete, or print from the machine.
Processing Print Data from PC This Function is Not Available while Processing Current Data		
! Scanning is Not Possible ! External CI is not Connected or Processing Connection Check Cable Connection	(Symptom) The scanning function is unavailable due to a lost connection with an external controller or because connection processing has not finished. (Action) Check the connection with the external controller.	Touch [Close] . (Alternatively, press the  key or the  key to clear.)
Starting Up RISORINC-NET Please Wait a Moment	RISORINC-NET is starting up.	Touch [Close] . (Alternatively, press the  key or the  key to clear.) Please wait a moment. Alternatively, print from the machine.
!! Unmatched Color -- Data Color and Cylinder Color 1 !! Change Print Cylinder	The color of the cylinder (drum) is different from the color specified on printer driver.	<ul style="list-style-type: none"> To ignore printer driver setting and to print with the color currently installed on the cylinder (drum), touch [Continue]. To change color, touch [Cancel] and replace cylinder (drum).
!! Unmatched Color -- Data Color and Cylinder Color 2 !! Change Print Cylinder		
!! Unmatched Color -- Data Color and Cylinder Colors !! Change Print Cylinders		

Message	Symptom	Action
<p>!! Unmatched Size-- Current Page and Printing Paper !! Check Paper Size</p>	<p>The original data sent from the computer does not match the print paper size.</p>	<ul style="list-style-type: none"> • When resuming the print job; Touch [Continue]. (Alternatively, press the  key to print.) • When stopping the print job; Touch [Cancel]. (Alternatively, press the  key or the  key to clear.) <p>Check the print paper size and change paper or size as needed.</p>

Consumable Information Screen

In order to assure optimum printing, the machine acquires information from the consumables. If acquired matching information is not proper, the Consumable Information screen is shown. Enter appropriate values.

The **i** icon on the Info Button will be grayed out when this occurs.

☞ p.242

Note:

- Entering an inappropriate value does not affect usual operations but may result in bad print quality.
- When you perform the following operations, the values set on the "Consumables Information Input Wizard" screen disappears and thus you need to enter the values again.
 - After the power switch is set to **○** (OFF), the switch is set to **■** (ON) again
 - After the machine is placed into the Sleep status, the **Ⓢ** key is pressed
- If you are not sure the best setting for the consumables used in the machine, we may suggest that you use "1" (default setting) except for "H1" setting and adjust from there if necessary based on the result of the printed copies. Riso takes no responsibility, and cannot advise as to the best setting, for particular consumables not manufactured and sold by Riso.

Ink Information Input Screen

This screen pops up when data could not be obtained from the Ink Cartridge.

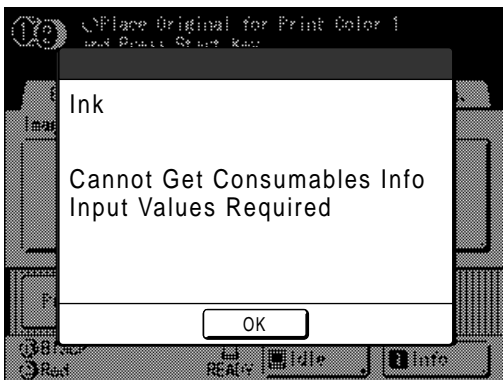

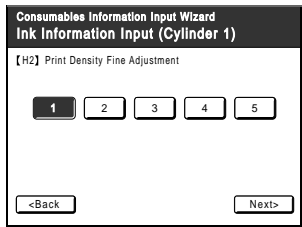
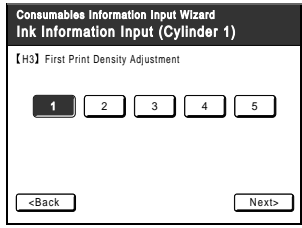

Touch **[OK]** and enter values as shown below.

Screen Display	Description	Values
	<p>[H1] Ink Color Setting (for Print Cylinder (Drum) 1) [H7] Ink Color Setting (for Print Cylinder (Drum) 2) Select the same color as the Print Cylinder (Drum) currently in use.</p>	<p>1: Black 2: Color</p>

Screen Display	Description	Values
	<p>[H2] Print Density Fine Adjustment (for Print Cylinder (Drum) 1) [H8] Print Density Fine Adjustment (for Print Cylinder (Drum) 2) Select a Print Density level to match the ink to fine-tune print result.</p>	1 (Light) - 5 (Dark)
	<p>[H3] First Print Density Adjustment (for Print Cylinder (Drum) 1) [H9] First Print Density Adjustment (for Print Cylinder (Drum) 2) Select a Print Density level of the first print to match the ink.</p>	1 (Light) - 5 (Dark)

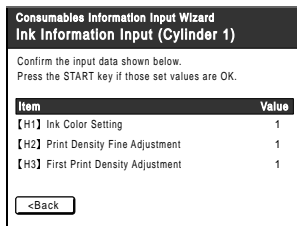
A confirmation screen displays when done.



Press the  key to approve selection.
 Returns to the Basic Screen.

Note:

- Master Information Input screen may also display. If so, enter Master Information as well.
 p.280

Master Information Input Screen

This screen pops up when data could not be obtained from the Master Roll.
 Touch [OK] and enter values as shown below.

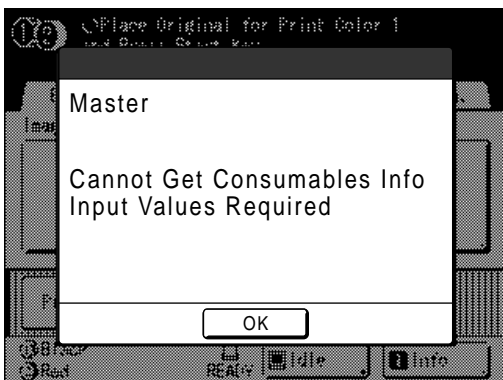

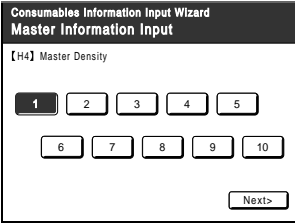
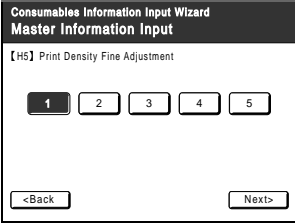
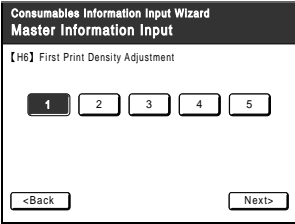
Screen Display	Description	Values
	<p>[H4] Master Density Select the standard density to be applied during creation of the master.</p>	<p>1 (Light) - 10 (Dark)</p>
	<p>[H5] Print Density Fine Adjustment Select a Print Density level to match the master to fine-tune print result.</p>	<p>1 (Light) - 5 (Dark)</p>
	<p>[H6] First Print Density Adjustment Select a Print Density level of the first print to match the master.</p>	<p>1 (Light) - 5 (Dark)</p>



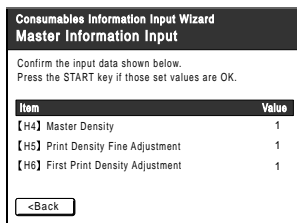



A confirmation screen displays when done.





Press the  key to approve selection.
Returns to the Basic Screen.

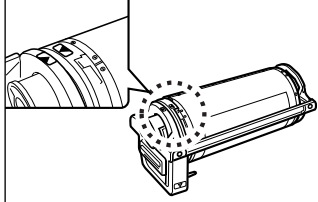

Troubleshooting

If you run into a problem, consult the following chart first to find answers before calling for a repair.

Problem	Possible Cause	Action
The machine does not start up when the power switch is pressed.	You may have pressed the power switch while the machine was in the Sleep Mode.	Try pressing the power switch again. Before pressing the power switch, you may want to find out whether the machine is indeed in the Sleep Mode, by checking the  indicator on the Control Panel. If the  key is lit, the machine is in sleep mode. Press the  key to end sleep mode and to activate the machine.
	Power has been disconnected.	<ul style="list-style-type: none"> • Check the electric cord for proper connection to both the machine and the power outlet. • Check the power breaker.
The front cover is closed, but the error message still does not clear.	The Front Cover has not been firmly closed.	Completely close the Front Cover. The magnetic latch should properly engage.
The Paper Feed Tray cannot be closed.	The Feed Paper Tray Guides have not been widened up to the limit.	Turn the power on and lower the Paper Feed Tray to the bottom. Set the Feed Tray Paper Guide Lock Lever to  , widen the Feed Tray Paper Guides up to the limit, and close the Paper Feed Tray.
	The power was turned off before the Paper Feed Tray was lowered to the bottom.	
The Print Cylinder (Drum) cannot be placed into position.	The Print Cylinder (Drum) was stopped at an inappropriate position after rotation.	After manually rotating the cylinder (drum), make sure that the  mark and the  mark meet as shown. 
	The Print Cylinder (Drum) has not been correctly set to the guide.	Set the cylinder (drum) to the guide correctly. ☞ p.252

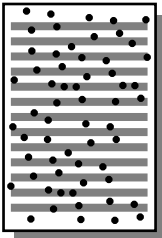
Problem	Possible Cause	Action
<p>An error indication does not disappear even though consumables (ink, master roll) are set.</p>	<p>The consumables (ink, master roll) have not been correctly set.</p>	<p>After inserting the Ink Cartridge, turn it clockwise (🔒) to lock. Or set the Ink Cartridge again. ☞ p.246</p> <p>Set a master roll so that the 📄 mark comes to the left, and set the Master Making Unit. ☞ p.243</p>
	<p>The Ink Cartridge does not contain ink information.</p>	<p>Do not remove the label attached on the Ink Cartridge outlet section. If you did so, set a new Ink Cartridge. ☞ p.243</p>
	<p>The master roll does not contain master information.</p>	<p>Do not remove the 📄 section from the master core. If you did so, set a new master roll. ☞ p.243</p>
<p>The Master Disposal Box cannot be removed.</p>	<p>The “Protect” setting is ON.</p>	<p>If the “Protect” setting is ON, the Master Disposal Box cannot usually be removed. ☞ p.190</p>
	<p>The Master Disposal Box lever is locked.</p>	<p>Slide the Master Disposal Box lever to the right to unlock. If the Master Disposal Box is padlocked, contact the administrator to undo the padlock. ☞ p.248</p>
<p>There is no image on copies.</p>	<p>The original is placed face up.</p>	<p>Place the original face down. (This is also true for the ADF unit)</p>
<p>Some areas are missing in the printed copy.</p> 	<p>The Stage Glass (and/or the ADF Scanner Glass) is not clean.</p>	<p>Clean the Stage Glass (and/or the ADF Scanner Glass). ☞ p.256</p>
	<p>A foreign object may exist on the master.</p>	<p>Pull out the Print Cylinder (Drum) and check if any object exists on the master. If a foreign object exists between the master and the cylinder (drum), remove the master. Then set the cylinder (drum) and perform the master-making operation again.</p>
	<ul style="list-style-type: none"> • The paper size placed on the Paper Feed Tray was not the same as the size of the original at the time of the master-making process. • The Feed Tray Paper Guides were not fit to the width of paper at the time of the master-making process. 	<p>A master is made according to the size of paper placed on the Paper Feed Tray; namely the width of the Feed Tray Paper Guides and the length of paper. If the size of paper placed on the tray is smaller than the size of the original, a master is not made for the entire original. Set the same size of paper on the tray as the original and perform the master-making operation.</p>

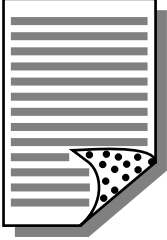
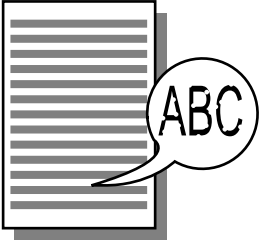
Problem	Possible Cause	Action
<p>Vertical blank lines are found on printed copies.</p> 	<p>The Thermal Print Head of the Master Making Unit or the Scanner Glass of ADF unit has been stained with dirt, white-out, etc.</p>	<p>Gently wipe the Thermal Print Head or Scanner Glass with a soft cloth. ☞ p.256</p>
<p>The unwanted background of an original is picked up on copies.</p> 	<p>If newspaper or colored paper is used as an original, the background is picked up on copies.</p>	<p>Lighten the “Contrast” and create a new master. ☞ p.77</p>
<p>Dirt is found on printed copies.</p>	<p>The Stage Glass (and/or the ADF Scanner Glass) is not clean.</p>	<p>Clean the Stage Glass (and/or the ADF Scanner Glass). ☞ p.256</p>
<p>The edges of printed copies are smudged with ink.</p>	<p>Larger size of paper than the original was placed on the Paper Feed Tray at the time of the master-making process.</p>	<p>Because a master was made according to a larger size than the original, the edges of the original were processed as shadows. Set the same size of paper as the original and perform the master-making operation again. Or attach tape as described below to solve the problem.</p>
	<p>Did you use [Max. Scan] setting when making the master?</p>	
	<p>When printing thick paper such as cards, corners of the paper contacted and damaged the master.</p>	<p>Make another master and print with the new master. Or pull out the Print Cylinder (Drum) and attach cellophane tape to the damaged section on the master. However, if attached with cellophane tape, a master may not be properly sent to the Master Disposal Box.</p>

Problem	Possible Cause	Action
<p>The back of the printed paper is smudged with ink</p> 	<p>The Pressure Roller has been stained with ink.</p>	<p>Remove the Print Cylinder (Drum) and clean the Pressure Roller. ☞ p.256 If the print position is outside the print paper, this may cause the Pressure Roller to be stained with ink. Be careful when changing the size of print paper or shifting the print position.</p>
	<p>The Feed Tray Paper Guides were not fit to the width of paper at the time of the master-making process.</p>	<p>Adjust the Feed Tray Paper Guides to the width of the paper. If the Feed Tray Paper Guides are set wider than the width of the paper, a master will become wider than necessary. ☞ p.33</p>
	<p>Are you using a paper that does not efficiently absorb ink?</p>	<p>The ink did not dry fast enough, marking onto the reverse side of the next paper. Either change the paper or try “Ink Saving” or “Interval” features. ☞ p.86 ☞ p.120</p>
<p>Printed images are faint. Printed texts are blurred.</p> 	<p>If the machine is not used for an extended period of time, ink on the surface of the Print Cylinder (Drum) may dry. This results in faint or blurred printing just after printing is started.</p>	<p>The ink on the Print Cylinder (Drum) will dry when the machine is not in use for an extended period. Printing with dried ink will produce light or faded copies. Press the  key and make several copies before making copies to be actually used. Or use the “Idling Action”. ☞ p.160</p>
	<p>Faint originals result in faint images.</p>	<p>Increase the scanning level and perform the master-making operation again. ☞ p.77 For originals written with a pencil, select the Pencil mode. ☞ p.70</p>
	<p>If the temperature is low (below 59°F (15°C)) in a place where the machine is installed or Ink Cartridges are stored, ink does not flow smoothly.</p>	<p>Use the machine after keeping it at room temperature for a while. ☞ p.10</p>
	<p>The Ink Saving mode has been set.</p>	<p>With the “Ink Saving” mode selected, the ink on printed copies is fainter than usual. ☞ p.86</p>

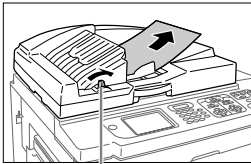
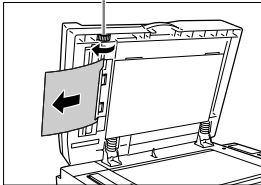

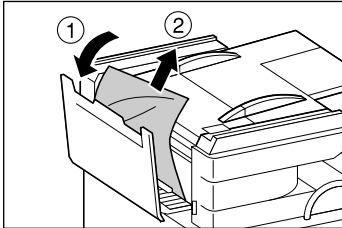
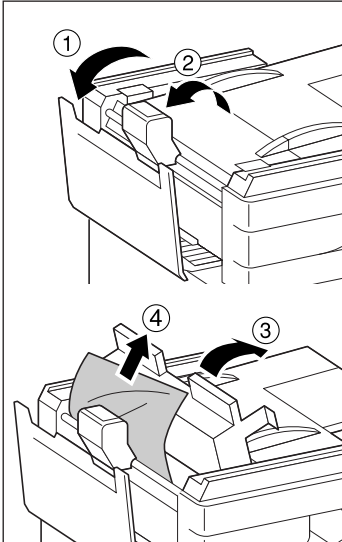
Problem	Possible Cause	Action
<p>Paper sticks to the surface of the Print Cylinder (Drum).</p>	<p>The margin at the top of the original or print is too small.</p>	<p>The margin of the original (top of the print in the paper output direction) must be $\frac{3}{16}$" (5 mm) at least. Lower the vertical print position. If this adjustment is impossible, reproduce an original with enough margin and perform the master-making operation again. ☞ p.78</p>
	<p>The print paper is inappropriate.</p>	<p>Use the recommended paper. ☞ p.14</p>
	<p>The original has a solid black portion at its top.</p>	<p>If an original has a solid black portion at the top, printed copies may not properly output. Replace the original in the reverse direction and restart the master-making process.</p>
<p>Printed and curled copies are output.</p>	<p>The print paper is loaded at a horizontal grain direction.</p>	<p>Load print paper with a vertical grain direction.</p>
<p>Paper gets jammed in the Auto Document Feeder AF-VI:II (option).</p>	<p>There is any paper caught in the Auto Document Feeder AF-VI:II.</p>	<p>Pull the ADF Original Release Lever to the right or turn the Release Original Dial and remove the jammed paper.</p> <div style="text-align: center;">  <p>ADF Original Release Lever</p>  <p>Original Release Dial</p> </div>

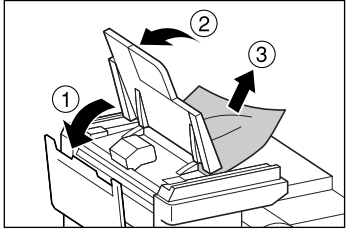
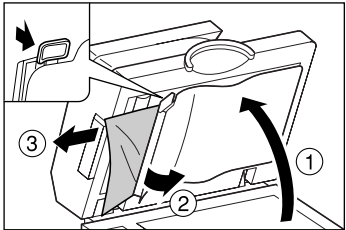
Problem	Possible Cause	Action
<p>Paper gets jammed in the Auto Document Feeder DX-1 (option).</p>	<p>Paper is caught in the Auto Document Feeder DX-1.</p>	<p>Follow the steps below to remove the jammed paper.</p> <p>Important!:</p> <ul style="list-style-type: none"> Take care not to touch the roller inside the unit. It may cause smudges on the original or a paper jam. <p>Removing originals jammed in the document carrier Open the auto document feeder cover (①), and raise the feed roller as shown in (②).</p>  <p>Removing originals jammed in the document carrier Open the auto document feeder cover (①), and raise the feed roller as shown in (②). Open the inside cover (③), and pull out the original (④).</p> 

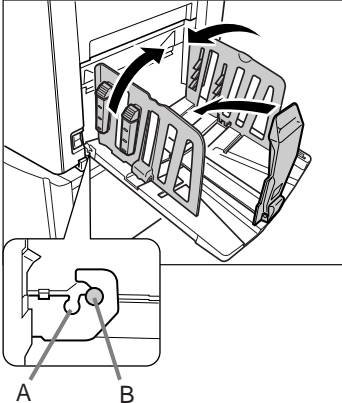
Problem	Possible Cause	Action
<p>Paper gets jammed in the Auto Document Feeder DX-1 (option).</p>	<p>There is any paper caught in the Auto Document Feeder DX-1.</p>	<p>Removing originals jammed in the original reversal unit Open the auto document feeder cover (①), and raise the document tray as shown in (②). Pull out the original (③).</p>  <p>Removing originals jammed in the original receiving unit Lift the Stage Cover Pad up (①), and pull the release lever toward you (②), and pull out the original (③).</p> 
<p>Printed copies are not neatly aligned in the Paper Receiving Tray.</p>	<p>The positions of the Receiving Tray Paper Guides and the Paper Stopper are inappropriate.</p>	<p>Adjust the Receiving Tray Paper Guides and the Paper Stopper to the size of paper. For thick paper, slightly widen them as necessary. If you have adjusted the horizontal position on the Paper Feed Tray, shift the Receiving Tray Paper Guides in the same direction. ☞ p.35</p>
	<p>The Paper Arrangers are not properly set.</p>	<p>Set the Paper Arrangers properly. ☞ p.35</p>

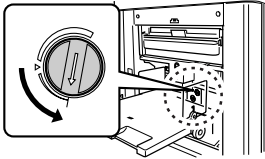
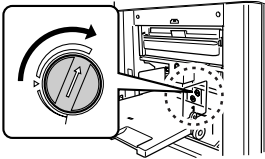
Problem	Possible Cause	Action
<p>Paper goes over the receiving tray stopper.</p>	<p>---</p>	<p>Follow the steps to level the receiving tray as follows:</p> <ol style="list-style-type: none"> 1) Fold the Receiving Tray Paper Guides/Stopper. 2) Lift up the sides of the receiving tray with both hands, and move the receiving tray shaft to position B. Position A is recommended in most cases.  <p>A: Ordinary position B: Move to this position when paper goes over the tray.</p>

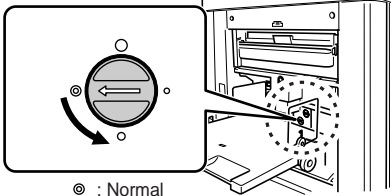
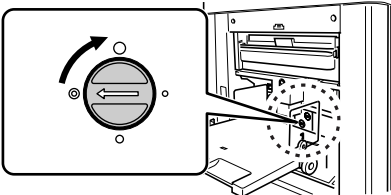
Problem	Possible Cause	Action
<ul style="list-style-type: none"> Paper is not smoothly fed from the Paper Feed Tray. (skipped paper, or multiple-sheet feeding) There is a lot of paper powder Multiple sheets of paper were fed Construction paper or postcard was skipped The back side of the postcard is turned up 	<p>The print paper is inappropriate.</p>	<p>Use paper that falls within the recommended range. ☞ p.14</p>
	<p>The position of the Paper Feed Pressure Adjustment Lever was inappropriate.</p>	<p>When using thick or slippery paper, set the Paper Feed Pressure Adjustment Lever to “Thick Paper”. ☞ p.33</p>
	<p>The angle of the Stripper Plate is inappropriate.</p>	<p>Turn the Stripper Plate Angle Adjustment dial as follows;</p> <ul style="list-style-type: none"> When the feeding skips Turn the dial to the left.  <ul style="list-style-type: none"> When multiple sheets are fed Turn the dial to the right.  <p>Important!:</p> <ul style="list-style-type: none"> Before making the adjustment, be sure to remove all paper from the Paper Feed Tray and confirm that the tray has lowered to the bottom.

Problem	Possible Cause	Action
<ul style="list-style-type: none"> Paper is not smoothly fed from the Paper Feed Tray. (skipped paper, or multiple-sheet feeding) There is a lot of paper powder Multiple sheets of paper were fed Construction paper or postcard was skipped The back side of the postcard is turned up 	<p>Paper handling pressure is not correctly adjusted.</p>	<ul style="list-style-type: none"> For paper that easily creates paper powder, skips, or for the back side of postcards that is turn up: Turn the dial to the left.  <p> ⊙ : Normal ○ : Strong ◦ : Medium ◌ : Weak </p> <ul style="list-style-type: none"> If paper is being multi-fed: Turn the dial to the right.  <p>Important!:</p> <ul style="list-style-type: none"> Before making the adjustment, be sure to remove all paper from the Paper Feed Tray and confirm that the tray has lowered to the bottom.
	<p>The Paper Feed Adjustment on the Functions screen is not properly set.</p>	<p>Adjust the “Paper Feed Adj.”. Contact your dealer (or authorized service representative) for details on making the adjustment.</p>
<p>An error message displays even though there is no paper jam.</p>	<p>Is the lifted paper getting ejected at the second rotation of the Print Cylinder (Drum)?</p>	<p>Check the printed copy, and if the top margin is less than 3/16" (5mm), slightly lower Print Position.</p>
	<p>Is sunlight directly hitting the machine?</p>	<p>The sensor is affected by direct sunlight. Install shades or curtains, or move the machine out of direct sunlight.</p>
<p>When printing a multiple page computer file, the machine repeats the master-making process one page at a time.</p>	<p>Is “Print in Units” option selected in the Printer Driver?</p>	<p>Delete the current print job. Deselect “Print in Units”, and resend the data to the machine. See p.63, step 3. p.67</p>
<p>The computer sent the file, but it was not received by the machine.</p>	<p>Is the Admin. screen currently showing on the display?</p>	<p>Touch  and switch to the Basic Screen from the Admin. screen.</p>



Appendix

Optional Accessories

A variety of optional accessories are available to enhance the capabilities of the machine. For details about the optional accessories, see your dealer (or authorized service representative).

◆ Auto Document Feeder AF-VI:II

Feed up to 50 sheets of originals automatically.

◆ Auto Document Feeder DX-1

Feed up to 50 sheets of originals automatically. Both sides of original can be scanned automatically.

◆ Color Cylinder (Drum)

Simply change the Cylinder (Drum) to print in multiple colors. (Case included)

◆ Key Card Counter

With a single button press, shows the numbers of printed copies and consumed masters within a given period of time. This can help you manage costs.

◆ Job Separator

With the Programed Printing function, allows the machine to print and sort into groups separated by tape.

◆ Stand

◆ RISO PRINTER Network Interface Card RISORINC-NET-D:G/GII

Use to directly connect the machine to the network.

This comes with the RISO-MONITOR software that allows you to check the status of the machine from computers.

◆ Special Paper Feed Kit

This unit allows you to feed thicker paper such as cards and envelopes.

◆ Ink/Master Holder

A rack kit for storing supply such as ink and masters.

◆ Document Storage Card DM-128CF

◆ Wide Stacking Tray

Paper Receiving Tray for sizes A6 - A3/Ledger 13.4" × 18.5" (340 mm × 470 mm).

◆ RISO Color Separation Software CS-2000

Easy to use application software for printing multi-colored, computer-generated images on your RISO printer.

◆ RISO Controller PS7R

A custom controller enabling the machine to be used as a network-connected PostScript 3 printer.

Specifications

RISO MZ990

Master-making/printing methods	High-speed digital master-making/full automatic stencil printing
Original Type	Book (22 lb (10 kg) or less), sheet
Original Size (max./min.)	When using the Stage Glass : $1^{15}/_{16}'' \times 3^{9}/_{16}''$ (50 mm × 90 mm) - $11^{11}/_{16}'' \times 17''$ (297 mm × 432 mm) When using Auto Document Feeder AF-VI:II (option) : $3^{15}/_{16}'' \times 5^{13}/_{16}''$ (100 mm × 148 mm) - $11^{11}/_{16}'' \times 17''$ (297 mm × 432 mm) When using Auto Document Feeder DX-1(option) : $4^{1}/_{8}'' \times 5^{1}/_{16}''$ (105 mm × 128 mm) - $11^{11}/_{16}'' \times 17''$ (297 mm × 432 mm)
Original Paper Weight	When using the Stage Glass : 22 lb (10 kg) or less When using the Auto Document Feeder AF-VI:II (option) : 13-lb bond (50 g/m ²) - 34-lb bond (128 g/m ²) When using Auto Document Feeder DX-1 (option) : 11-lb bond (40 g/m ²) - 34-lb bond (128 g/m ²) (When "Scanning Side -ADF" is set to "Back Side → Simplex" or "Duplex → Simplex" : 14-lb bond (52 g/m ²) - 28-lb bond (105 g/m ²))
Print Paper Size (max./min.)	When simultaneously 2-Color printing: $7^{3}/_{16}'' \times 10^{1}/_{8}''$ (182 mm × 257 mm) - $11^{11}/_{16}'' \times 17''$ (297 mm × 432 mm) When 1-Color printing (using Cylinder (Drum) 1): $3^{15}/_{16}'' \times 5^{13}/_{16}''$ (100 mm × 148 mm) - $11^{11}/_{16}'' \times 17''$ (297 mm × 432 mm) When 1-Color printing (using Cylinder (Drum) 2): $7^{3}/_{16}'' \times 10^{1}/_{8}''$ (182 mm × 257 mm) - $11^{11}/_{16}'' \times 17''$ (297 mm × 432 mm)
Paper Supply Capacity	1000 sheets (17-lb bond (64 g/m ²))
Print Paper Weight	13-lb bond (46 g/m ²) - 110-lb index (210 g/m ²)
Image Processing mode	Line, Photo (Standard/Portrait/Group), Duo, Pencil
Master-making Time (for A4/portrait/100% reproduction ratio)	Approx. 57 seconds (for dual-color print) Approx. 24 seconds (for single-color print (Cylinder (Drum) 1)) Approx. 34 seconds (for single-color print (Cylinder (Drum) 2))
Printing Area (max.)	$11^{7}/_{16}'' \times 16^{3}/_{4}''$ (291 mm × 425 mm)
Print Reproduction Ratio	Zoom : 50 - 200% Standard reproduction ratio (enlargement) : 200%, 154%, 129%, 121% Standard reproduction ratio (reduction) : 78%, 65%, 61%, 50% Margin+ : 90 - 99%
Print Speed	Approx. 60 - 150 sheets per minute (Control panel: five steps variable, touch panel: 150 ppm)
Print Position Adjustment	Vertical : $\pm 1^{9}/_{32}''$ (±15 mm) Horizontal : $\pm 3^{3}/_{8}''$ (±10 mm)
Ink Supply	Full automatic (1000 ml per cartridge)
Master Supply/Disposal	Full automatic (approx. 220 sheets per roll)
Master Disposal Capacity	80 sheets
User Interface	LCD Touch Panel with Progress Arrow indicators, front-side operation

Optional Accessories	Auto Document Feeder AF-VI:II, Auto Document Feeder DX-1, Job Separator, Key Card Counter, Color Cylinder (Drum), Network Interface Card RISORINC-NET-D:G/GII, Special Paper Feed Kit, Stand, Document Storage Card DM-128CF, Wide Stacking Tray, RISO Color Separation Software CS-2000, RISO Controller PS7R
Power Source	MZ990 : 100V-120V / 220V-240V AC, 50/60Hz <7.3/3.0A>
Dimensions	When in use : 63 ³ / ₁₆ " (W) × 28 ⁹ / ₁₆ " (D) × 28 ³ / ₄ " (H) (1605 mm (W) × 725 mm (D) × 730 mm (H)) When in storage : 39 ³ / ₄ " (W) × 28 ⁹ / ₁₆ " (D) × 28 ³ / ₄ " (H) (1010 mm (W) × 725 mm (D) × 730 mm (H))
Weight	Approx. 370 ¹ / ₁₆ lb (168 kg)

Note:

- Please note that due to improvements and changes to the machine, some images and explanations in this manual may not correspond to your machine.
- The specifications are subject to change without prior notice.

RISO MZ790

Master-making/printing methods	High-speed digital master-making/full automatic stencil printing
Original Type	Book (22 lb (10 kg) or less), sheet
Original Size (max./min.)	When using the Stage Glass : 1 ¹⁵ / ₁₆ " × 3 ⁹ / ₁₆ " (50 mm × 90 mm) - 11 ¹¹ / ₁₆ " × 17" (297 mm × 432 mm) When using Auto Document Feeder AF-VI:II (option) : 3 ¹⁵ / ₁₆ " × 5 ¹³ / ₁₆ " (100 mm × 148 mm) - 11 ¹¹ / ₁₆ " × 17" (297 mm × 432 mm) When using Auto Document Feeder DX-1(option) : 4 ¹ / ₈ " × 5 ¹ / ₁₆ " (105 mm × 128 mm) - 11 ¹¹ / ₁₆ " × 17" (297 mm × 432 mm)
Original Paper Weight	When using the Stage Glass : 22 lb (10 kg) or less When using the Auto Document Feeder AF-VI:II (option) : 13-lb bond (50 g/m ²) - 34-lb bond (128 g/m ²) When using Auto Document Feeder DX-1 (option) : 11-lb bond (40 g/m ²) - 34-lb bond (128 g/m ²) (When "Scanning Side -ADF" is set to "Back Side → Simplex" or "Duplex → Simplex" : 14-lb bond (52 g/m ²) - 28-lb bond (105 g/m ²))
Print Paper Size (max./min.)	When simultaneously 2-Color printing: 7 ³ / ₁₆ " × 10 ¹ / ₈ " (182 mm × 257 mm) - 11 ¹¹ / ₁₆ " × 17" (297 mm × 432 mm) When 1-Color printing (using Cylinder (Drum) 1): 3 ¹⁵ / ₁₆ " × 5 ¹³ / ₁₆ " (100 mm × 148 mm) - 11 ¹¹ / ₁₆ " × 17" (297 mm × 432 mm) When 1-Color printing (using Cylinder (Drum) 2): 7 ³ / ₁₆ " × 10 ¹ / ₈ " (182 mm × 257 mm) - 11 ¹¹ / ₁₆ " × 17" (297 mm × 432 mm)
Paper Supply Capacity	1000 sheets (17-lb bond (64 g/m ²))
Print Paper Weight	13-lb bond (46 g/m ²) - 110-lb index (210 g/m ²)
Image Processing mode	Line, Photo (Standard/Portrait/Group), Duo, Pencil
Master-making Time (for A4/portrait/100% reproduction ratio)	Approx. 57 seconds (for dual-color print) Approx. 24 seconds (for single-color print (Cylinder (Drum) 1)) Approx. 34 seconds (for single-color print (Cylinder (Drum) 2))
Printing Area (max.)	11 ⁷ / ₁₆ " × 16 ³ / ₄ " (291 mm × 425 mm)
Print Reproduction Ratio	Zoom : 50 - 200% Standard reproduction ratio (enlargement) : 200%, 154%, 129%, 121% Standard reproduction ratio (reduction) : 78%, 65%, 61%, 50% Margin+ : 90 - 99%
Print Speed	Approx. 60 - 150 sheets per minute (Control panel: five steps variable, touch panel: 150 ppm)
Print Position Adjustment	Vertical : ± ¹⁹ / ₃₂ " (±15 mm) Horizontal : ± ³ / ₈ " (±10 mm)
Ink Supply	Full automatic (1000 ml per cartridge)
Master Supply/Disposal	Full automatic (approx. 220 sheets per roll)
Master Disposal Capacity	80 sheets
User Interface	LCD Touch Panel with Progress Arrow indicators, front-side operation
Optional Accessories	Auto Document Feeder AF-VI:II, Auto Document Feeder DX-1, Job Separator, Key Card Counter, Color Cylinder (Drum), Network Interface Card RISORINC-NET-D:G/GII, Special Paper Feed Kit, Stand, Document Storage Card DM-128CF, Wide Stacking Tray, RISO Color Separation Software CS-2000, RISO Controller PS7R
Power Source	MZ790U : 100V-120V / 220V-240V AC, 50/60Hz <7.3/3.0A>

Appendix

Dimensions

When in use :

$63\frac{3}{16}$ " (W) \times $28\frac{9}{16}$ " (D) \times $28\frac{3}{4}$ " (H) (1605 mm (W) \times 725 mm (D) \times 730 mm (H))

When in storage :

$39\frac{3}{4}$ " (W) \times $28\frac{9}{16}$ " (D) \times $28\frac{3}{4}$ " (H) (1010 mm (W) \times 725 mm (D) \times 730 mm (H))

Weight

Approx. $370\frac{1}{16}$ lb (168 kg)

Note:

- Please note that due to improvements and changes to the machine, some images and explanations in this manual may not correspond to your machine.
- The specifications are subject to change without prior notice.

RISO MZ770

Master-making/printing methods	High-speed digital master-making/full automatic stencil printing
Original Type	Book (22 lb (10 kg) or less), sheet
Original Size (max./min.)	When using the Stage Glass : $1^{15}/_{16}$ " \times $3^{9}/_{16}$ " (50 mm \times 90 mm) - $11^{11}/_{16}$ " \times 17" (297 mm \times 432 mm) When using Auto Document Feeder AF-VI:II (option) : $3^{15}/_{16}$ " \times $5^{13}/_{16}$ " (100 mm \times 148 mm) - $11^{11}/_{16}$ " \times 17" (297 mm \times 432 mm) When using Auto Document Feeder DX-1(option) : $4^{1}/_{8}$ " \times $5^{1}/_{16}$ " (105 mm \times 128 mm) - $11^{11}/_{16}$ " \times 17" (297 mm \times 432 mm)
Original Paper Weight	When using the Stage Glass : 22 lb (10 kg) or less When using the Auto Document Feeder AF-VI:II (option) : 13-lb bond (50 g/m ²) - 34-lb bond (128 g/m ²) When using Auto Document Feeder DX-1 (option) : 11-lb bond (40 g/m ²) - 34-lb bond (128 g/m ²) (When "Scanning Side -ADF" is set to "Back Side \rightarrow Simplex" or "Duplex \rightarrow Simplex" : 14-lb bond (52 g/m ²) - 28-lb bond (105 g/m ²))
Print Paper Size (max./min.)	When simultaneously 2-Color printing: $7^{3}/_{16}$ " \times $10^{1}/_{8}$ " (182 mm \times 257 mm) - $11^{11}/_{16}$ " \times 17" (297 mm \times 432 mm) When 1-Color printing (using Cylinder (Drum) 1): $3^{15}/_{16}$ " \times $5^{13}/_{16}$ " (100 mm \times 148 mm) - $11^{11}/_{16}$ " \times 17" (297 mm \times 432 mm) When 1-Color printing (using Cylinder (Drum) 2): $7^{3}/_{16}$ " \times $10^{1}/_{8}$ " (182 mm \times 257 mm) - $11^{11}/_{16}$ " \times 17" (297 mm \times 432 mm)
Paper Supply Capacity	1000 sheets (17-lb bond (64 g/m ²))
Print Paper Weight	13-lb bond (46 g/m ²) - 110-lb index (210 g/m ²)
Image Processing mode	Line, Photo (Standard/Portrait/Group), Duo, Pencil
Master-making Time (for A4/portrait/100% reproduction ratio)	Approx. 57 seconds (for dual-color print) Approx. 24 seconds (for single-color print (Cylinder (Drum) 1)) Approx. 34 seconds (for single-color print (Cylinder (Drum) 2))
Printing Area (max.)	$11^{7}/_{16}$ " \times $16^{1}/_{4}$ " (291 mm \times 413 mm)
Print Reproduction Ratio	Zoom : 50 - 200% Standard reproduction ratio (enlargement) : 163%, 141%, 122%, 116% Standard reproduction ratio (reduction) : 87%, 82%, 71%, 61% Margin+ : 90 - 99%
Print Speed	Approx. 60 - 150 sheets per minute (Control panel: five steps variable, touch panel: 150 ppm)
Print Position Adjustment	Vertical : $\pm^{19}/_{32}$ " (\pm 15 mm) Horizontal : $\pm^{3}/_{8}$ " (\pm 10 mm)
Ink Supply	Full automatic (1000 ml per cartridge)
Master Supply/Disposal	Full automatic (approx. 220 sheets per roll)
Master Disposal Capacity	80 sheets
User Interface	LCD Touch Panel with Progress Arrow indicators, front-side operation
Optional Accessories	Auto Document Feeder AF-VI:II, Auto Document Feeder DX-1, Job Separator, Key Card Counter, Color Cylinder (Drum), Network Interface Card RISORINC-NET:G/GII, Special Paper Feed Kit, Stand, Document Storage Card DM-128CF, Wide Stacking Tray, RISO Color Separation Software CS-2000, RISO Controller PS7R
Power Source	MZ770A : 100V-120V/220V-240V AC, 50/60Hz <7.3/3.0A>

Appendix

Dimensions

When in use :

$63\frac{3}{16}$ " (W) \times $28\frac{9}{16}$ " (D) \times $28\frac{3}{4}$ " (H) (1605 mm (W) \times 725 mm (D) \times 730 mm (H))

When in storage :

$39\frac{3}{4}$ " (W) \times $28\frac{9}{16}$ " (D) \times $28\frac{3}{4}$ " (H) (1010 mm (W) \times 725 mm (D) \times 730 mm (H))

Weight

Approx. $370\frac{1}{16}$ lb (168 kg)

Note:

- Please note that due to improvements and changes to the machine, some images and explanations in this manual may not correspond to your machine.
- The specifications are subject to change without prior notice.

Index

Symbols

* Key	22, 136
+ Key	22, 136
xKey	22, 136

Numerics

150ppm	113
2 Up	87, 93
2-Color Printing with 1 Original	46
2-Color Printing with 2 Originals	40

A

ADF Cover	270, 271
ADF Original Guide	20, 21
ADF Original Receiving Tray	20, 21
ADF Original Release Dial	269
ADF Original Release Lever	20, 269
ADF Semi-Auto	171, 174
ADF unit	20, 21, 56, 59
Admin.	173
Admin. Screen	29
Advanced Features	132
Area Specification Sheet	49
Auto 90°Rotation	175
Auto Clear	176
Auto Document Feeder	41
Auto Document Feeder AF-VI:II	20, 292
Auto Document Feeder Cover	21
Auto Document Feeder DX-1	21, 292
Auto Idling	42, 160, 177
Auto Page Renewal	177
Auto Print	28, 68
Auto Process Mode	174
Auto Shut-Off	176
Auto-Link	222
Auto-Process	63, 83
Auto-Process Indicator	83
Auto-Process Key	23

B

Base IP Address	175
Basic Process	37
Basic Screen	27
Beep Sound	177
Book Shadow	84

C

C Key	22, 44, 54, 60, 81, 83, 99, 136, 137, 171
Changing Output Directions	67
Checking Remaining Consumable Amount	242
CI Select	175
Cleaning	256
Clear All	67
Clock/Calendar	176
Closing the Paper Feed Tray	34
Closing the Paper Receiving Tray	36

Color Auto-Link	178
Color Cylinder (Drum)	250, 292
Color Mode	25
Combination	134, 137, 139, 141, 143, 144
Common Buttons	30
Computer Connection	13
Confidential	162
Configurable Functions (Link Mode)	232
Consumable Error	262, 266
Consumables	12
Contrast Adjustment	74
Control Panel	18, 22
Counter	19
Counter Display	169
Custom Paper Entry	175, 186
Cylinder (Drum) 1 and Cylinder (Drum) 2 Print Position Alignment	116

D

Data Information	201
Data-Map	27
Default Folder	174
Default Settings	173, 179
Density (Print Density)	114
D-Feed Check	119
Direct Access	27
Direct Print	63
DirectAccess Entry	173, 182
Display	18, 22, 24
Display Adjustment	173
Display Priority	173
Displayed Language	173
Disposing of Consumables	253
Document Storage Card	292
Dot Process	72
Double Feed Check	174
Dual-Color Printing	40
Duo	70
Duplex Interval	178
Duplex Printing	235

E

Easy 2Color	46
Energy Saving Mode	176
Error Messages	262
Ex. Reserve Period	159, 176
Extended Paper	188

F

Feed Tray Descent Button	18, 34
Feed Tray Paper Guide	18
Flanges	244
Folder Renaming	175
Format	203
Free	78, 80

Front Cover	19
Function and Name of Each Part	18
Functions Area	27
Functions Screen	29

G

Gauge Cover	41, 52, 56, 59
Group	132

H

Hand Writing--1	47
Hand Writing--2	48
High Speed	113
Humidity Range	11

I

i Information	27, 242
Icons Used in This Manual	8
Idling Action	160
Image Processing	173
Image Processing Mode	70
Initial Screen	24
Ink	246, 253
Ink Cartridge	19, 246, 253
Ink Cartridge Cap Holder	19, 247
Ink Handling	12
Ink Information Input	279
Ink Saving	86
Ink/Master Holder	292
Installation	10
Installation Error	262, 266
Installation Location	10
Interval	120
Irregular Fitter	175

J

Jam Error	262
Job	28
Job Information Display	28
Job Memory	150, 151, 153, 155, 157
Job Operation Area	28
Job Separation	174
Job Separator	135, 292
Jump Wing Control	122, 123, 174

K

Key Card Counter	292
------------------------	-----

L

Line	70
Link Info Refresh	178
Link Mode	26, 223, 228
Link Properties	178, 224
Linked Printer	178, 222
Linked Printer Setup List	224
Link-Free Volume	178
Loading Paper	33

M

Machine Handling	11
Maintenance	256
Maintenance Call	273
Malfunctions	282
Margin+	78, 79
Margin-Plus Rate	176
Margins	17
Master	254
Master core	244, 253
Master Disposal Box	248
Master Disposal Box 1	18
Master Disposal Box 2	19
Master Disposal Box Handle	248
Master Guide Flap	19, 244
Master Information Input	280
Master Making Unit	243
Master Making Unit Cover	19, 243
Master Making Unit Cover Lever	243
Master Making Unit Handle	243
Master Making Unit Lever	19
Master Making Unit Release Button	19, 243
Master Making Unit Removal Cover	19, 243
Master Making Unit Removal Lever	19, 243
Master Replacement	243
Master Roll	19
Master Roll Holder	19, 244
Master-Making Key	23
Materials Not to Be Printed	17
Max. Scan	101
Maximum Printing Area	17
Message	262
Message Area	27
Minimum Print Q'ty	177
Mode Key	22
Multi-Page Mode	133, 137, 139, 141, 143, 144
Multiple Paper Feed Detection	119
Multi-Up function	87, 94
Multi-Up Print	87
Multi-Up Tickets	90, 96

O

OneSide MasterMake	98
Online Auto-Link	178
OP Auto Process	174
Operation Environment	11
Operation Pattern Display	9
Operation Safety Guide	11
Optional Accessories	292
Optional Device Area	28
Optional Device Error	262, 264
Optional Functions (Linked Printer)	231
Original	16
Original Guide	41, 56, 59
Original Margin	17
Original Position Indicator	115

Original Restrictions	17	Printing from Paper Document	27, 40
Original Scan Density	77	Printing with 1-Color	58
Overlay	208	Program	132
P		Program Key	22
P Key	22	Progress Bar	23
Page Orientation	178	Proof copy	44, 54, 60, 65, 99, 118
Paper Arranger	19, 35	Proof Key	23, 118
Paper Ejection Adj	174	Protect	176, 190
Paper Ejection Wing	122	PS7R Information	175
Paper Feed Pressure Adjustment Lever	18, 34	R	
Paper Feed Tray	18, 33, 34	Receiving Tray Paper Guides	19, 35, 36
Paper Guide	33	Red Color	47
Paper Jam Error	262, 263, 269	Rename screen	142
Paper Jumping Wing	19	Renew Page	28, 67, 102
Paper Receiving Tray	19, 35, 36	Replacing Batteries	263, 273
Paper Recommendations	14	Replacing Consumables	242
Paper Size	82	Reproduction Size	174
Paper Stopper	19, 35, 36	Reservation	159
Pencil	70	Reserve Period	176
Photo	70	Reset Key	23
Photo Contrast	74	RISO Controller PS7R	292
Photo Gradation	75	RISO PRINTER Network Interface Card	
Photo (Group)	70	RISORINC-NET-D:G/GII	292
Photo (Portrait)	70	S	
Photo (Standard)	70	Safety Guide	10
Power Connection	10	Scan Mode	26, 196
Power Switch	19, 32	Scanner Glass	258
Power-OFF Schedule	176	Scanning Contrast	77, 174
Pressure Roller	259	Scanning Interval	176
Preview	28, 67	Scanning Side -ADF	164, 174
Print Colors	178	Selecting a Mode	25
Print Cylinder (Drum)	250	Selections	29
Print Cylinder (Drum) 1	19	Selections Entry	173, 182
Print Cylinder (Drum) 2	19	Semi-Auto (Master)	63, 68
Print Cylinder (Drum) Handle	19, 250	Semi-Auto (Print)	63, 68
Print Cylinder (Drum) Release Button	19, 250	Separation Hook	259, 271
Print Cylinder (Drum) Replacement	250	Separation Sheet	49, 56
Print Density	22, 114, 174	Service Call Error	262, 263
Print Density Adjustment Keys	22, 114	Setting the Paper Receiving Tray	35
Print Density Indicator	22, 114	Single Page Mode	132, 136, 139, 141, 143, 144
Print Key	23	Size and Weight Restrictions	14, 16
Print Paper	14, 34	Skip Page	28, 67
Print Paper Handling	15	Special Paper Ctrl	122
Print Position Adjustment	115	Special Paper Feed Kit	292
Print Position Adjustment Keys	22	Specifications	293
Print Position Center Key	115	Specified Area	48
Print Position Indicator	22	Speed (print speed)	112
Print Quantity Display	22	Stage Cover	18
Print Quantity Keys (0 to 9 Keys) ..	22, 44, 54, 60, 83, 99	Stage Cover Pad	18, 257
Print Speed	22, 112, 174	Stage Glass	18, 41, 257
Print Speed Adjustment Keys	22, 112	Stamp	210, 215
Print Speed Indicator	22, 112	Stamp Data	175
Printer Exterior	260	Stand	292
Printing Cautions	17	Standard Ratio	78, 79
Printing from Computer	28, 63		

Start Key	23
Start-Up Screen	173
Status Area	27, 28
Stock Management	177
Stop Key	23
Stop Timing	63, 68
Storage Memory	194, 204
Storing Environment	15
Sub Tool Bar	178

T

Tab Area	27, 28
Temperature Range	11
Text and Photo (Image Processing mode)	70
Text (Image Processing mode)	70
The Screens and their Various Stages	24
Thermal Print Head	19, 257
Tips for Better Paper Feeding	15
Tone Curve	75
Tool Bar Position	178
Troubleshooting	262

U

Usage Status	169
--------------------	-----

W

Wake-Up Key	23
Warning Messages	274
White Sheet	258

Z

Zoom	78, 81
------------	--------

To Administrator

Canceling the Protect Setting

Cancellation of the “Protect” setting should be always done by the administrator.

Important!:

- To attach more importance to security, cut out this page, which should be stored by the administrator.

1 Touch [Admin.] on the Basic Screen for each mode.



2 Touch [OK].



3 Touch greyed-out [Protect].

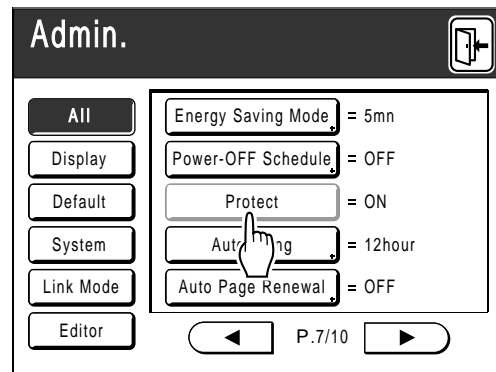

4 Remove the Master Disposal Box.

Remove either one of two Master Disposal Boxes.
 ☞ p.248

5 Touch [Protect] again after removing the Master Disposal Box.

The “Protect” setting is cancelled.

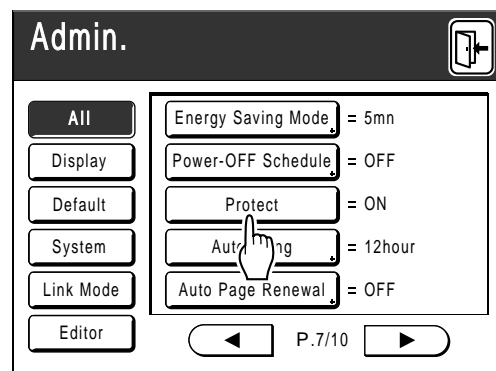

After confirming that the display indicates “OFF”, set the Master Disposal Box to the original position.

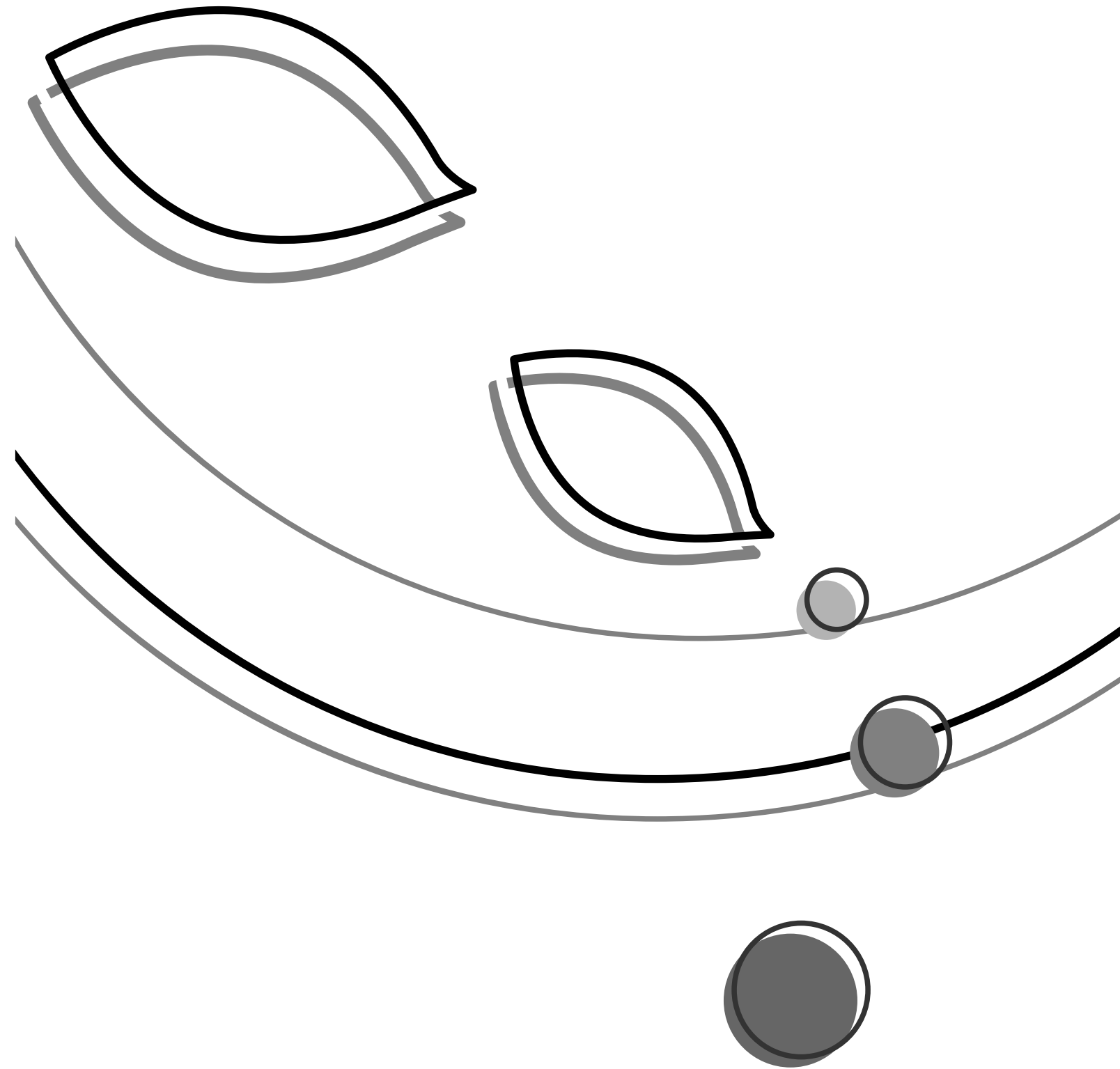



As an **ENERGY STAR**® Partner, RISO KAGAKU CORP. has determined that this product meets the **ENERGY STAR**® guidelines for energy efficiency.

For MZ990 and MZ790U Models Only

Duplicator

Model: MZ990 and MZ790U

RFID System

Model: 045-50025

Contains FCC ID: RPARFA3A

This device complies with Part 15 of the FCC Rules. Operation is subject to the following two conditions: (1) this device may not cause harmful interference, and (2) this device must accept any interference received, including interference that may cause undesired operation.

The user is cautioned that unauthorized changes or modifications not approved could the user's authority to operate the equipment.

NOTE: This equipment has been tested and found to comply with the limits for a Class B digital device, pursuant to part 15 of the FCC Rules. These limits are designed to provide reasonable protection against harmful interference in a residential installation. This equipment generates, uses and can radiate radio frequency energy and, if not installed and used in accordance with the instructions, may cause harmful interference to radio communications. However, there is no guarantee that interference will not occur in a particular installation. If this equipment does cause harmful interference to radio or television reception, which can be determined by turning the equipment off and on, the user is encouraged to try to correct the interference by one or more of the following measures:

- Reorient or relocate the receiving antenna.
- Increase the separation between the equipment and receiver.
- Connect the equipment into an outlet on a circuit different from that to which the receiver is connected.
- Consult the dealer or an experienced radio/TV technician for help.

Contains IC: 4819A-RFA3A

Operation is subject to the following two conditions: (1) this device may not cause interference, and (2) this device must accept any interference, including interference that may cause undesired operation of the device.

This Class B digital apparatus complies with Canadian ICES-003.

Cet appareil numérique de la classe B est conforme à la norme NMB-003 du Canada.

Perchlorate Material-special handling may apply.

See www.dtsc.ca.gov/hazardouswaste/perchlorate

This product may contain certain substances which are restricted when disposed.

Therefore, be sure to consult your contracted service dealer.

Warning

For MZ770A Model Only

This is a Class A product. In a domestic environment this product may cause radio interference in which case the user may be required to take adequate measures.