

RISO EZ Series

User's Guide

590/570



RISO



As an **ENERGY STAR**® Partner, RISO KAGAKU CORP. has determined that this product meets the **ENERGY STAR**® guidelines for energy efficiency.

For EZ590U Model Only

Duplicator

Model: EZ590U

RFID System

Model: 444-59008

Contains FCC ID: RPARFOM5

This device complies with Part 15 of the FCC Rules. Operation is subject to the following two conditions: (1) this device may not cause harmful interference, and (2) this device must accept any interference received, including interference that may cause undesired operation.

The user is cautioned that unauthorized changes or modifications not approved could the user's authority to operate the equipment.

NOTE: This equipment has been tested and found to comply with the limits for a Class B digital device, pursuant to part 15 of the FCC Rules. These limits are designed to provide reasonable protection against harmful interference in a residential installation. This equipment generates, uses and can radiate radio frequency energy and, if not installed and used in accordance with the instructions, may cause harmful interference to radio communications. However, there is no guarantee that interference will not occur in a particular installation. If this equipment does cause harmful interference to radio or television reception, which can be determined by turning the equipment off and on, the user is encouraged to try to correct the interference by one or more of the following measures:

- Reorient or relocate the receiving antenna.
- Increase the separation between the equipment and receiver.
- Connect the equipment into an outlet on a circuit different from that to which the receiver is connected.
- Consult the dealer or an experienced radio/TV technician for help.

Contains IC: 4819A-RFOM5

Operation is subject to the following two conditions: (1) this device may not cause interference, and (2) this device must accept any interference, including interference that may cause undesired operation of the device.

This Class B digital apparatus complies with Canadian ICES-003.

Cet appareil numérique de la classe B est conforme à la norme NMB-003 du Canada.

Perchlorate Material-special handling may apply, See www.dtsc.ca.gov/hazardouswaste/perchlorate

This product may contain certain substances which are restricted when disposed.

Therefore, be sure to consult your contracted service dealer.

Warning

For EZ570A and EZ570AN Models Only

This is a Class A product. In a domestic environment this product may cause radio interference in which case the user may be required to take adequate measures.

MASCHINENLÄRMINFORMATION

Maschinenlärminformations-Verordnung 3. GSGV:

Der höchste Schalldruckpegel beträgt 70 dB(A) oder weniger gemäß EN ISO 7779.

Hinweis :

Das Gerät ist nicht für die Benutzung am Bildschirmarbeitsplatz gemäss BildscharbV vorgesehen.



Countries of intended use

Austria/Belgium/Denmark/Finland/France/Germany/Greece/Iceland/Ireland/
Italy/Luxembourg/Netherlands/Norway/Portugal/Spain/Sweden/Switzerland/U.K.

- This product contains RFID (Radio Frequency Identification) System.

Riso shall not be responsible for any damage or expense that might result from the use of this manual. As we are constantly improving our products, the machine may differ in some respects from the illustrations used in this manual.

Riso shall not be liable for any direct, incidental, or consequential damages of any nature, or losses or expenses resulting from the use of this product or included manuals.

 Caution:

- Make sure to read the important operational safety information.
- Store this manual close-by, and fully acquaint yourself with the printing machine.

RISO is a registered trademark of RISO KAGAKU CORPORATION in Japan and other countries.

RISO iQualitySystem™ is a trademark of RISO KAGAKU CORPORATION.



is a trademark of RISO KAGAKU CORPORATION.

- The information contained in this document is subject to change without notice.

Copyright © 2007 RISO KAGAKU CORPORATION

Contents

Welcome to the EZ5 Series Model	7
About This User's Guide.....	7
Icons Used in This Manual	8

Before Starting to Use **10**

Safety Guide - Installation	10
Installation	10
Power connection	10
Safety Guide - Handling and Operation.....	11
Operation Environment.....	11
Machine Handling	11
USB Flash Drive	11
Consumables.....	12
Ink Handling.....	12
Connection with a Computer	13
Connection Method	13
Software Installation	14
Paper Recommendations	15
Size and Weight Restrictions.....	15
Tips for Better Paper Feeding	16
Storing Environment	16
Originals	17
Size and Weight Restrictions.....	17
Maximum Printing Areas and Margins.....	18
Materials Not to Be Printed	18

Getting Acquainted **20**

Function and Name of Each Part	20
Control Panel.....	22
Display.....	24
The Screens and their Various Stages.....	24
Basic Screen Layout.....	28
Basic Process.....	30

Basic Operations **32**

Preparing to Print.....	32
Setting up the Paper Feed Tray and Loading Paper	32
Setting up the Paper Receiving Tray	35
Printing from a Paper Document or Book.....	37
Printing from a Computer Data [Direct Print] [USB Job List]	43
Printing Computer Data [Direct Print]	43
Printing USB Data [USB Job List].....	46
Changing Output Directions	49
Changing Stop Timing	51

Functions for Master-Making	52
Selecting Image Processing Mode [Image]	52
Selecting Scanning Contrast for the Original [Contrast]	54
Enlarging/Reducing Originals [Standard Ratio] [Margin+] [Free] [Zoom]	55
Enlargement and Reduction by Standard Ratio [Standard Ratio] [Margin+] [Auto]	56
Enlargement/Reduction of a Changed Aspect Ratio [Free]	58
Enlarging and Reducing with the Zoom Function [Zoom]	59
Using Custom-Sized Paper [Paper]	60
Automatic Printing [Auto-Process]	61
Processing Photos with Dot Screen [Dot Process]	62
Saving Ink [Ink Saving]	64
Printing Multiple Originals on One Sheet [2 Up] [Multi-Up Print]	65
Original Orientation and Print Results	66
Margin	69
Orientation of Print Paper	69
Multi-Up Interval	69
2 Up Operation	70
Operation for Multi-Up Printing	72
Operation for Multi-Up Tickets	74
Printing from Bound Documents [Book Shadow]	77
Cutting the Top Margin of the Original and Printing [Top Margin]	79
Adjusting the Side Margins of the Master [Side Margin]	81
Checking the Print Image Prior to Making Master [Preview]	83
Actions Available on the Preview Screen	84
Operation for Preview	84
Making a Master that Utilizes the Maximum Printing Area [Max. Scan]	86
Functions for Printing	88
Changing the Print Speed [Print Speed Adjustment]	88
Adjusting the Print Density [Print Density Adjustment]	89
Adjusting the Print Position [Print Position Adjustment]	90
Vertical (Up/Down) Adjustment	90
Horizontal (Left/Right) Adjustment	91
Printing Proof Copies [Proof]	92
Extending the drying time [Interval]	93
Paper Feed/Output Settings for Special Paper and Printing Types [Jump Wing Control] [Special Paper Ctrl]	95
Setting the Jump Wing Control [Jump Wing Control]	96
Retrieving Settings from the Parameter List	97
Saving settings in the Parameter List	99
Making changes to Special Paper Ctrl Setting	102
Clearing Special Paper Ctrl Settings	103

Advanced Features	104
Setting Up User Management [User Management].....	104
Selecting Recognition and Identification System.....	107
Setting Up the Management Level.....	109
Registering Administrator/Users.....	110
Changing Administrator/User Registration.....	117
Clearing User Registration.....	119
Renaming Groups.....	121
Clearing All User Counters.....	123
Protecting Confidential Documents [Confidential].....	124
Automatic Sorting Into Groups [Program].....	125
Setting Up for Programed Printing.....	127
Retrieving a Program.....	129
Saving Programs.....	130
Renaming a Program.....	132
Clearing Programs.....	134
Making changes to Stored Programs.....	135
Using Job Memory Functions [Job Memory].....	136
Storing Job Memory.....	137
Renaming a Job Memory.....	139
Retrieving a Job Memory and Printing.....	141
Clearing Job Memory.....	143
Extending the Reserve Period [Reservation].....	145
Idling Action [Idling Action].....	146
Reproducing the Master [Renew Page][Auto Page Renewal].....	147
Using Page Renewal.....	147
Using Auto Page Renewal.....	149
Proof and Print (with the ADF unit (Option) installed) [ADF Semi-Auto].....	150
Showing Usage Status [Meter Display].....	152
Rotating the Original 180 Degrees to Make a Master [Rotate].....	153
Checking User Counters [ID Counter Report].....	154
Outputting the Counter Report.....	155
Setting Up the Monthly Reminder.....	156
Customizing the Direct Access Area [My Direct Access].....	158
Changing Default Settings [Admin.].....	161
Configurable Functions.....	161
Customizing the Default Settings.....	168
Setting Up Direct Access Area and Selections Tab [Direct Access Entry] [Selections Entry].....	171
Registering a Custom Paper Size [Custom Paper Entry].....	174
Entering sizes and changing names.....	174
Clearing a Custom Paper Size.....	177
Keeping Masters Secure After Printing.....	178
Preventing Leaks of Masters After Creation or Disposal [Protect].....	179

Storing Original Data and Use Method	182
Converting Hard-copies into Stored Data (Scan Mode)	184
Scanning an Original	184
Setting Data Information	186
Specifying Stored Size	188
Retrieving Stored Data and Printing [Storage Memory][USB Job List].....	189
Retrieving Stored Data	189
Using the Storage Retrieve Screen/USB Job List Retrieve Screen	192
Changing the Data Order	194
Overlaying Stored Data onto a Print Job [Overlay].....	195
Copying/Moving Stored Data.....	197
Replacing Consumables	200
Check for Remaining Amount of Consumables.....	200
Replacing the Master Roll	202
Replacing the Ink Cartridge	205
Emptying the Master Disposal Box	207
Replacing the Print Drum (Cylinder) (Color (colour) Change).....	209
Removing the Print Drum (Cylinder).....	209
Installing the Print Drum (Cylinder).....	211
Disposal of Depleted Consumables	212
Maintenance	214
Cleaning	214
Thermal Print Head	215
Glass Platen and Platen Cover Pad	215
Scanner Glass and White Sheet of ADF unit (Option)	216
Pressure Roller	216
The Exterior	217

Troubleshooting **218**

When a Message Displays 218
 Error Message Layout 218
 Pop-Up Message Layout 226
 Consumable Information Screen 232
Troubleshooting..... 235

Appendix **244**

Optional Accessories 244
Specifications 245
Index..... 248

Welcome to the EZ5 Series Model

Thank you for your purchase of this printing machine.

The EZ5 series is a digital duplicator with an LCD display. It features an easy-to-use Touch Screen which displays only the relevant buttons for any given task. With an interactive guidance system, highly-sophisticated printer settings can be made with ease.

This manual shows you the machine's basic and advanced operations using various functions. It also contains cautionary notes, usage and replacement information on consumable supplies and troubleshooting tips.

Please read this manual carefully before using this machine. Reference at any time as needed for more tips and ideas.

About This User's Guide

This machine comes with the following four user's guides.

◆ RISO EZ590/570 User's Guide (this manual)

This user's guide explains the machine's operations via various functions and handy tips. It also contains user cautions, information on storing and changing consumables, and troubleshooting procedures.

◆ RISO Editor User's Guide

This user's guide explains the RISO Editor functions.

◆ RISO Printer Driver User's Guide (included as a PDF file on the provided CD-ROM)

This user's guide explains the procedures for printing from a computer.

◆ RISO Utility Software User's Guide (included as a PDF file on the provided CD-ROM)







This user's guide explains how to use the software of the "RISO COPY COUNT VIEWER" and "RISO USB PRINT MANAGER".

Icons Used in This Manual

The following icons are used in this manual.

About the notation

The following icons are used throughout the document.

-  **WARNING:** Ignoring this warning could cause death or serious injury.
-  **Caution:** Ignoring this caution could cause injury or damage to property.
- Important!:** Indicates items that require special attention or that are prohibited actions. Read carefully and follow the directions as instructed.
- Note:** Gives you useful information.
- Tip:** Gives you additional hints for more convenience.
-  Indicates a reference page.
- [] Indicates a button or item name on the LCD display.
-  Indicates which button to touch on the LCD display.
-  Indicates the original document.
-  Indicates printed copies.

The notation for Operational Instructions and Function Descriptions

The following conventions are used to explain functions and operations.

Functions for Master-Making

Selecting Image Processing Mode [Image]

In order to make a master best suited for the original document, select an appropriate mode depending on original content (only text, photo, or both of them).

Note:

- Default Image Processing mode can be set on the Admin. screen. p.165

1 Touch [Image] on the Master Making Basic Screen.



2 Select the appropriate Image Processing mode for the original.



- [Line]: Only text contained, e.g., text document, newspaper
- [Photo]: Only photos contained
- [Duo]: Both text and photos contained
- [Pencil]: Pencil drawings or lightly printed documents

52 Selecting Image Processing Mode [Image]

Touch [Photo], [Duo] or [Pencil] to set detailed settings.



3 Touch [OK].



The following screen appears.



Returns to the Master Making Basic Screen. Image Processing mode is updated.

53 Selecting Image Processing Mode [Image]

1) Chapter Title

2) Operation Procedure
The operational procedures are outlined in steps. Follow these steps.

3) Display
Shows the screen as seen on each step.

About the content of this manual and the illustrations

- The illustrations included in this document depict the EZ570A model in most cases.
- Displays are illustrated as if currently activated. Some buttons presented in this manual may not be available by default setting, or when the optional device is not installed.
- The optional Auto Document Feeder AF-VI:II is referred to as the “ADF unit (Option)”.

Before Starting to Use

Safety Guide - Installation

This section describes the precautions to be observed when installing the machine. Read this section before installing the machine.

Note:

- Your dealer will help you to determine a proper location for the machine at the time of delivery.

Installation

▲WARNING:

- Place the machine on the dedicated stand for this model or on a flat and stable surface (maximum of 10 mm ($\frac{3}{8}$ inches) differential allowed). Injury might occur if the machine falls.
- Install the machine in a well-ventilated area. Failure to do so may result in serious health problems.

▲Caution:

- Install the machine near the electrical outlet to avoid using an extension cord between the machine and the electrical outlet. If an extension cord is absolutely required, do not use one longer than 5 m (15 feet).
- Allow at least 10 cm (4 inches) or more of clearance behind the machine so that you can unplug the machine in case of technical difficulties.
- Keep the machine away from dusty environments. Failure to do so may result in fire.

Important!:

- Avoid installing the machine in the locations listed below. Failure to observe this precaution may lead to machine failure.
 - Locations with exposure to direct sunlight, such as locations close to windows (Curtain all windows that might expose the machine to direct sunlight)
 - Locations that are subject to sudden changes in temperature
 - Extremely hot and humid locations or cold and dry locations
 - Heated locations
 - Locations exposed to direct cold air, direct hot air, or direct radiant heat

Power connection

▲WARNING:

- Do not overload the electrical outlet or extension cord, nor damage the power cord by placing heavy objects on it or pulling or bending it. This can result in fire or electric shock.
- Do not pull the power cord but hold the plug itself when unplugging it. This can damage the cord and result in fire or electric shock.
- Do not plug or unplug the power cord if your hands are wet. This can result in electric shock.

▲Caution:

- Pull out the power cord plug from the electrical outlet more than once a year and clean the prongs of the plug and their surroundings. Dust collected on these areas can result in fire.

Important!:

- Check the power cord and plug for poor connections. Plug the power cord securely into a nearby electrical outlet.
- Be sure to turn off the POWER switch when connecting or disconnecting a cable.
- Do not touch the POWER switch on the upper part of the AC inlet (power cord connection). Changing the POWER switch setting by mistake will cause damage.

Safety Guide - Handling and Operation

This section describes the precautions to be observed when handling the machine. Read this section before operating the machine.

Operation Environment

Important!:

- Operate the machine under the following appropriate environment conditions.
Temperature range: 15° C to 30° C (59° F to 86° F)
Humidity range: 40% to 70% (noncondensing)

Machine Handling

⚠ WARNING:

- Do not place water containers or metallic objects on the machine. Fire or electric shock may occur if water or metallic objects fall into the machine.
- Do not insert any metallic material or flammable substance into the machine through any opening. This can result in fire or electric shock.
- Do not remove machine covers. Exposing internal parts may result in electric shock.
- Do not disassemble or rebuild the machine by yourself. This can result in fire or electric shock.
- If the machine emits excessive heat, smoke or foul odor, immediately turn off the POWER, unplug the power cord and contact your service representative. Failure to do so can result in fire or electric shock.
- If something drops inside the machine, immediately turn off the POWER, unplug the power cord and contact your service representative. Failure to do so can result in fire or electric shock.
- Never stick your hands or fingers in the openings of the machine during operation.
- Keep loose clothing or long hair away from moving parts to avoid becoming entangled.
- Do not place heavy objects on the machine. The objects might fall and cause injury.
- Contact your service representative before moving the machine.

⚠ Caution:

- Do not open any covers or move the machine during operation.
- Unplug the power cord, if you do not use the machine for a long time.
- The machine has precision parts and driving parts inside. Do not handle the machine in other ways than described in this manual.
- Do not apply any shock to the machine.

Important!:

- Do not unplug the power cord or turn off the power during operation.
- Be sure to open and close all machine covers gently.

USB Flash Drive

Important!:

- Use a USB Flash Drive to store large volumes of data. Depending on the types of USB Flash Drive, the machine does not work properly.
- When connecting or disconnecting the USB Flash Drive, follow the proper procedures.
- We cannot guarantee data saved in the USB Flash Drive against loss caused by accidents or unforeseen events. We recommend that you use your computer to make back-up copies of any important documents.

Consumables

Important!:

- For ink and Master Roll, it is recommended to use the products specified by RISO.
- Store consumables such as Master Roll and ink properly.
Do not store consumables in the following places:
 - Locations that are subject to direct sunlight or bright locations that are close to windows
(If there is no other choice, curtain the window.)
 - Locations that are subject to rapid changes in temperature
 - Extremely hot and humid locations or extremely cold and dry locations

Ink Handling

Caution:

- If ink gets into your eyes, flush it out immediately with plenty of water. If irritation continues, seek medical attention.
- If ink comes into contact with your skin, wash it off thoroughly using soap.
- Allow plenty of ventilation during printing.
- If you feel unwell during use, seek medical advice.
- Only use the ink for printing purposes.
- Keep the ink out of the reach of children.

Connection with a Computer

You can directly send data from a connected computer to the machine as an original for printing. Because digital data itself is used for making a master, the finish of prints becomes outstanding.

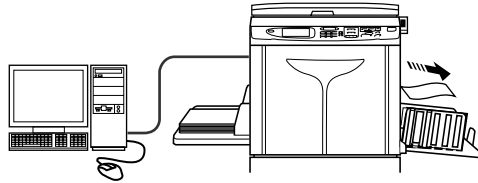

Connection Method

Important!:

- Before making the USB connections, turn on both the machine and computer, and wait until the initial screen is displayed.
- Before making the Ethernet connections, turn off both the machine and computer.
- The maximum allowable voltage for USB connector input and output is 5 V.

◆ One-to-one connection with a Windows PC

- Cable:
USB cable
3m (10 feet) Hi-Speed USB

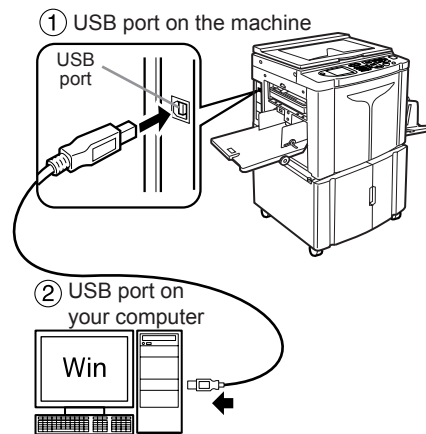

◆ Network connections

- Cable:
Ethernet cable
Shielded cable that supports 10BASE-T
or 100BASE-TX

Note:

- The RISO Network Card (Option) is required.

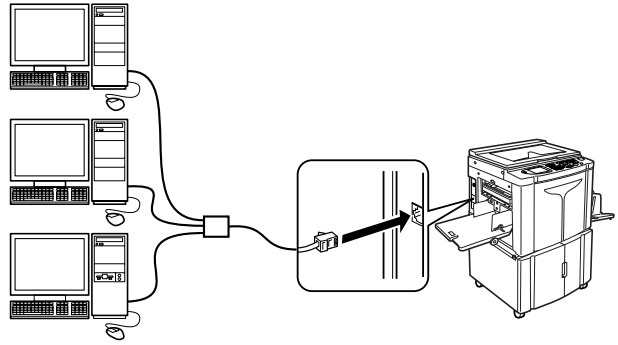

Software Installation

Before printing from a computer connected to the machine via a USB cable, the RISO printer driver must be installed. Before printing from a computer connected to the machine via a network, both the RISO printer driver and RISO Network Card must be installed. Refer to the Printer Driver User's Guide and RISO Network Card User's Guide for instructions on installation.

Note:

- RISO Network Card is an option.
The software supplied with this machine is as follows:

◆ RISO Printer Driver

◆ RISO Utility Software

The software package includes the "RISO COPY COUNT VIEWER" and "RISO USB PRINT MANAGER".

- "RISO USB PRINT MANAGER"
Application that manages the original data stored in the USB Flash Drive on the computer.
- "RISO COPY COUNT VIEWER"
Application that manages the counter data (number of prints, masters, etc.) output to the USB Flash Drive on the computer.

Paper Recommendations

Size and Weight Restrictions

The table shows the specifications of the usable print paper.

Usable Printing Paper	
Size	Weight
100 mm × 148 mm (3 ¹⁵ / ₁₆ " × 5 ²⁷ / ₃₂ ") to 310 mm × 432* mm (12 ³ / ₁₆ " × 17")	46 g/m ² (13-lb bond) to 210 g/m ² (110-lb index)

*The machine can print (feed) paper up to 555 mm (13.9") long by setting the "Custom Paper Entry". [p.174](#), [p.176](#)

Important!:

- Even when using paper whose sizes and weight are supported by the machine, it may not pass through the machine depending on such factors as the paper quality, ambient conditions, and storage conditions. Keep this in mind when using the machine. For more information, consult your dealer.

Do not use the following types of paper, as they can cause jams or misfeeds:

- Extremely thin paper (less than 46 g/m² (13-lb bond))
- Extremely thick or heavy paper (greater than 210 g/m² (110-lb index))
- Wrinkled, curled, folded, or torn paper
- Chemically treated or coated paper (such as thermal or carbon paper)
- Paper having a sticky section or holes (such as an envelope and label paper)

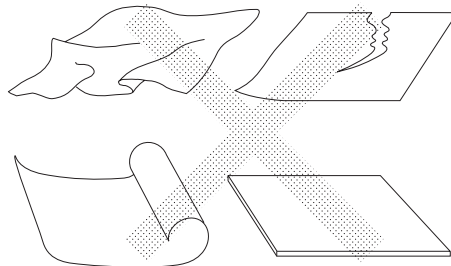

Note:

- Paper with a horizontal grain direction can cause problems with paper supply. Use paper with a vertical grain direction.

RISO does not assure that paper outside the above specifications pass through the machine and can be used for printing.

Tips for Better Paper Feeding

To prevent paper jams and misfeeds, follow the directions below:

- When using standard or light-weight paper, set the Paper Feed Pressure Adjustment Lever to “NORMAL” (✕). Then open all four Paper Arrangers. [p.33](#), [p.35](#)
- When using thick paper (such as card stock), set the Paper Feed Pressure Adjustment Lever to “CARD” (⊗), and open the two inner Paper Arrangers. [p.33](#), [p.35](#)
- When using slippery paper, set the Paper Feed Pressure Adjustment Lever to “CARD” (⊗). [p.33](#)
- Slide the Feed Tray Paper Guides, Receiving Tray Paper Guides, and Paper Stopper to fit the paper size. [p.32](#), [p.35](#)
- Use flat printing paper that is free of folds. If curled paper is unavoidable, place the printing paper so that the inner curled part faces down.
- Paper may stick to the drum (cylinder) surface if the top margin is too narrow on the original or if the upper portion of the original uses a large amount of ink. To solve this problem, lower the print position to provide a wider top margin or reverse the top and bottom of the original. Then restart printing from the beginning.

Storing Environment

Store printing paper in a level, dry area. Storing the paper in an excessively humid area can result in paper jams or poor print quality.

After unpacking printing paper, keep the remaining paper wrapped and store it in a moisture-proof box. It is highly recommended to put silica gel in the paper storage box.

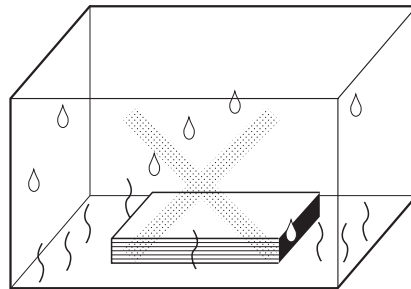

Originals

Size and Weight Restrictions

Usable originals are as follows.

Using the Glass Platen			Using the ADF unit (Option)	
Size (EZ590)	Size (EZ570)	Weight	Size	Weight
50 mm × 90 mm (1 ³¹ / ₃₂ " × 3 ⁹ / ₁₆ ") to 280 mm × 432 mm (11" × 17")	50 mm × 90 mm (1 ³¹ / ₃₂ " × 3 ⁹ / ₁₆ ") to 297 mm × 420 mm (11 ¹¹ / ₁₆ " × 16 ¹⁷ / ₃₂ ")	Max. 10kg (22 lb)	100 mm × 148 mm (3 ¹⁵ / ₁₆ " × 5 ²⁷ / ₃₂ ") to 310 mm × 432 mm (12 ³ / ₁₆ " × 17")	50 g/m ² (14-lb bond) to 128 g/m ² (34-lb bond)

- Originals are scanned according to the size of paper placed on the Paper Feed Tray when masters are made; for the same width, the positions of the Feed Tray Paper Guides.
When the placed paper is smaller than an original, not the entire original will be scanned.
When the placed paper is larger than an original, dirt on the glass or shade of the original, for example, may result in unexpected dirt in the area beyond the size of the original.
- Bound originals can also be used on the Glass Platen.
- You can feed automatically up to 50 original sheets when using the ADF unit (Option).
(When originals of 80 g/m² (21-lb bond) or less are used)

Note:

- Use the Glass Platen when printing the following originals:
 - Patched or worn originals
 - Wrinkled, curled, folded, or torn originals
 - Transparent originals (such as tracing paper or OHP transparencies)
 - Chemically treated originals (such as thermal or carbon paper)
 - Originals with correction fluid or glue
 - Extremely thin originals (less than 50 g/m² (14-lb bond))
 - Extremely thick originals (greater than 128 g/m² (34-lb bond))
 - Heavy drawing paper
 - Originals with staples or clips
- If an original wrinkled, curled, or creased flatten it thoroughly so that the original can be pressed directly onto the Glass Platen during processing.
- If correction fluid or glue is used on an original, thoroughly dry it before placement.
- For an original patched with thick paper, the shade of the patched paper may also be printed.

Maximum Printing Areas and Margins

The maximum printing areas are as follows.

Model	Maximum Printing Area	Usable Maximum Print Paper Size
EZ590	291 mm × 425 mm (11 ⁷ / ₁₆ " × 16 ³ / ₄ ")	310 mm × 432 mm (12 ³ / ₁₆ " × 17")
EZ570	291 mm × 413 mm (11 ⁷ / ₁₆ " × 16 ¹ / ₄ ")	

Important!:

- No matter which size of originals is printed, the margins indicated on the figure are required for the originals. Reduce the original if necessary to fit it inside of the margins. Place an original so that its end having a 5 mm (³/₁₆") margin at least comes to the left of the Glass Platen or the ADF unit (Option).

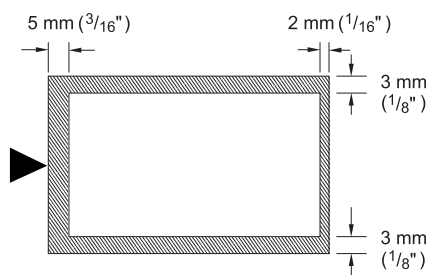

Materials Not to Be Printed

Do not use the machine in any manner which violates the law or infringes on established copyrights, even when making copies for personal use. Consult your local authorities for further details. In general, use discretion and common sense.

Getting Acquainted

Function and Name of Each Part

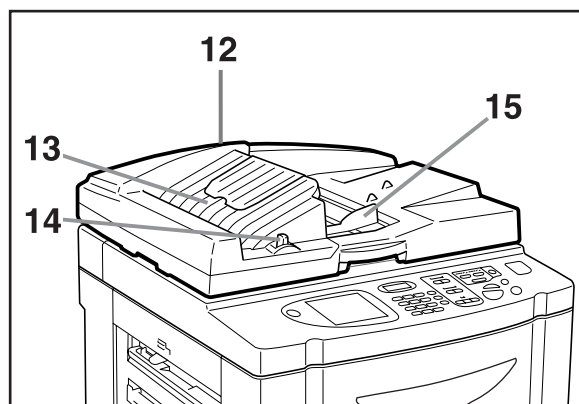
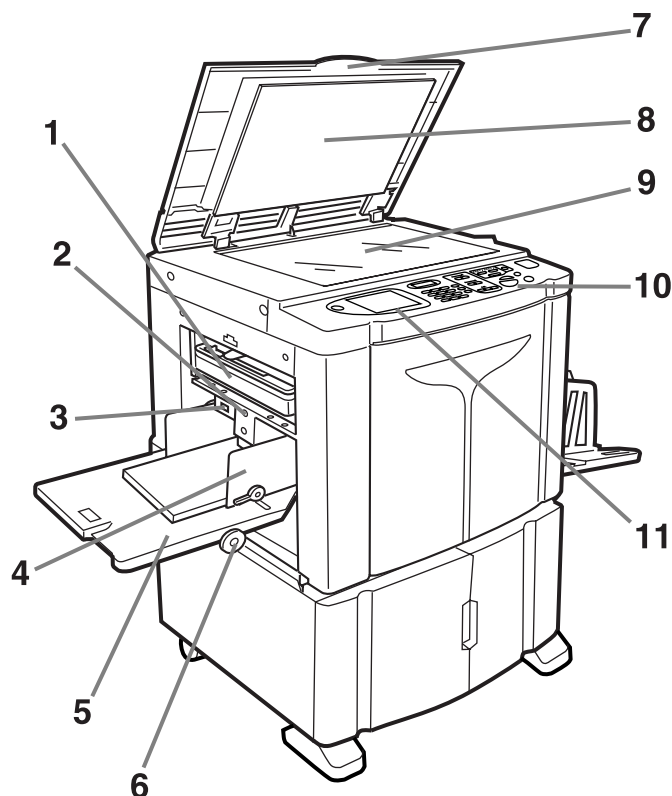

- 1) Master Disposal Box** (☞p.207)
Holds discarded masters.
- 2) Feed Tray Ascent/Descent Button** (☞p.34)
Lowers or raises the Paper Feed Tray when changing or adding paper.
- 3) Paper Feed Pressure Adjustment Lever** (☞p.33)
Adjusts the paper feed pressure according to paper in use.
- 4) Feed Tray Paper Guides** (☞p.32)
Holds and guides paper.
Slide to fit to the sides of paper.
- 5) Paper Feed Tray** (☞p.32)
Load print paper on this tray.
- 6) Horizontal Print Position Adjustment Dial** (☞p.91)
Move the print position to the left or right.
- 7) Platen Cover**
Opened and closed when placing the original.
- 8) Platen Cover Pad** (☞p.215)
- 9) Glass Platen** (☞p.38, ☞p.215)
Place the original face-down.
- 10) Control Panel** (☞p.22, ☞p.23)
Press the keys to perform various print operations.
- 11) Display** (☞p.24 ~p.29)
Displays various screens needed for print operations. Touch the buttons on the screen to execute various print operations.
- 12) Auto Document Feeder (Option)**
The Feeder can hold approximately 50 sheets of the original sheets (80 g/m² (21-lb bond)). Place the original face-down.
- 13) ADF Original Receiving Tray**
Scanned originals are ejected into this tray.
- 14) ADF Original Release Lever**
If an original is jammed, press to eject from the ADF unit.
- 15) ADF Original Guide**
Slides and adjusts to the width of the original to hold together.

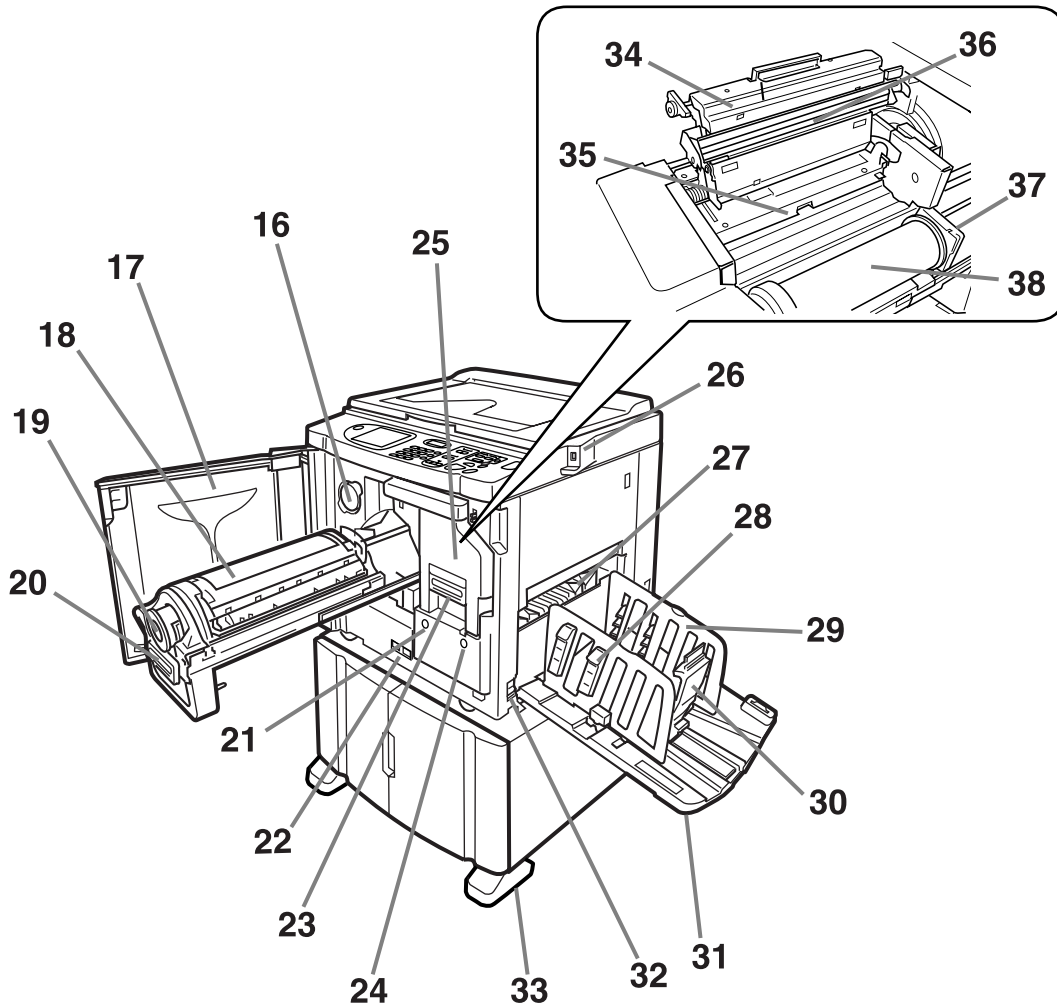
**16) Ink Cartridge Cap Holder (☞p.206)**

Secure the Ink Cartridge cap.

17) Front Cover**18) Print Drum (Cylinder) (☞p.209)****19) Ink Cartridge (☞p.205)****20) Print Drum (Cylinder) Handle (☞p.209)****21) Print Drum (Cylinder) Release Button (☞p.209)**

Unlocks the Print Drum (Cylinder) for removal.

22) Counter

Counts the number of copies (total print counter) and the number of made masters (master counter).

23) Master Making Unit Handle (☞p.202)**24) Master Making Unit Release Button (☞p.202)**

Unlocks the Master Making Unit for removal.

25) Master Making Unit (☞p.202)**26) USB Slot (☞p.42)**

Connect the USB Flash Drive.

27) Paper Jumping Wing (☞p.95)

Automatically adjusts to keep printed paper neatly stacked.

28) Paper Arranger (☞p.35)

Press to open for aligning printed paper.

29) Receiving Tray Paper Guides (☞p.35)

Aligns printed paper neatly.

Slide according to the width of print paper size.

30) Paper Stopper (☞p.35)

Slide to adjust to the length of print paper size.

31) Paper Receiving Tray (☞p.35)

Printed copies are output to this tray.

32) Power Switch (☞p.32)**33) Stabilizer****34) Master Making Unit Cover (☞p.202)**

Open and close to install Master Roll.

35) Master Guide Flap (☞p.203)**36) Thermal Print Head (☞p.215)****37) Master Roll Holder (☞p.203)****38) Master Roll (☞p.202)**

Control Panel

The Control Panel features permanent keys such as  and . It also has a large-size display that shows various messages and function buttons.

This section introduces hardware Key names and functions, as well as the display window and its functions.

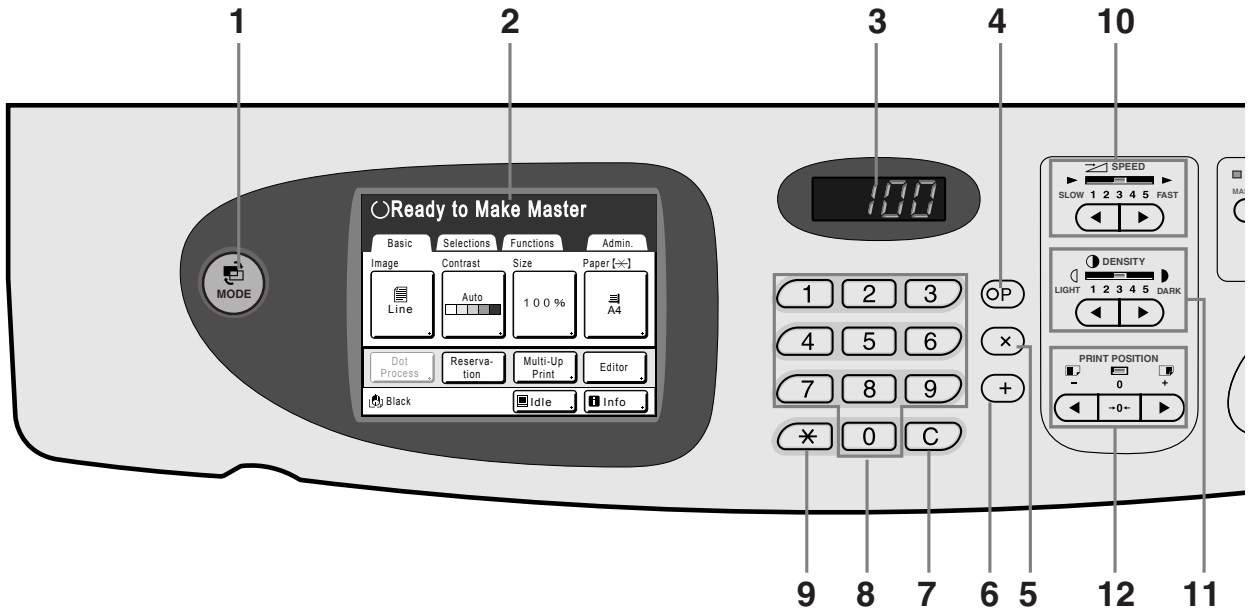

1) MODE Key (p.26)

Use to change modes.

2) Display (p.24 –p.29)

3) Print Quantity Display

Displays the number of copies, or numeric values entered for various settings.

4) P Key (p.127)

Use to retrieve stored programs. The indicator on the key lights when set.

5) × Key (p.127)

Use to move between fields in setup screens, or set up programed printing.

6) + Key (p.127)

Use to move between fields in setup screens, or set up programed printing.

7) C Key

Cancels entered numerical values, or reset the counter to 0.

8) Print Quantity Keys (0 to 9 Keys)

Use to enter the number of copies, or the numerical values for various settings.

9) * Key (p.127, p.136)

Use to move between fields in setup screens, or retrieve stored memory.

10) Print Speed Adjustment Keys/Indicator (p.88)

Selects the print speed from five levels. The indicator above the keys shows the current speed level.

11) Print Density Adjustment Keys/Indicator (p.89)

Selects the print density from five levels. The indicator above the keys shows the current density level.

12) Vertical Print Position Adjustment Keys/Indicator(p.90)

Adjusts the print position in the vertical direction (within ±15 mm (±19/32")) after making a master.

The indicator above the keys shows the offset amount from the center.

To clear the offset amount, press .

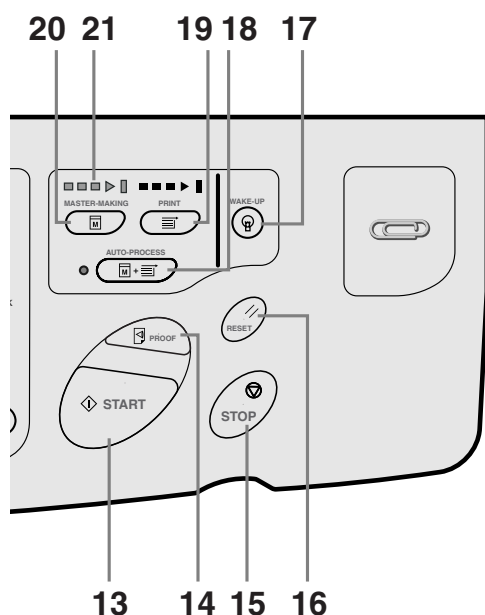

13) Start Key

Starts master-making or printing process or executes specified operations.
The key is lighted only when the key is active.

14) Proof Key (☞ p.92)

Use to check print result after adjusting the print position, for example.
This allows you to print proof copies without affecting the value on the Print Quantity Display.

15) Stop Key

Stops current operation in progress. During the master-making procedure, the machine will not stop until the master-making process is completed.

16) Reset Key

Returns all settings to the initial settings.

17) WAKE-UP Key / Log out Key (☞ p.37, ☞ p.43, ☞ p.46)

Wakes up the printer in Energy Saving mode.
Use this key also to log out from the machine.

18) Auto-Process Key (☞ p.61)

Performs non-stop operation from master-making through printing. When activated, the indicator besides the key lights.

19) Print Key

Makes the printer be ready for printing.

20) Master-Making Key

Makes the printer be ready for making masters.

21) Progress Arrows

Indicates master-making and printing progress status.

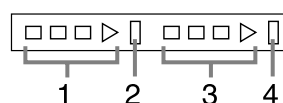

- 1) Master-Making Indicator
- 2) Master-Making Stop Bar
- 3) Print Indicator
- 4) Printing Stop Bar

Ready to make a master (Auto ON): when 1 is blinking
Ready to make a master: when 1, 2 are blinking
Ready to print: when 3, 4 are blinking
The indicator increases one bar at a time from the left, indicating the progress of the current master-making or printing job.

- If a master-making or printing job is halted, the progress bar stays lit at that position. (Ready for resume)

Display

The Screens and their Various Stages

When the power is turned on, after a brief display of the start-up screen, the initial screen appears.

Power ON



Start-Up Screen (Ex.)

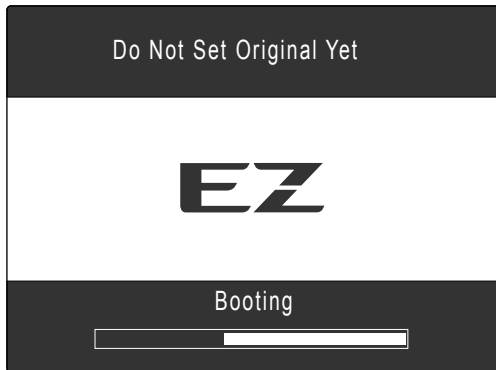

Note:

- Start-Up Screen settings
Select **[Start-Up Screen]** on the Admin. screen.



Initial Screen (Ex.)

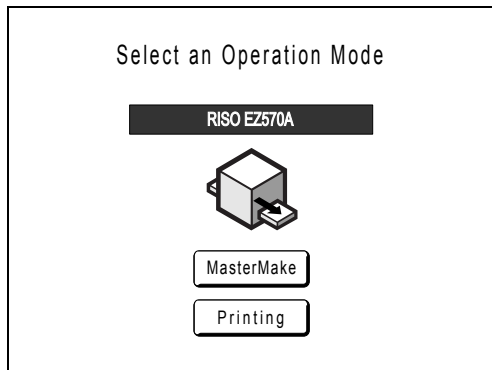

Note:

- Initial Screen settings
You can select **[Mode Screen]**, **[RISO Print]** or **[Scanning]** as the initial screen to best suit your needs. Select **[Display Priority]** on the Admin. screen. Refer to the following pages for more information about the different types of initial screen.

When [Mode Screen] is selected for the Initial Screen

Select **[Mode Screen]** if you scan from a wide variety of originals.
The Mode Screen appears at start-up.

Mode Screen

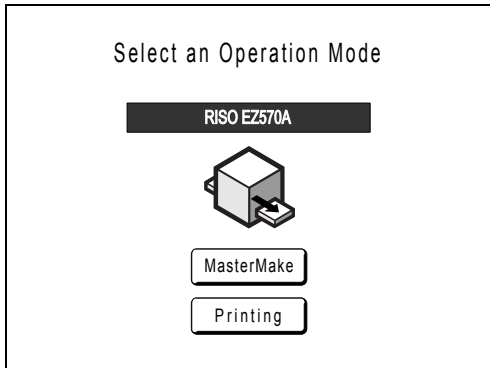

When the optional Document Storage Card DM-128CF or USB Flash Drive is attached

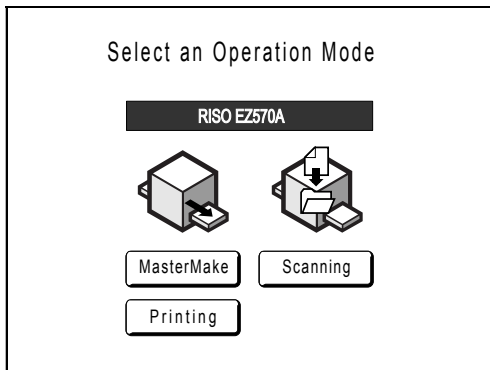

- Touch **[MasterMake]** to display the Master Making Basic Screen.

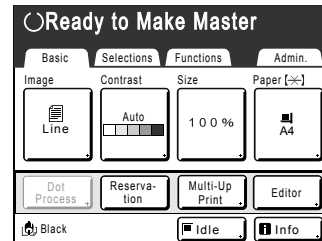

- Touch **[Printing]** to display the Print Basic Screen.

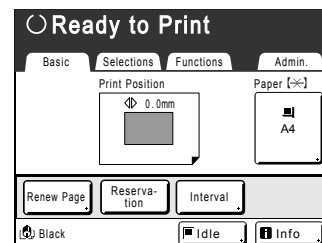

- Touch **[Scanning]** to display the Scan Basic Screen.

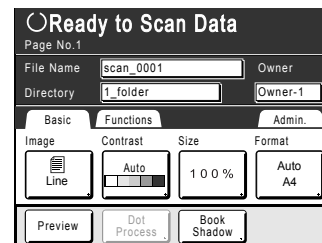

Note:

- Refer to "Storing Original Data and Use Method" (p.182) for information about storage memory and scan mode.

When [RISO Print] is selected for the Initial Screen

If you are printing directly from the machine, we recommend that you select **[RISO Print]**.
The Print Basic Screen displays at start-up.

Print Basic Screen

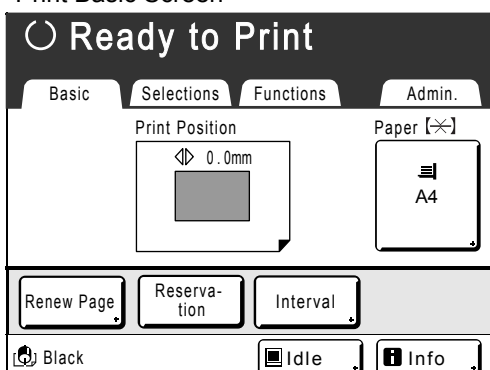

When [Scanning] is selected for the Initial Screen

If you frequently scan and save original documents, we recommend that you select **[Scanning]**. The Scan Basic Screen displays at start-up.

Scan Basic Screen

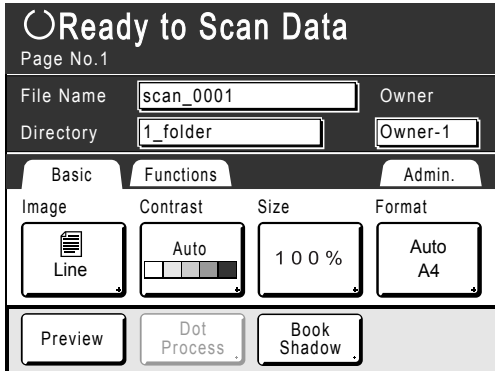

Note:

- Refer to “Storing Original Data and Use Method” (p.182) for information about storage memory and scan mode.
- This setting is available when the optional Document Storage Card DM-128CF or USB Flash Drive is attached.

Note:

- key

key can be set to function as “Mode Selection” or “Loop”. Select “Mode Key Pattern” on the Admin. screen. (p.161)

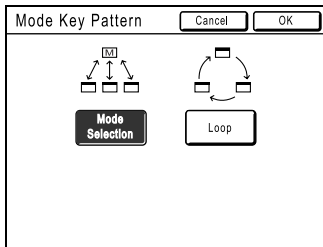

[Mode Selection]

[Loop]

Pressing the key will open the Mode Screen no matter which screen you are currently on.

The screen changes as shown below when the key is pressed.

- Normally: “Master Making Basic Screen” ↔ “Print Basic Screen”
- When the optional Document Storage Card DM-128CF or USB Flash Drive is attached: “Scan Basic Screen” ↔ “Master Making/Print Basic Screen”

Tip:

About the Recognition Screen

This machine is equipped with a User Management function. (p.104, p.166 “Admin.”). If “User Management” is set, the Recognition Screen is displayed. If the one of these screens shown on the right side is displayed, input the PIN code or connect the registered USB Flash Drive. Consult your administrator for the PIN code and the registered USB Flash Drive.

PIN code Input Screen

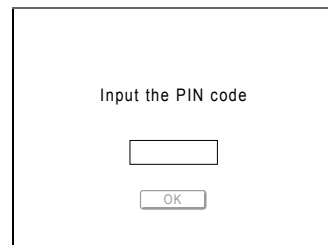

Registered USB Flash Drive Screen

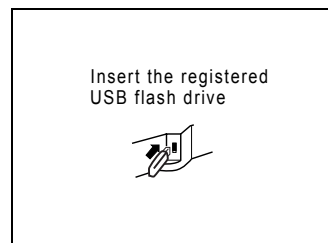

Other screens

◆ Selections Screen

Quickly change settings for a function or open its screen.

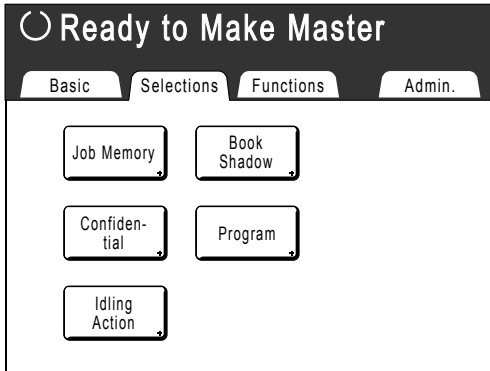

◆ Functions Screen

Access to a variety of functions.



◆ Admin. Screen

Changes the default values of various functions.

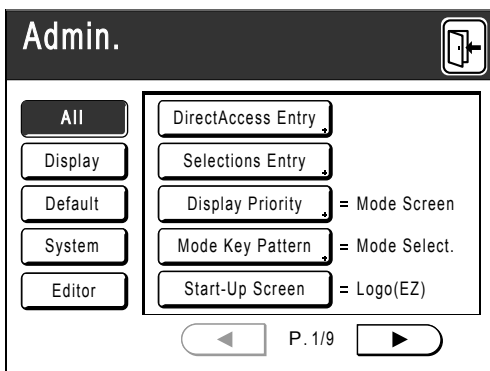
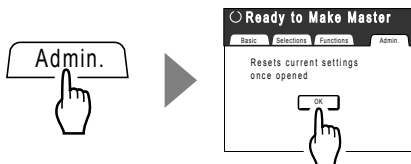

Basic Screen Layout

The name and function of each area of the basic screens are explained below. The display of the basic screen differs depending on whether you are printing from a paper document or printing from a computer.

Printing from a Paper Document



1) Tab Area

Touch a tab to display its screen.

2) Functions Area

The main functions for master-making/printing steps. Each button shows the current setting. Touch the button to make changes.

3) Direct Access Area

Up to four buttons can be registered in advance. Use this area to register the most frequently-used functions. You can register them on the Admin. screen.

☞ p.171

4) Status Area

Displays the current status of the machine.

: Color (Colour) of the currently installed Print Drum (Cylinder).

: Status of data sent from a computer. Touch to display the list of data being received.
☞ p.45

- **[Idle]**: Ready to receive data
- **[Data-Map]**: Processing data for printing.
- **[Pause]**: Ready for output.
- **[Error]**: Error in data transmission.
- **[Blocked]**: Cannot receive data

: Touch to display information (consumables information, Print Drum (Cylinder) information, date/time).
☞ p.201

Printing from a Computer Data

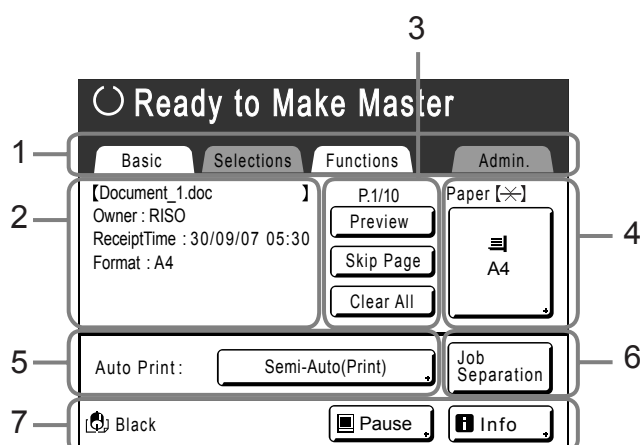

1) Tab Area ("Selections" and "Admin." tabs are disabled)

Touch a tab to display its screen.

2) Job* Properties Area

Properties of the current print job is displayed.

*Refers to the computer data ready for print output.

3) Job Operation Area

- **[Renew Page]:** Create another master when current one is damaged or compromised, without having to download data from the computer.
- **[Preview]:** Displays the master making image of the page currently awaiting creation. (Available only in the Master Making Basic Screen.)
- **[Skip Page]:** Stops processing the current page and moves on to process the next page.
- **[Clear All]:** Stops the current process altogether.

4) Paper Button

☞ p.60

5) Auto Print

A printing operation can be set to stop at certain points. (overrides driver settings)

☞ p.51

6) Optional Device Area

Displays when an optional device is attached. Touch to activate.

7) Status Area

Displays the current status of the machine.

This area shows the same information as that on the "Printing from a paper Document" screen.

Note:

- Depending upon the usage environment, some of the "Admin." features may not be available ("Admin." tab may not be displayed). Consult your dealer (or authorized service representative) for details.
- For information on other screens and their functions or settings, refer to corresponding pages.

Buttons on Touch Screen

Select buttons by lightly touching with a finger.

Touch again to cancel the selection. Avoid pressing with excessive force.

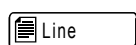

Not Selected.



Selected.

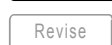

Buttons in gray cannot be selected.



Press a button with a + on the right side to expand options or display Setup screens.

Frequently Used Buttons

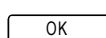

Activates/Executes a setting.

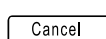

Cancels a setting.

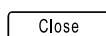

Closes a current window.



Switch pages.



Increases/decreases selected values (numbers, location, etc.).
Scrolls through screens.

Basic Process

Printing from a Paper Document

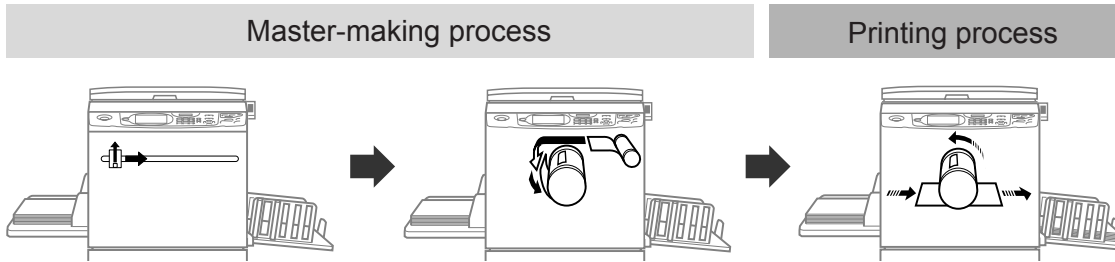

A placed original is scanned by the scanner, and a generated master is rolled around the Print Drum (Cylinder). After a while, proof copy is performed. After checking the print result, enter the number of copies to be printed and start printing.

Printing from a Computer Data

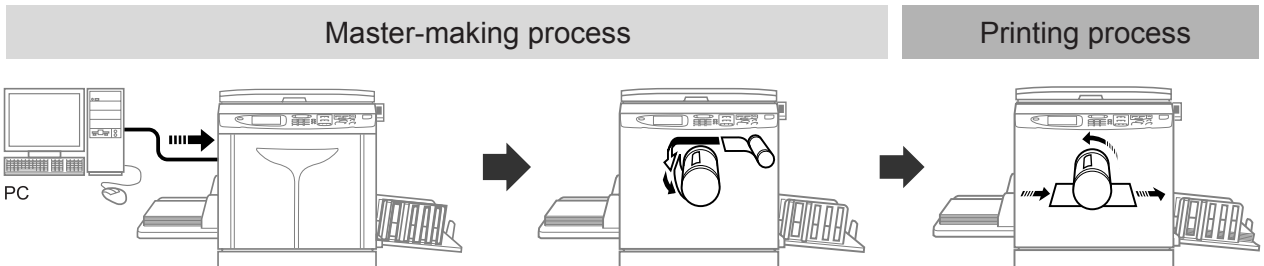

Data sent from a computer is transformed into images, and a generated master is rolled around the Print Drum (Cylinder). You can send instructions for printing from the computer (through the printer driver).

Printing from a USB Flash Drive

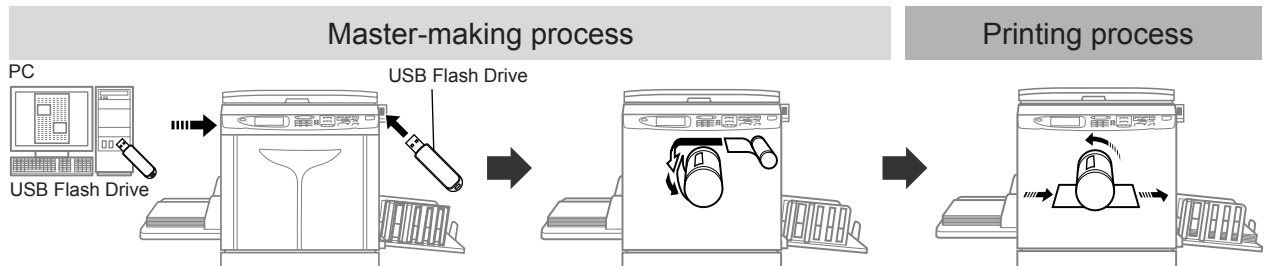

Output the data created on a computer to the USB Flash Drive and connect the USB Flash Drive to the USB slot. The generated master is rolled around the Print Drum (Cylinder).

Note:

- The USB flash-via-printer driver is required.

Basic Operations

Preparing to Print

First, set up the Paper Feed Tray and Paper Receiving Tray of the machine.

Important!:

- Do not use unsuitable paper, or mix paper of different sizes. Doing so can cause paper jams and damage the machine.
☞ p.15

Setting up the Paper Feed Tray and Loading Paper

1 Turn the power ON.

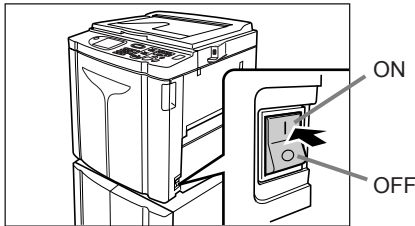

2 Open the Paper Feed Tray.

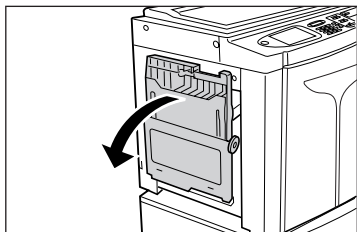

Pull the Paper Feed Tray to open until it comes to a rest.

3 Load paper.

- 1) Place paper in the printing orientation.
- 2) Slide the Feed Tray Paper Guides to fit to the sides of the paper. Then turn the right and left Feed Tray Paper Guide Levers to lock the guides.

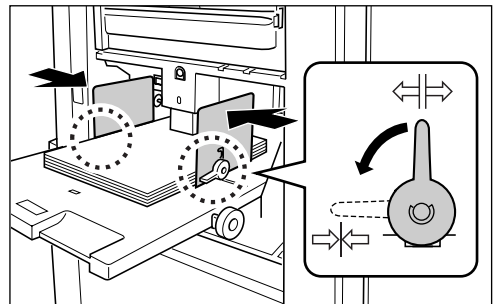

⇄ : Unlock

⇄ : Lock

Important!:

- Make sure that the Feed Tray Paper Guides fit tight up against the paper. Failure to do so can produce undesired results.

Note:

- Custom-sized paper must be registered on the Admin. screen before use.
☞ p.174
Failure to do so may create an incomplete master.

4 Select the paper feed pressure.

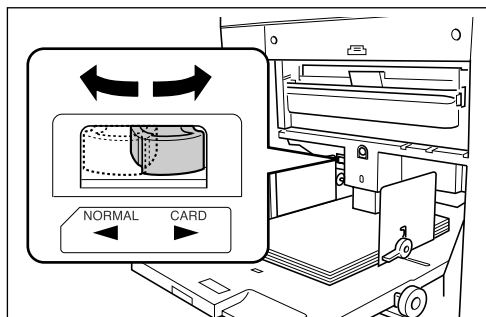

Position the Paper Feed Pressure Adjustment Lever according to the finish of the paper.

NORMAL (☒): For standard or thin paper

CARD (☐): For thick or smooth-surface paper

Note:

- The setting condition of the paper feed pressure is displayed at the top of the **[Paper]** button on the Basic Screen.

5 Check the Basic Screen.

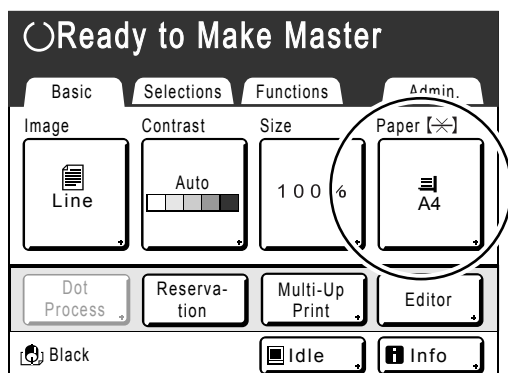

Note:

- Paper size is automatically detected. If the size display shows **[Custom]** even if a standard-sized paper is loaded, the Feed Tray Paper Guides are not properly set against the paper. Make sure that the paper fits tightly against the Feed Tray Paper Guides.

☞ p.32

Adding or Replacing Paper

When you add paper or replace with paper of a different size at the time of printing, press the Feed Tray Ascent/Descent Button to lower the Paper Feed Tray.

- The Paper Feed Tray is lowered while you press and hold the button, and when you release the button, the tray stops at that position.
- When the tray runs out of paper or you remove all paper, the tray is automatically lowered to the bottom.

Important!:

- When changing to a different paper size, remember to readjust the Receiving Tray Paper Guides and Paper Stopper. (p.35)
- When changing to a different quality paper, remember to adjust the Paper Feed Pressure Adjustment Lever.

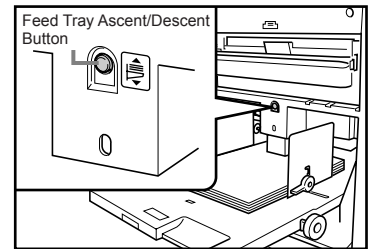

Closing the Paper Feed Tray

Before closing the Paper Feed Tray, remove the paper and widen the Feed Tray Paper Guides to the limits. Then close the Paper Feed Tray.

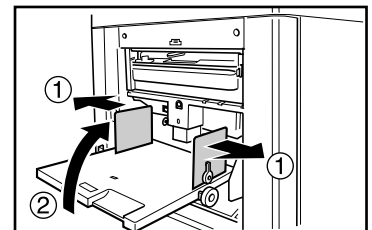

Setting up the Paper Receiving Tray

1 Open the Paper Receiving Tray.

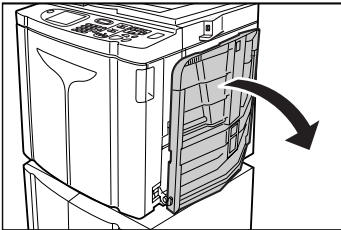

Pull the Paper Receiving Tray down until it comes to a rest.

2 Position the Receiving Tray Paper Guides.

- 1) Raise the Receiving Tray Paper Guides.
- 2) Hold their lower part and slide them to fit the paper width.

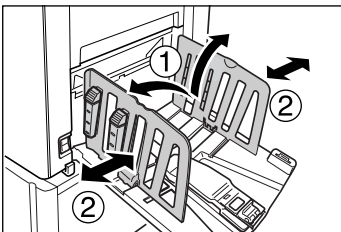

Important!:

- For thick paper such as drawing paper, position the Receiving Tray Paper Guides a little wider than the actual paper width.

3 Set the Paper Stopper.

- 1) Raise the Paper Stopper.
- 2) Slide to fit the length of the paper.

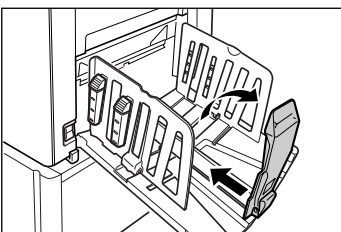

4 Adjust the Paper Arrangers.

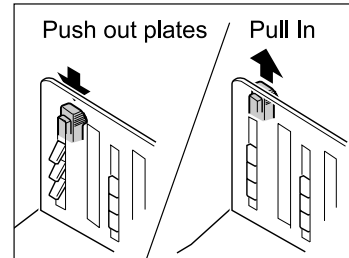

Alignment of paper is affected by sizes and strength of paper. Adjust the Paper Arrangers so that printed paper is aligned. Press the Paper Arranger to push the plates out, pull up to pull them in.

◆ For plain paper

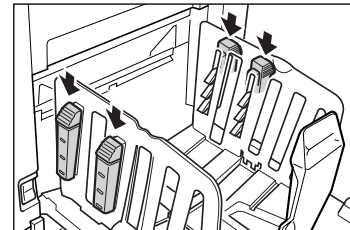

Press to open all of the four Paper Arrangers.

◆ For plain paper with images lopsided on page

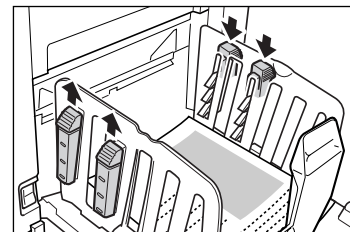

Press to open the two Paper Arrangers on the more heavily printed side.

◆ For thick paper

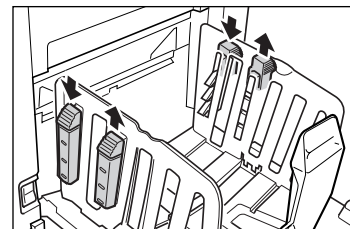

Press to open the two Paper Arrangers (right and left) closer to the machine.

Closing the Paper Receiving Tray

Remove all printed copies and follow the steps below to close the Paper Receiving Tray.

- 1) Slide the Paper Stopper to the edge of the Paper Receiving Tray.

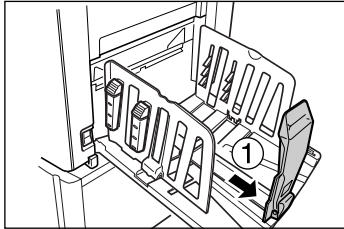

- 2) Fold in.

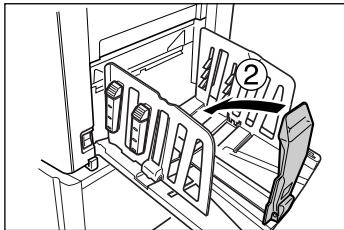

- 3) Pull up the Paper Arrangers, slide the Receiving Tray Paper Guides to the left and right as far as they will go.

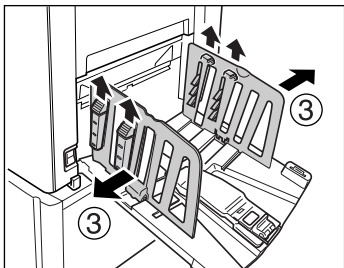

- 4) Fold in.

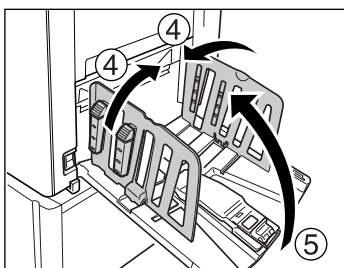

- 5) Close the Paper Receiving Tray.

Printing from a Paper Document or Book

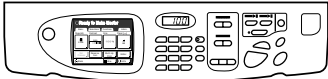

The steps for scanning an original for printing is explained below.

1 Make sure the machine is ON.



Check the Control Panel.

Note:

- When the power is OFF, both the Display and the  key are off. Turn the power ON.
☞ p.32
- If the  key is lit, the machine is in Energy Saving mode. Press the  key to cancel Energy Saving mode.

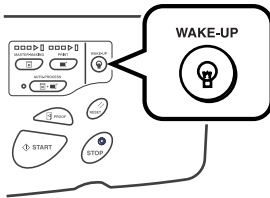

2 Check for printing paper.

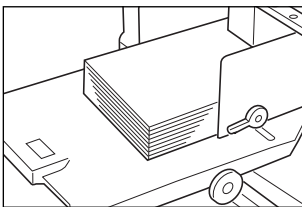

Make sure paper is loaded.

To load or to change the paper, see the following page:

☞ p.32

After replacing with paper of a different size, adjust the position of the Receiving Tray Paper Guides and Paper Stopper.

☞ p.35

3 Check the Display.

The initial screen differs depending on the setting of “Display Priority” of “Admin.”

- If current screen is in Mode Selection, touch **[MasterMake]** to switch to the Master Making Basic Screen.

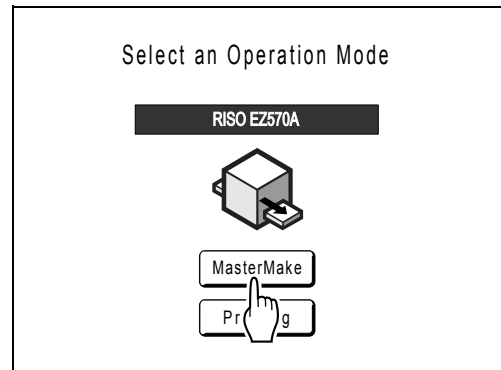

The following screen appears.

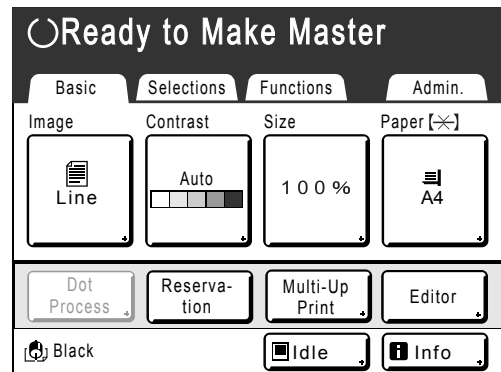

- Make sure either the Master Making Basic Screen or Print Basic Screen is displayed, and go to step 4.

Note:

- When you see **[Data-Map]** in the Status Area, the machine is busy receiving electronic data from the computer. Please wait a moment.
- When the following screens are displayed, follow the message on the screen. For details, see ☞ p.42.

(PIN code Input Screen)

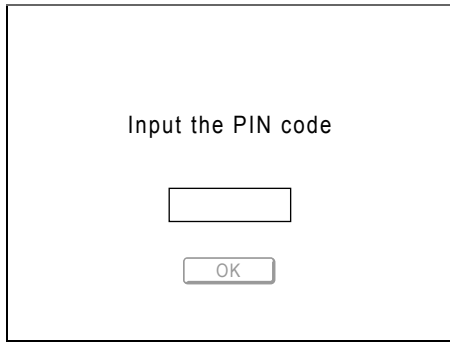

(Registered USB Flash Drive Screen)

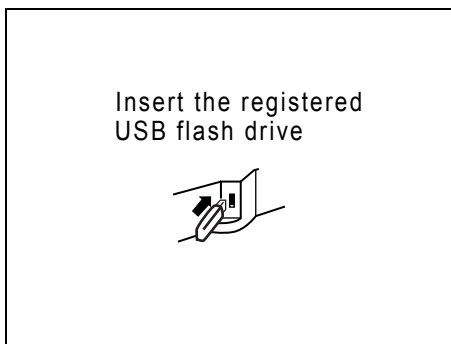

The initial screen will be displayed after the user has been identified.

4 Place the original.

Place the original on the Glass Platen or in the ADF unit (Option).

◆ When placing on the Glass Platen

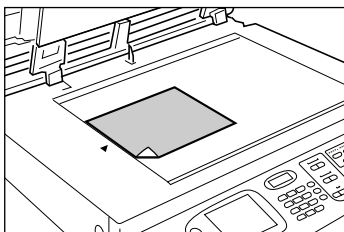

Place the original face down on the Glass Platen. Align center on the top edge, and close the Platen Cover. Magazines, books, scrap books, etc. should be placed on the Glass Platen.

Note:

- If the Gauge Cover is installed, place the original underneath.

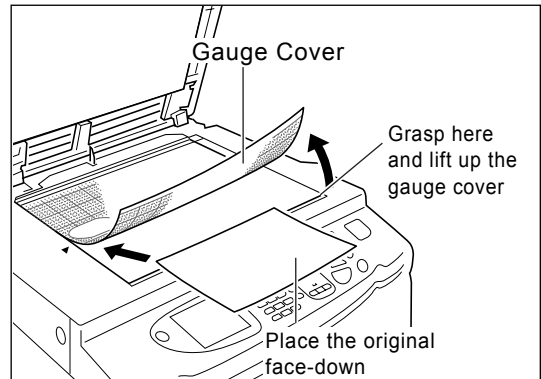

◆ When placing in the ADF unit (Option)

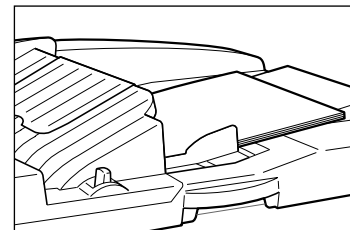

Use the ADF unit if you are printing multiple originals in succession. Place originals face-down and then adjust the ADF Original Guides to the width of the originals. Insert the originals as far into the ADF unit as possible.

Note:

- For set originals, master-making and printing are done in sequence from the top (from the last page).

Important!:

- The ADF unit can accommodate originals of 100 mm × 148 mm (3¹⁵/₁₆" × 5²⁷/₃₂") and above. Smaller originals should be placed on the Glass Platen.
- Do not place multiple originals of differing sizes or otherwise unsuitable originals into the ADF unit. Doing so can cause paper jams and damage the machine.

☞ p.17

- Once the originals are placed into the ADF unit, “Auto Process” setting is turned ON. Press the  key to turn it OFF.

Default “Auto Process” setting for the ADF unit can be changed on the Admin. screen.

[p.61](#)

[p.163](#)

Note:

- Up to 50 sheets of 80 g/m² (21-lb bond) paper can be placed in the ADF unit.
- To print a proof copy after each master-making process, select **[ADF Semi-Auto]**.
[p.150](#)

5 Configure print functions.

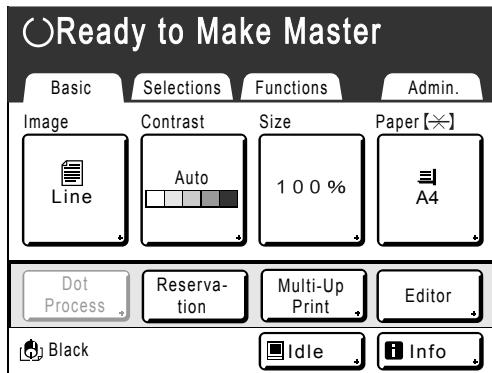

Make sure the Master Making Basic Screen is displayed and make various settings if needed.

If the Master Making Basic Screen is not displayed, press the  key.

In the Master Making Basic Screen, select functions as needed.

Note:

The following selections are available:

- Image Processing mode ([p.52](#))
- Scanning Contrast ([p.54](#))
- Size ([p.55](#))
- Paper ([p.60](#))
- Auto Process ([p.61](#))
- Dot Process ([p.62](#))
- Ink Saving ([p.64](#))
- 2 Up/Multi-Up Print ([p.65](#))
- Book Shadow ([p.77](#))
- Top Margin ([p.79](#))
- Side Margin ([p.81](#))
- Preview ([p.83](#))
- Max. Scan ([p.86](#))
- Program ([p.125](#))
- Job Memory ([p.136](#))
- Idling Action ([p.146](#))
- Renew Page ([p.147](#))
- ADF Semi-Auto ([p.150](#))
This setting is available when the ADF unit (Option) is installed.
- Job Separation
This setting is available when the Job Separator (option) is installed.
- Sorter
This setting is available when the Sorter TM2500 (option) is installed.

6 Check the Paper Receiving Tray.

Adjust the position of the Receiving Tray Paper Guides and Paper Stopper to match the paper size used.

[p.35](#)

7 Press the key.

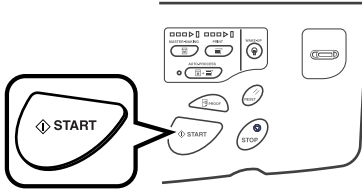

Starts scanning of the original. A master is made once the scan is completed, and a proof copy will be printed.

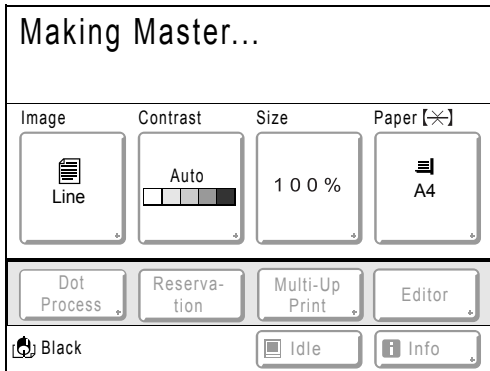

Tip: Auto Idling

When “Auto Idling” is set to ON, idling operations may occur when master-making process is initiated.

Factory default is set to idle automatically at the beginning of the master-making when the machine is inactive for over 12 hours.

To toggle “Auto Idling” ON/OFF, or to modify number of hours before activating next idling, go to the Admin. screen.

[p.166](#)

Idling can also be manually initiated when making a master.

[p.146](#)

Note:

- When “Auto Process” is selected, the process will be different.
[p.61](#)

8 Check the proof copy result.

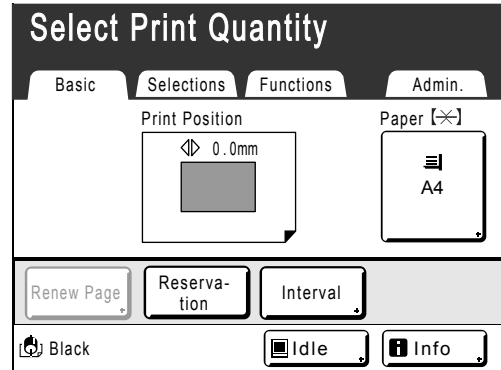

When a proof copy is printed, the Print Basic Screen will be displayed automatically.

Check the proof copy; e.g., print position and density.

If necessary, change print position and density.

- Print Position ([p.90](#))
- Print Density ([p.89](#))
- Interval Printing ([p.93](#))
- Jump Wing Control ([p.95](#))

After adjustment, press the  key to print a proof copy.

Important!:

- When the machine has not been used for a long period of time, the print quality may suffer due to dry ink on the Print Drum (Cylinder). Press the  key to print proof copies several times.

Note:

- You can also adjust the print position (up and down only), the density, and the speed while print process is in progress.

9 Enter the number of copies using the Print Quantity Keys.

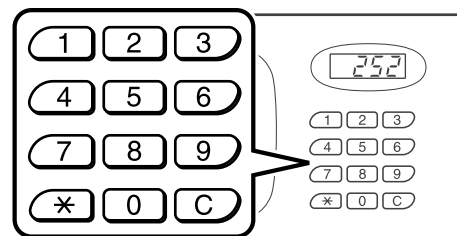

The entered number is displayed on the Print Quantity Display.

Note:

- To change the number, press the **C** key, then re-enter the correct number.

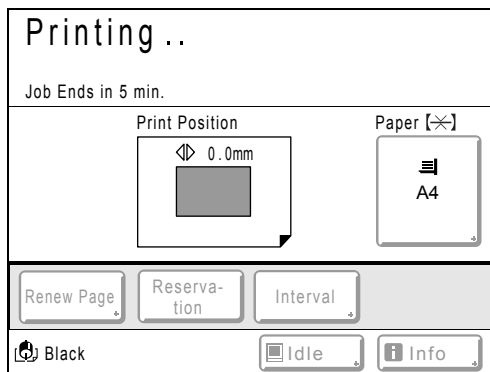
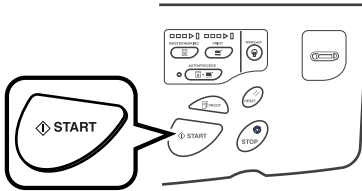
10 Press the  key.

The specified number of copies will be printed.

Note:

- Press the  key to interrupt printing operation currently underway.
- When printing from a computer, if the machine is inactive for a certain period of time, it determines that the current job is completed, even if the actual printing is still under way. If another person accidentally initiates another job from the computer, this will cause a new master to be made, discarding the current one. To prevent this from occurring, you may set a "Reserve Period". We recommend that you activate the "Reservation" setting when printing leaflets, etc. to prevent interruption.

 p.145

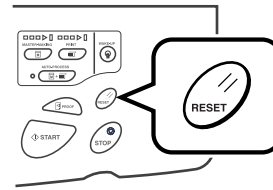
11 Press the  key when print job is complete.

The setting returns to its default value.

Note:

- After printing is completed, the master remains on the Print Drum (Cylinder). To protect confidential documents from unauthorized duplication, use the Confidential feature to discard the master after printing.

 p.124

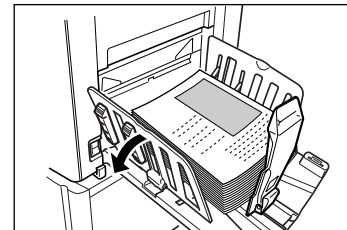
12 Remove the printed paper.

Open the Receiving Tray Paper Guides and remove the paper.

Note:

- Easily restore current settings by saving them into memory. Saved settings can be retrieved even when the  key is pressed, or after turning the power off.

 p.136

Tip:
Operations on the Recognition Screen

When “User Management” is set by the administrator, the users will be asked to identify themselves (“User identification access”: if he/she is registered or not) during operations.

The user identification procedures will differ according to the Recognition and Identification System decided by the administrator. [p.104](#)

Note:

- A PIN code and USB Flash Drive are used in the Recognition and Identification System. Contact your administrator for the PIN code and the USB Flash Drive you have to use.

◆ **When the PIN code Input Screen is displayed**

Enter the PIN code using the Print Quantity Keys and touch [OK].

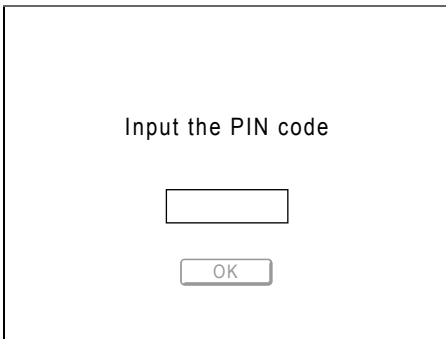

The initial screen will be displayed after the user has been identified.

Note:

- If an incorrect PIN code is entered, an error message will be displayed. Re-enter the correct PIN code.

◆ **When registered USB Flash Drive Screen is displayed**

Connect the registered USB Flash Drive to the USB slot.

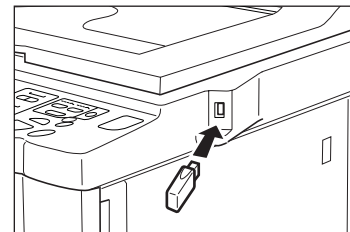
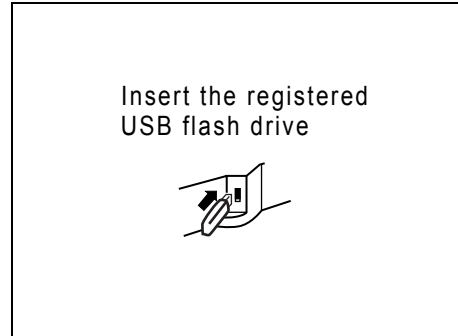

The initial screen will be displayed after the user has been identified.

Note:

If an unregistered or unusable USB Flash Drive is connected into the machine, an error message will be displayed. Connect the registered USB Flash Drive.

Important!:

After printing is completed, press the  key to log out before leaving the machine. If you do not log out, the logged-in state will remain until “Auto Clear” is activated. During this time, anyone can use the machine (as you) without logging in.

For “Auto Clear”, see [p.165](#).

Printing from a Computer Data

[Direct Print] [USB Job List]

This machine can directly print the original created on the computer by connecting the computer and machine by cable. The data will be digitally processed into a master, thus achieving higher quality prints than the master-making of scanned originals.

Furthermore, a USB slot for connecting a USB Flash Drive is supplied with this machine so that you can print by connecting a USB Flash Drive that stores the data of originals to the machine even if the computer and machine are not connected by cable.

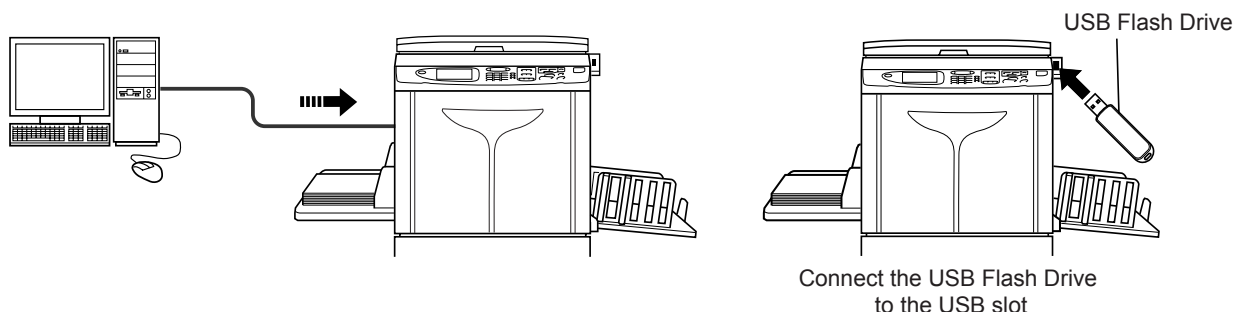

Important!:

- First, install a proper printer driver on your computer. See the “RISO Printer Driver User’s Guide” for installation details.
- A printer driver and a USB flash-via-printer driver are provided. For details, see the “RISO Printer Driver User’s Guide”.

Note:

- This manual provides only a summary of functions available when printing from a computer. See the “Riso Printer Driver User’s Guide” for further details on sending data and other settings.

Printing Computer Data [Direct Print]

The computer and printer must be connected by cable.

Note:

- When “User Management” is set by the administrator, the users will be asked to identify themselves during operations. [p.42](#)

1 Make sure the machine is ON.

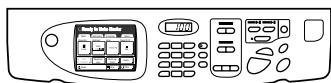

Check the Control Panel.

Note:

- When the power is OFF, both the Display and the  key are off. Turn the power ON. [p.32](#)
- The machine automatically wakes up from Energy Saving mode when data is sent from a computer, and it starts processing the data.

2 Check for printing paper.

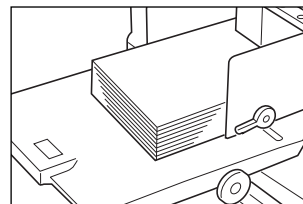

Make sure paper is loaded.

To load or to change the paper, see the following page: [p.32](#)

After replacing with paper of a different size, adjust the position of the Receiving Tray Paper Guides and Paper Stopper.

[p.35](#)

3 Set printing options from your computer screen.

Use the printer driver.

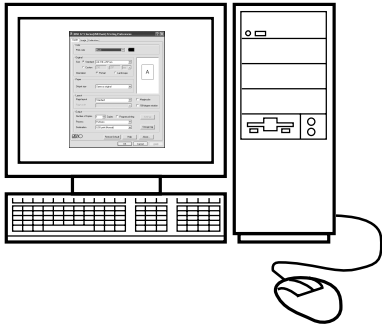

Important!:

- Make sure to remove the checkmark from the “Collate” option in the Print dialog box.
- When the machine has not been used for a long period of time, the print quality may suffer due to dry ink. Before printing, either perform an Idling Action (p.146) (especially when using Full Auto mode) or press the key to print proof copies several times.

4 Click [OK] in the print dialog box.

Data is sent from the computer. When the machine receives data, a print job automatically starts in accordance with the printer driver settings. Skip to step 6 if you are printing in “Full Auto”.

5 Perform printing from the control panel.

The displayed screen and operation procedure differ depending on the “Process” (Guide tab) setting of the printer driver.

◆ **Printing with Semi-Auto (Print)**

The Master Making Basic Screen in step 2) is halted depending on the use of the machine or Admin. settings. In this case, press the key.

1) Touch .

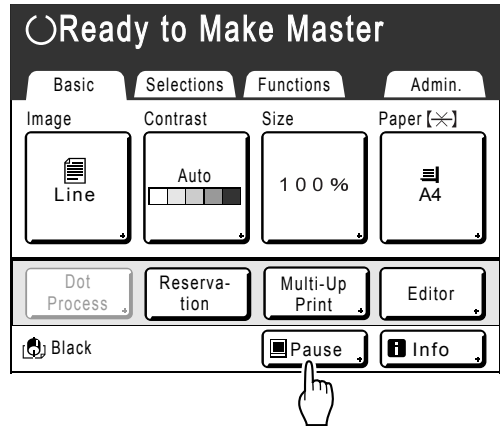

The Job List screen is displayed.

2) Touch [Output].
If you want to operate the ID print, touch [ID Print Job].

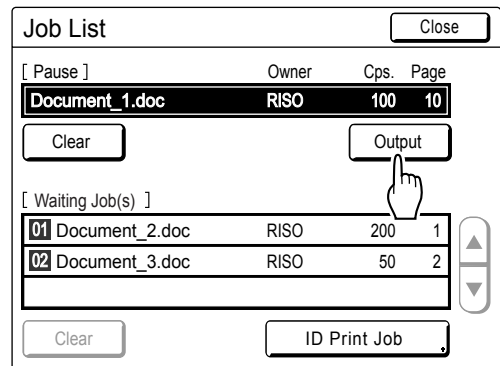

The following screen appears.

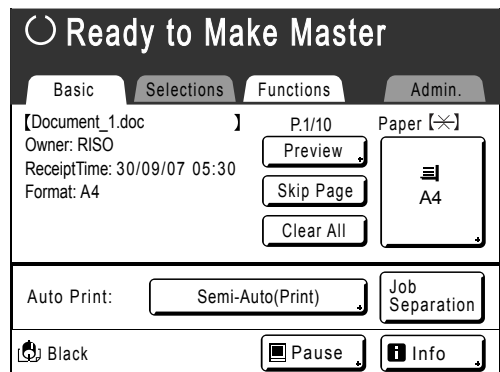

3) Press the key.
After making a master, start printing.

◆ Printing with Semi-Auto (Master)



A master is made after receiving the data. The machine stops after printing a proof copy.

- 1) Check the proof copy and adjust the settings as needed.
- 2) Press the  key.
Printing starts.

◆ Printing with Manual

- 1) Follow steps 1 to 3 in “Printing with Semi-Auto (Print)”.
Stop after making a master and printing a proof copy.
- 2) Check the proof copy and adjust the settings as needed.
- 3) Press the  key.
Printing starts.

Note:

- If “Management Level” is set to “High/Full Management” in “User Management”, be sure to touch the **[Pause]** button and touch the **[Output]** button in the Job List screen after you have been identified.
- If the data contains multiple pages, repeat the same steps for each page.
- Entering the number of copies from the Print Quantity Keys will override the number specified in the Print dialog box.
- To manually stop a job during master-making or printing operation, press the  key. In master-making process, the machine will stop after the master is made. In the printing process, the machine will stop printing.
Press the  key to resume the job.
- You can also adjust Print Position (up and down only), the density, and the speed while Print process is in progress.

6 Remove the printed paper.

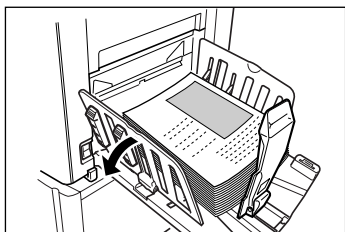

Open the Receiving Tray Paper Guides and remove the paper.

Note:

- After printing is completed, the master remains on the Print Drum (Cylinder). To protect confidential documents from unauthorized duplication, use the Confidential feature to discard the master after printing.

Tip: Job List Screen

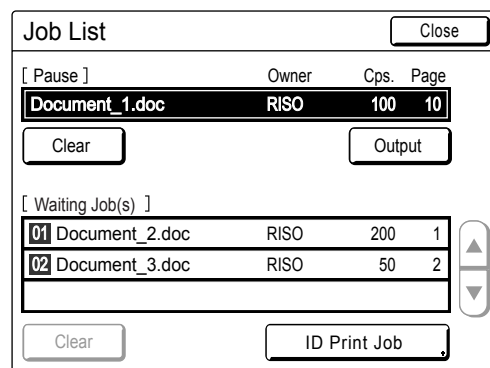

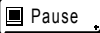
Once the data is received, touch  on the Basic Screen to review current Job List. From the Job List screen, you can initiate output for jobs pausing for output, or cancel jobs that are “Paused/Data-Mapping/Waiting”.

Tip: ID Print

The data sent from the printer driver as the “ID Print” is retrieved from the ID Print Job Screen and printed. For details on how to display the ID Print Job Screen, see step 5 of .

If the Recognition Screen will be displayed, follow the message on the screen.

The timing of the Recognition Screen differs depending on the “User Management” setting set by the administrator.

Note:

- To set the “ID Print” in the printer driver, a user registration number (ID) is required (one or two digits).
Contact your administrator for the PIN code or registered USB Flash Drive, and the user registration number (ID).

Printing USB Data [USB Job List]

Even if the computer and machine are not connected by cable, you can print original data via a USB Flash Drive. It is useful when the computer and printer are placed in different places.

Note:

- When "User Management" is set by the administrator, the users will be asked to identify themselves during operations. For details, see [p.42](#).

1 Connect the USB Flash Drive to the computer.

Note:

- If the Recognition and Identification System ("Recognized by") is set to "USB Flash Drive" in the "User Management", it is also convenient for you to use the registered USB Flash Drive for outputting data.

2 Set printing options from your computer screen.

Use the USB flash-via-printer driver.

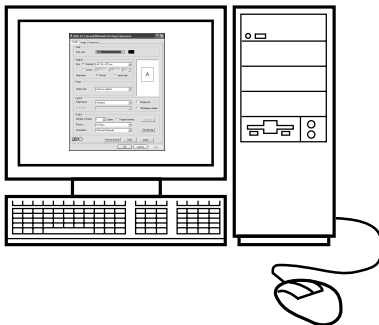

Note:

- Make sure to remove the checkmark from the "Collate" option in the Print dialog box.

3 Click [OK] in the print dialog box.

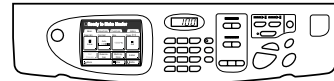

The data created on the computer is stored in the USB Flash Drive.

4 Make sure the machine is ON.



Check the Control Panel.

Note:

- When the power is OFF, both the Display and the  key are off. Turn the power ON. [p.32](#)
- If the  key is lit, the machine is in the Energy Saving mode. Press the  key to cancel the Energy Saving mode.

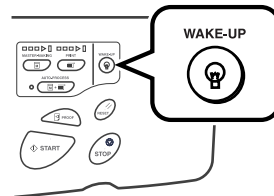

5 Check for printing paper.

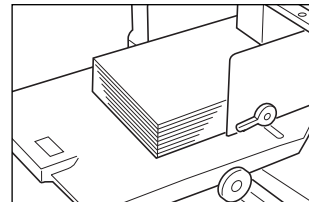

Make sure paper is loaded.

To load or to change paper, see following page.

[p.32](#)

After replacing with paper of a different size, adjust the position of the Receiving Tray Paper Guides and Paper Stopper.

[p.35](#)

- 6** Connect the USB Flash Drive that contains the original data to print to the USB slot.

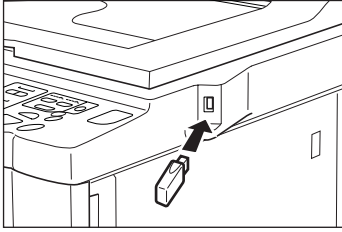

If you use an unregistered USB Flash Drive for outputting data, skip to step 9.

Important!:

- Do not remove the USB Flash Drive while accessing. Doing so can cause data loss or damage to the USB Flash Drive.

Note:

- If the “USB print (Auto Process)” has been set as the output method (Guide tab), connecting the USB Flash Drive starts master-making/printing process as per the “Process” setting. For detailed settings, refer to the “RISO Printer Driver User’s Guide”.

- 7** Touch [Functions] on the Master Making Basic Screen.

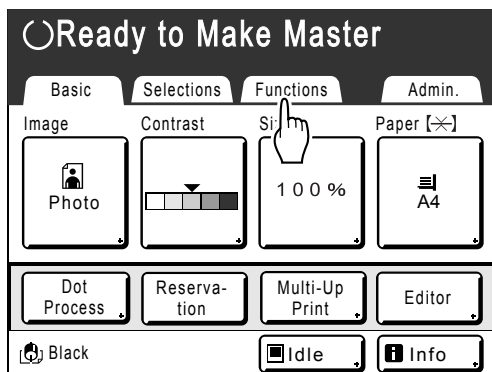

- 8** Touch [USB Job List].

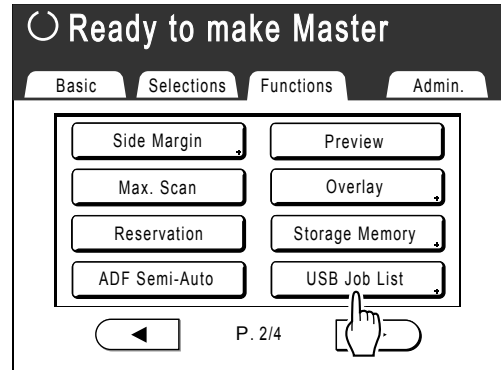

The USB Job List Screen (with “Non-ID Print”) is displayed.

(The “ID Print Job” button is displayed on the screen.)

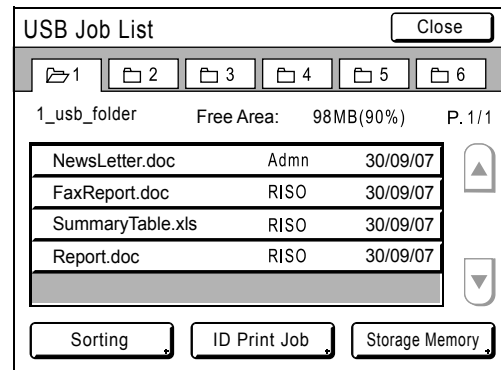

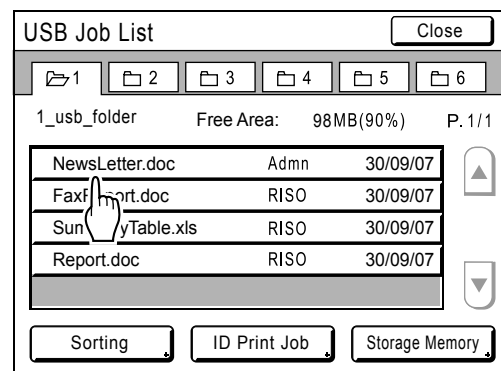

- 9** Touch the data to print.



The “USB Job List” retrieve screen is displayed. If you are selecting data stored in a different folder, touch that folder’s tab.

Note:

- To retrieve the ID print, touch **[ID Print Job]**.
- When “Management Level” is set to “Low/ Admin tab only” in the “User Management”, **[ID Print Job]** will not be displayed.
- If the stored data is not shown on the screen, touch  or  to display it.

10 Confirm the retrieved data.

Use the thumbnail to check whether the specified data is the desired data or not.

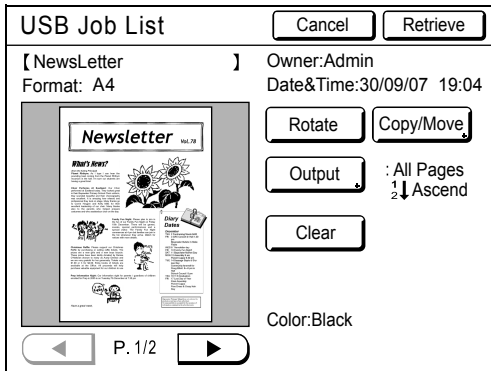

From the “USB Job List” retrieve screen, you can confirm retrieved data and specify output settings. See p.192 for operational details.

11 Touch [Retrieve].

The data is retrieved and the Storage Mode Basic Screen appears.

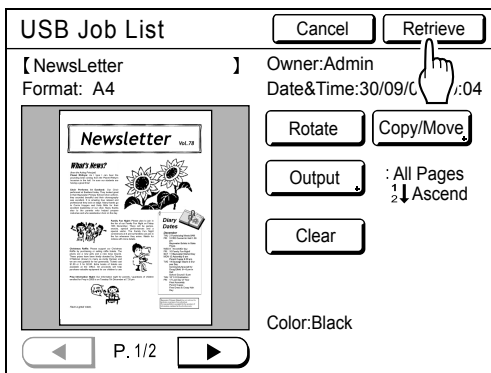

The following screen appears.

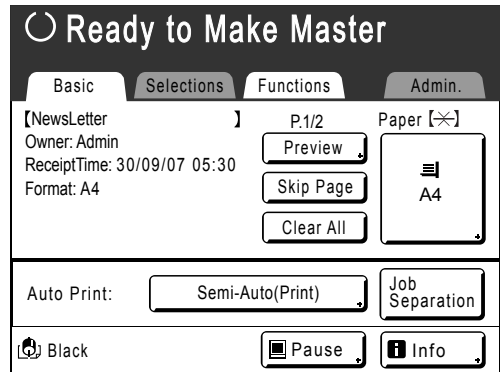

Note:

- You can change the output directions and stop timing settings on Master Making Basic Screen. For details, see p.49 and p.51

12 Enter the number of copies using the Print Quantity Keys.

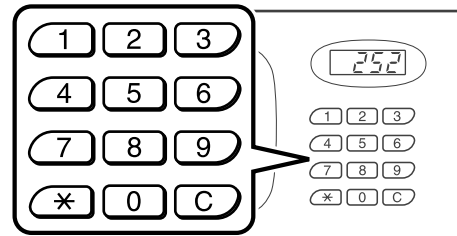

The entered number is displayed on the Print Quantity Display.

13 Press the  key.

Data is printed. After this, follow the same operations for paper documents.

Changing Output Directions

Output can be controlled from the Master Making/Print Basic Screens.

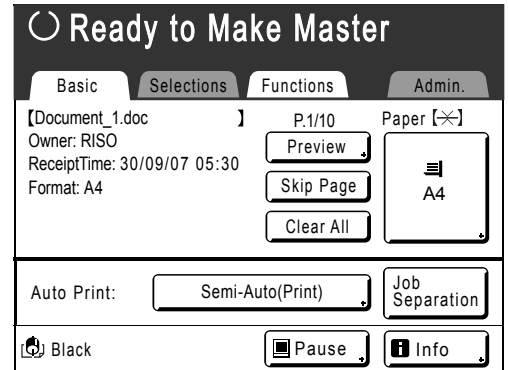

- **[Preview]**
You can check the master making image of the page currently awaiting creation.
- **Note:**
 - In "Preview", all received original data is displayed as a master making image. The outside of print area is not actually printed.
- **[Skip Page]**
Cancels a pending page, and start processing the next page. Use this button when current file has extra, unwanted pages.
- **[Clear All]**
Deletes all currently queued jobs. Use this button to delete a job sent by a mistake, or pending jobs no longer needed.



Important!:

- **[Skip Page]** and **[Clear All]** are disabled during master-making or printing processes. Press the  key to modify directions while master-making or printing is in progress. (In master-making process, the operation will stop after the master is made. In print process, the print job is halted.)

Note:

- Pressing either the  key or the  key while waiting for a command (under Ready to Make Master/Ready to Print screens) will delete the pending job.

When selecting [Skip Page]

1 Touch [Skip Page].

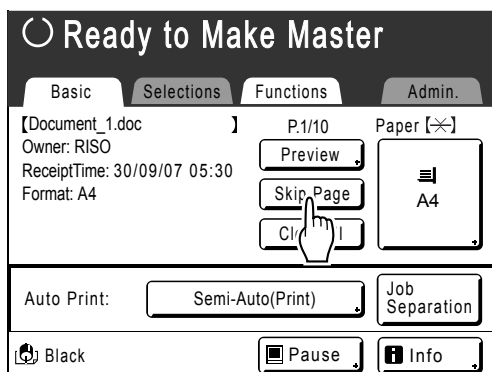

2 Touch [OK].

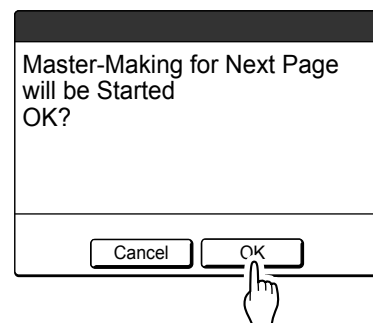

Stops processing the current page and moves on to process the next page.

When selecting [Clear All]

1 Touch [Clear All].

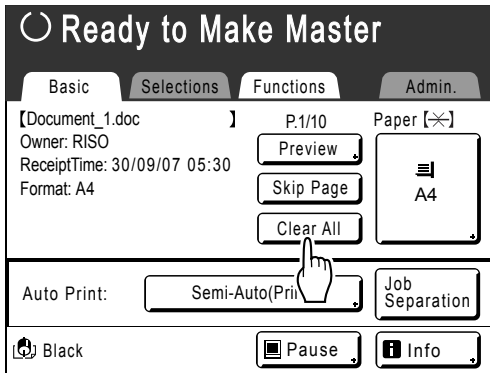

2 Touch [OK].

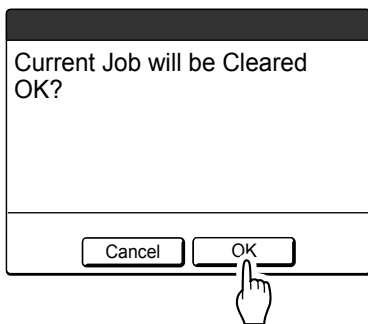

Clears current job.
Starts processing next data in queue.

Changing Stop Timing

Stop timing as set on the printer driver takes priority by default. However, the settings can be changed on the machine while the machine is halted.

Note:

- If “Process” is set to “Full Auto” in the Printing Property of the Printer Driver, press the  key to stop the operation and to make changes.

1 Touch the “Auto Print” function button.

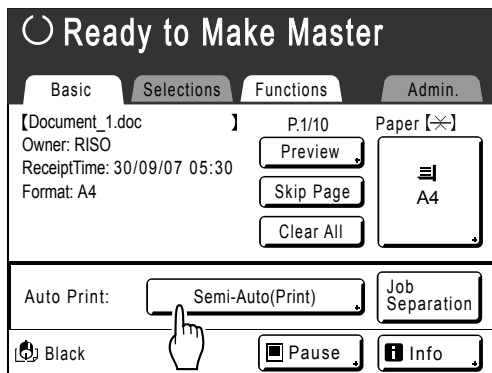

The Auto Print screen appears.

2 Select the desired function.

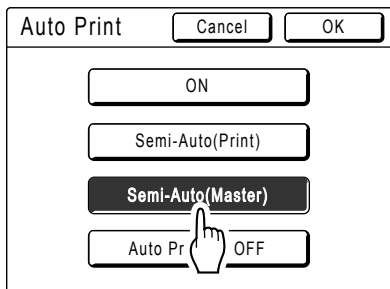

- **[ON]:** Makes a master then automatically prints.
- **[Semi-Auto(Print)]:** The operation stops before making a master.
- **[Semi-Auto(Master)]:** After a master is made and a proof copy is printed, the operation stops.
- **[Auto Process OFF]:** Stops before making a master, and then again before printing.

Note:

- See [p.44](#) for details regarding operations after each stop.

3 Touch [OK].

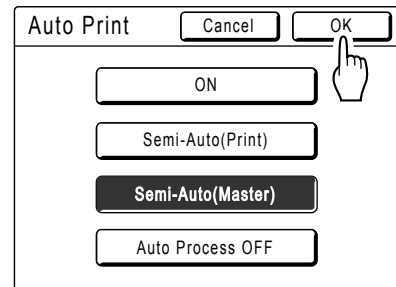

The following screen appears.

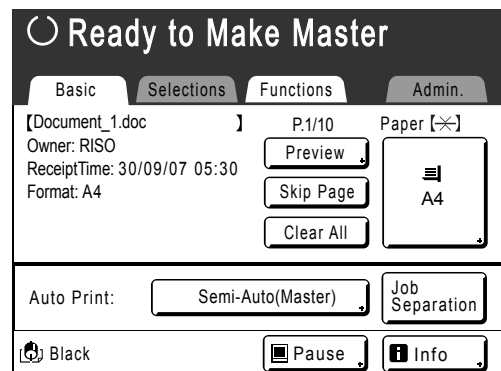

Returns to Basic Screen. Auto Print setting is updated.

Functions for Master-Making

Selecting Image Processing Mode [Image]

In order to make a master best suited for the original document, select an appropriate mode depending on whether original contain only text, photo, or both of them.

Note:

- Default Image Processing mode can be set on the Admin. screen.
 ↪ p.163

1 Touch [Image] on the Master Making Basic Screen.

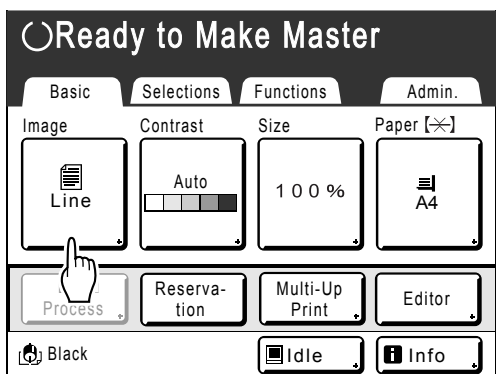

Touch **[Photo]**, **[Duo]** or **[Pencil]** to select more detailed settings.

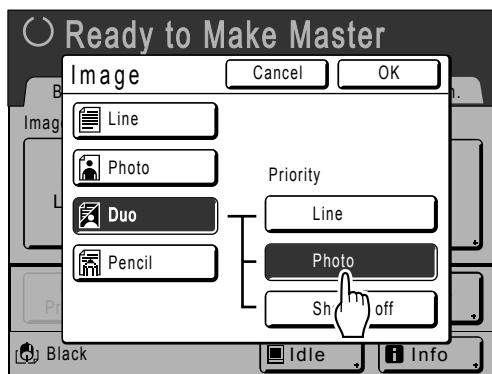

2 Select the appropriate Image Processing mode for the original.

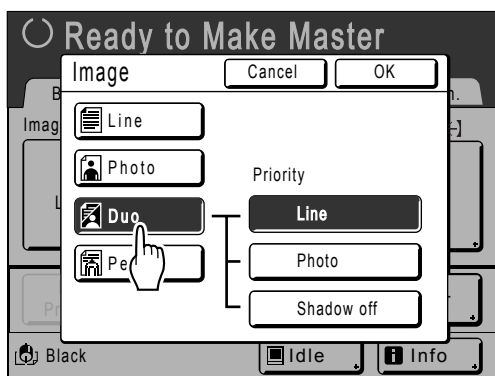

- **[Line]**: Only text contained; e.g., text document, newspaper
- **[Photo]**: Only photos contained
- **[Duo]**: Both text and photos contained
- **[Pencil]**: Pencil drawings or lightly printed documents

Image (Detailed settings)	Description
[Photo]	
Standard	Select for photos other than [Portrait] or [Group] .
Portrait	Use this setting for pictures of one or two individuals from the bust up. This type of image processing is particularly good for printing photos of faces.
Group	This setting is for group photos that are over-exposed. This process is effective for restoring facial features that have become washed out by a flash. The Group setting is not for photos with faces that are overly dark. It may be more effective to select [Standard] for such photos.
[Duo]	
Line	Select to print small text clearly.
Photo	Select to print photos more clearly (brightly).

Image (Detailed settings)	Description
Shadow off	Select to clear the background color (colour) of the dark-color (colour) originals (such as newspapers). [Shadow off] is selectable aside from [Line] and [Photo] .
[Pencil]	
Darker	Select to print faint originals clearly.
Lighter	Select to print cut-and-pasted pencil drawings with shadows.

Note:

- Some functions are not available in certain Image Processing mode settings.

	Line	Photo	Duo	Pencil
Dot Process	—	✓	✓	—
Contrast (Auto)	✓	—	—	—
Contrast (1-5)	✓	✓	✓	✓

✓ : available — : not available

- In the **[Line]** mode, when **[Contrast]** is set to **[Auto]**, the background color (colour) of the original is automatically deleted.
☞ p.54

3 Touch [OK].

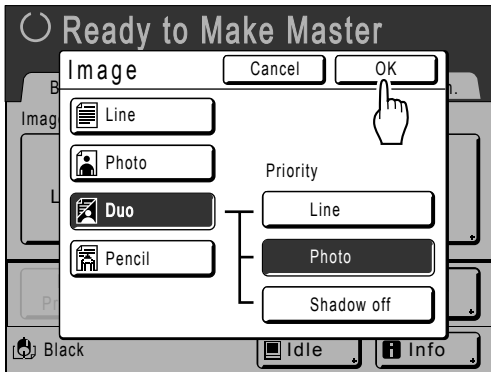

The following screen appears.

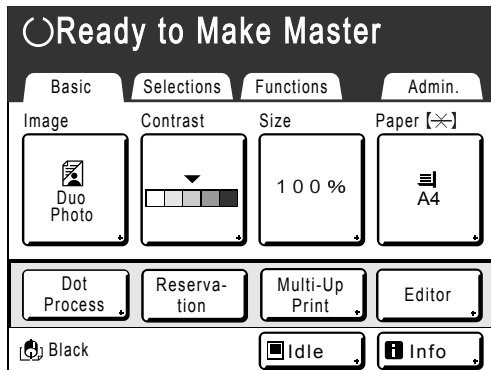

Returns to the Master Making Basic Screen. Image Processing mode is updated.

Selecting Scanning Contrast for the Original [Contrast]

Scanning contrast can be adjusted to accommodate the density of the original. Specify by selecting Auto or numeric levels (1-5). In the Auto mode, "Contrast" is automatically adjusted to the background color (colour) of the original for printing.

Important!:

- "Auto" is available only when Image Processing mode has been set to "Line".
 ☞ p.52

Note:

- Default Scanning Contrast can be set on the Admin. screen.
 ☞ p.163

1 Touch [Contrast] on the Master Making Basic Screen.

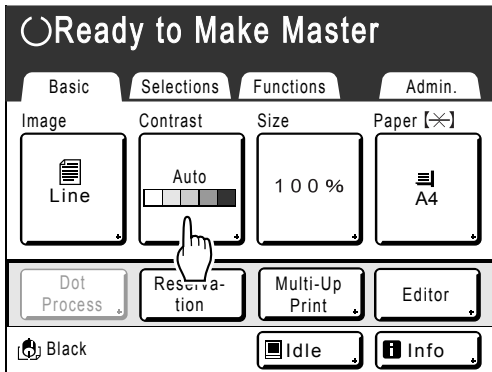

2 Touch the desired contrast or [Auto].

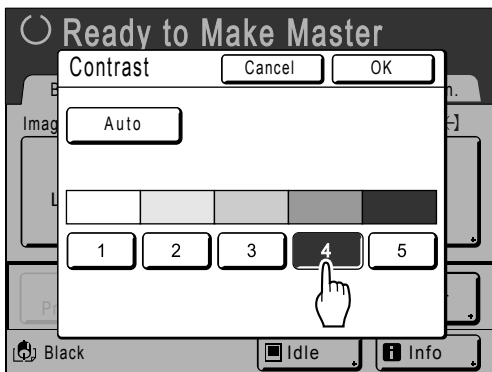

Levels of scanning contrast

- 1) [Lightest square]: Lightest
- 2) [Lighter square]: Lighter
- 3) [Standard square]: Standard
- 4) [Darker square]: Darker
- 5) [Darkest square]: Darkest

3 Touch [OK].

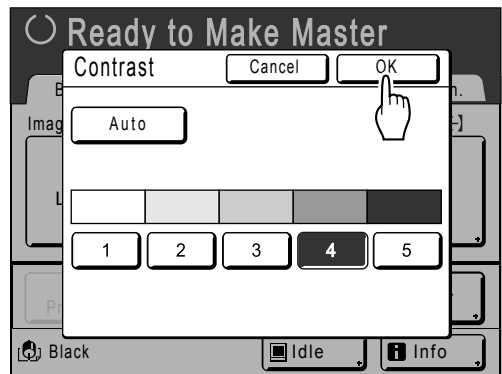

The following screen appears.

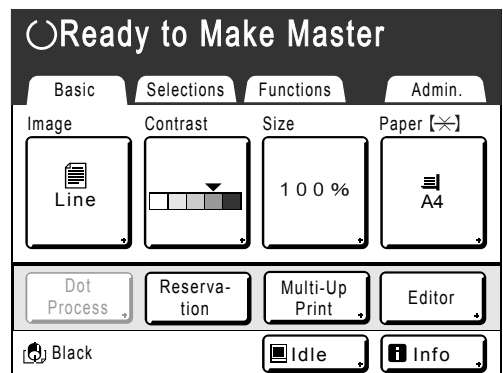

Returns to the Master Making Basic Screen. "Contrast" is updated.

Enlarging/Reducing Originals

[Standard Ratio] [Margin+] [Free] [Zoom]

The document can be printed enlarged or reduced. The following methods can be used to enlarge/reduce the original.

◆ Standard Ratio

Enlarging or reducing a standard-sized original (A4, B5, Letter, Legal, etc.) to print in another standard size.

◆ Auto*

The original can be automatically enlarged or reduced and printed according to the paper size in the Paper Feed Tray.

*"Auto" is available only when the originals are placed in the ADF unit (Option).

◆ Margin+

Reducing the original slightly. This feature is useful when allowing binding margins, or when text or diagram extends beyond the printing area.

☞ p.18

Specify reduction rate of 90%-99% on the Admin. screen.

☞ p.164

Note:

- "Margin+" and "Standard Ratio" can be selected at the same time.

◆ Free

The top/bottom and left/right of the original can be enlarged or reduced and printed as desired.

Specify the enlarging/reducing between 50% and 200% in increments of 1%.

◆ Zoom

Allows you to specify numerical resize ratio.

Specify the enlarging/reducing between 50% and 200% in increments of 1%.

Note:

- To avoid paper jam, flipping or ink smudges on the back side by design the machine does not print too close to the edge. The top edge in particular needs 5 mm ($\frac{3}{16}$ ") of margin space.

☞ p.18

5 mm ($\frac{3}{16}$ ") wide area on the top edge (marked ▲) of the Glass Platen or the ADF unit (Option) cannot be scanned, regardless of enlargement or reduction settings.

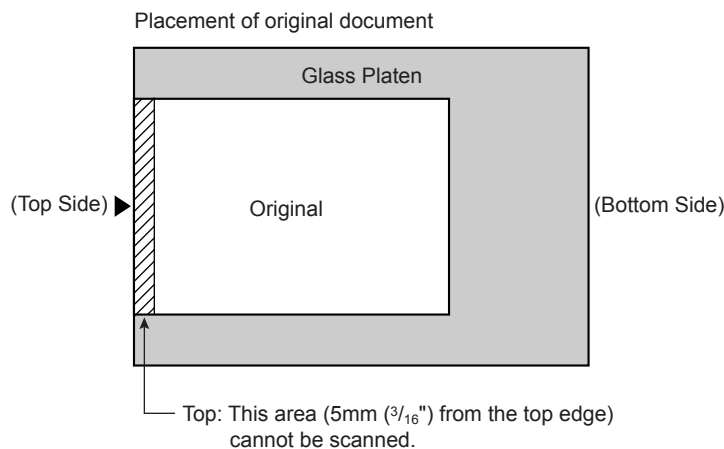

- Do not position the original within 5 mm ($\frac{3}{16}$ ") of the top edge, or the top edge of its printed image will be cut off. This 5 mm ($\frac{3}{16}$ ") margin will remain even in the "Max. Scan" setting.
☞ p.86
- If the original document has no margin on its top edge, the top 5 mm ($\frac{3}{16}$ ") of its print will be cut off even when "Margin+" is selected. Move the original about 5 mm ($\frac{3}{16}$ ") inwards from the top edge of the glass platen or the ADF unit (Option) and reduce the size.

Enlargement and Reduction by Standard Ratio

[Standard Ratio] [Margin+] [Auto]

1 Touch [Size] on the Master Making Basic Screen.

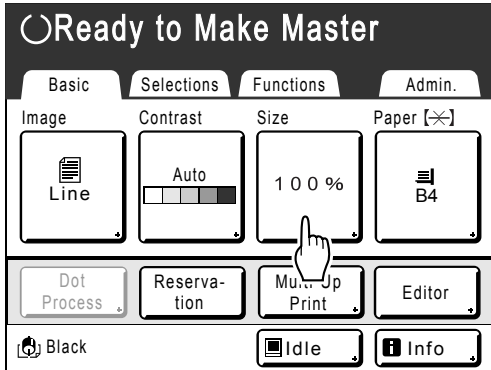

2 Touch the button corresponding to the desired size.

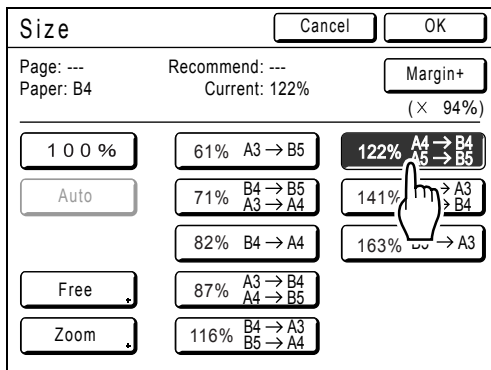

Touch **[100%]** to restore the original size.
For original with no margins, touch **[Margin+]** before printing.

Important!:

- The “Margin+” setting is not available when “Auto”, “Free” or “Zoom” is selected.
- “Auto” is available only when the originals are placed in the ADF unit (Option).

Note:

- If “Standard Ratio” and “Margin+” are used together, the “Current” field will indicate the combined result of “Standard Ratio” × “Margin-Plus Rate”.
- When placing the originals in the ADF unit (Option), the page size (original size) and recommended size are displayed. When placing the originals on the glass platen, “---” is displayed.

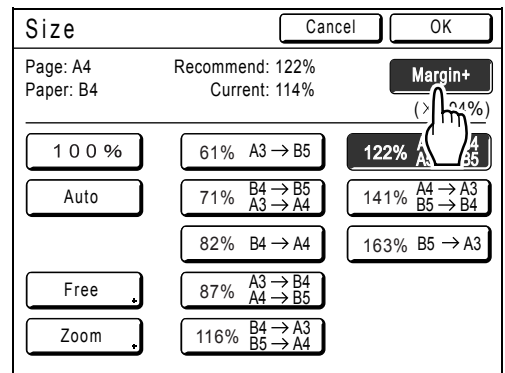

3 Touch [OK].

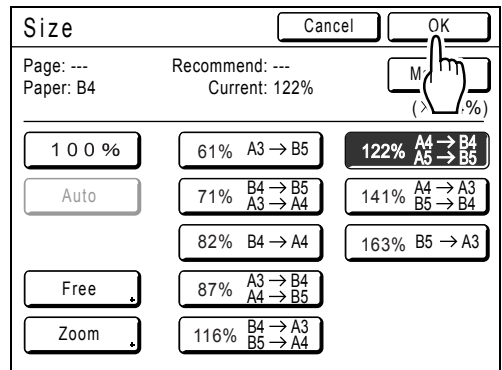

The following screen appears.

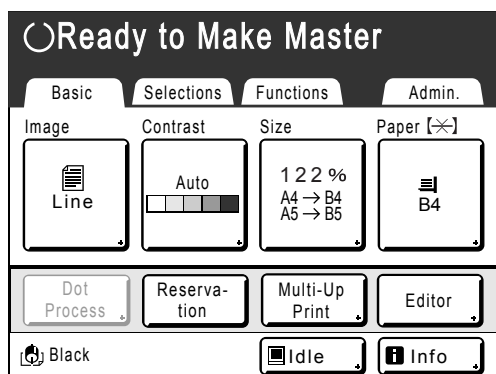

Returns to the Master Making Basic Screen.
"Size" is updated.

Enlargement/Reduction of a Changed Aspect Ratio [Free]

1 Touch [Size] on the Master Making Basic Screen.

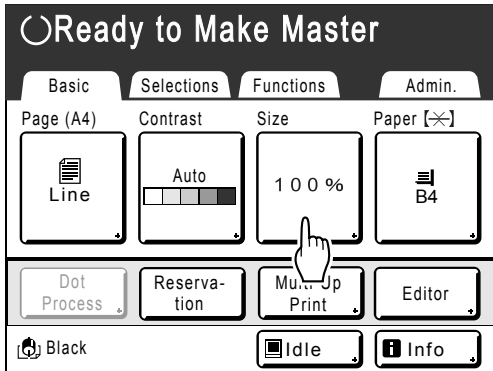

2 Touch [Free].

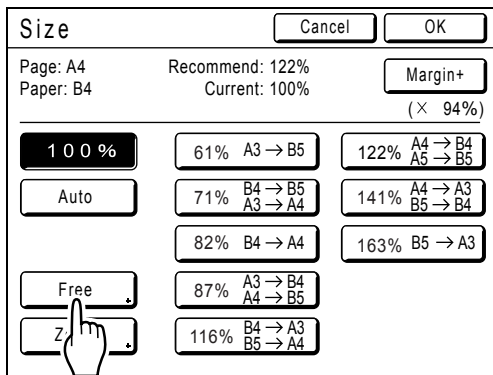

3 Touch ▲ or ▼ to adjust enlarging/reducing in horizontal or vertical directions.

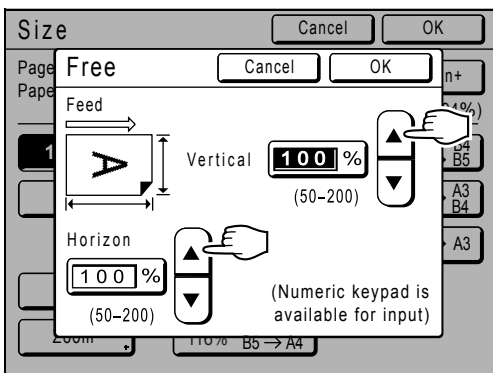

The reproduction size can be increased/decreased in increments of 1%.

Note:

- Print Quantity Keys can also be used to enter numbers.
- Press the **C** key to restore the original size (100%).

4 Touch [OK].

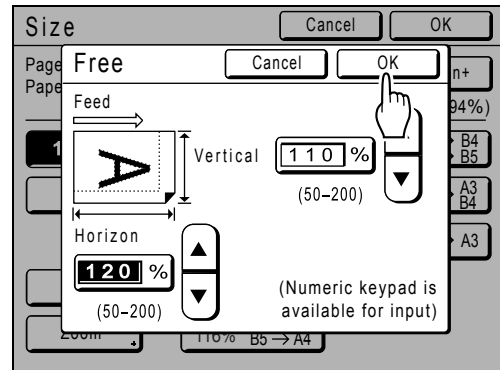

The following screen appears.

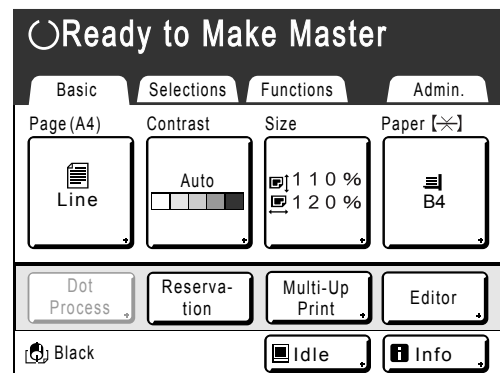

Returns to the Master Making Basic Screen. "Size" is updated.

Enlarging and Reducing with the Zoom Function [Zoom]

1 Touch [Size] on the Master Making Basic Screen.

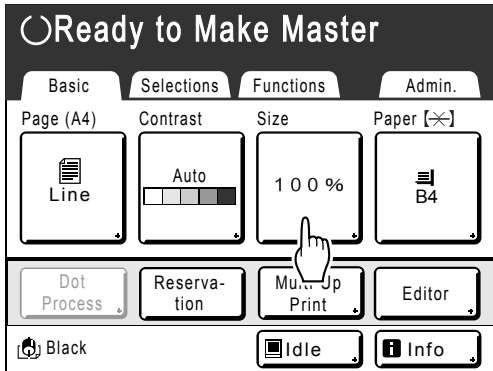

2 Touch [Zoom].

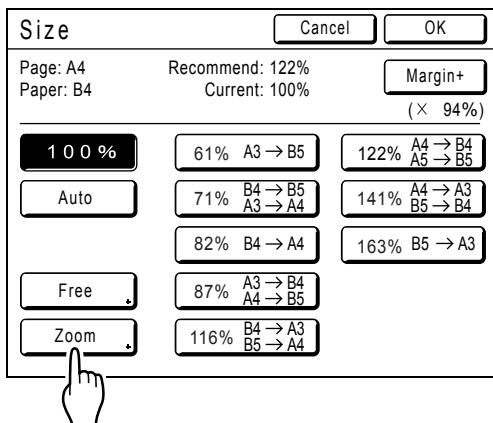

3 Touch ▲ or ▼ to change ratio.

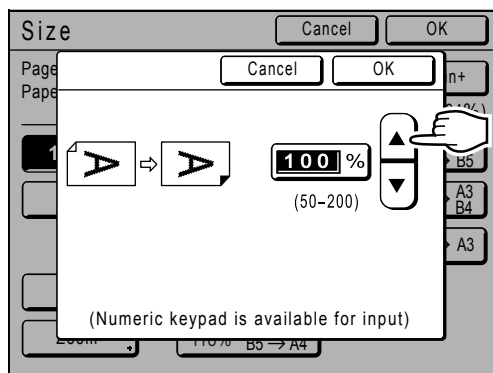

The reproduction size can be increased/decreased in increments of 1%.

Note:

- Print Quantity Keys can also be used to enter numbers.
- Press the **C** key to restore the original size (100%).

4 Touch [OK].

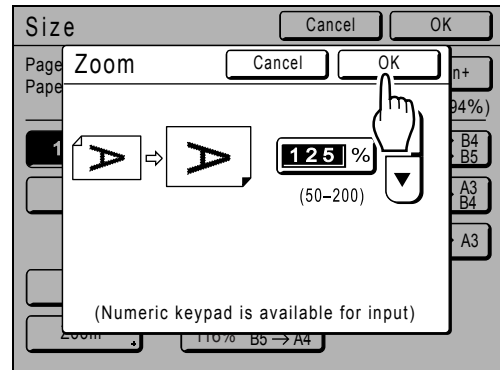

The following screen appears.

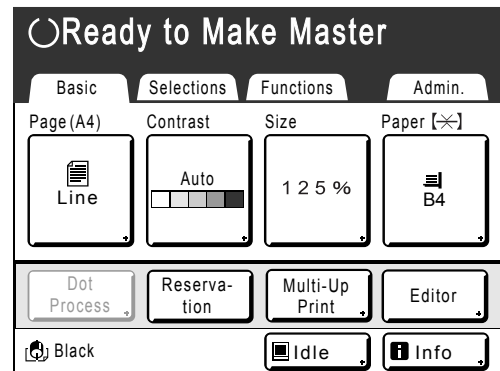

Returns to the Master Making Basic Screen. "Size" is updated.

Using Custom-Sized Paper [Paper]

The machine automatically detects standard-sized paper in the Paper Feed Tray to create a correct size master for printing. However, because non-standard paper sizes cannot be detected, they must be manually specified before a master can be made.

Important!:

- Custom paper size must be registered on the Admin. screen. Failure to do so may make an incomplete master.
 ↗ p.174

1 Touch [Paper] on the Master Making Basic Screen.

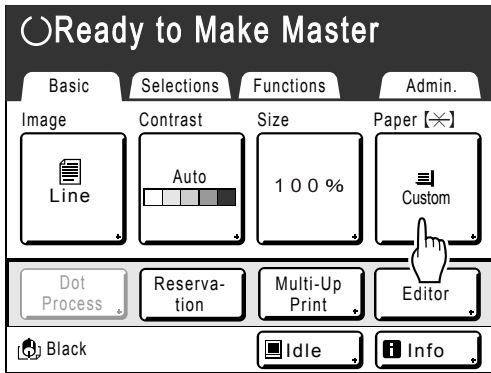

2 Touch the desired paper size.

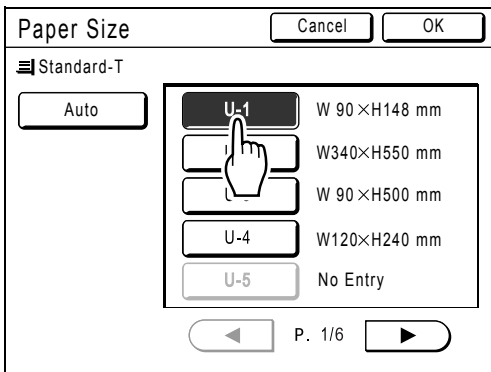

Note:

- Touch **[Auto]** to use standard-sized paper.

3 Touch [OK].

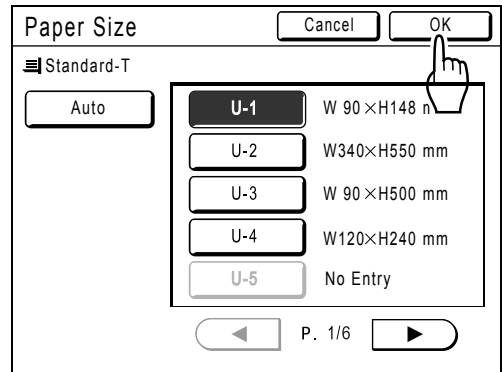

The following screen appears.

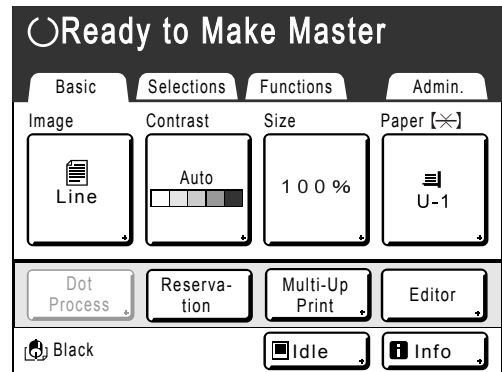

Returns to the Master Making Basic Screen. "Paper size" is updated.

Automatic Printing [Auto-Process]

Master-making and printing can be performed automatically in sequence.

When “Auto-Process” is selected, simply enter the number of copies to print, then press the  key.

Note:

- When printing is completed, Print Quantity will restore the number originally entered.
- On the Admin. screen, you can make such a setting that “Auto-Process” is always set to ON when you reset or start the machine.

☞ p.163

Press the  key.

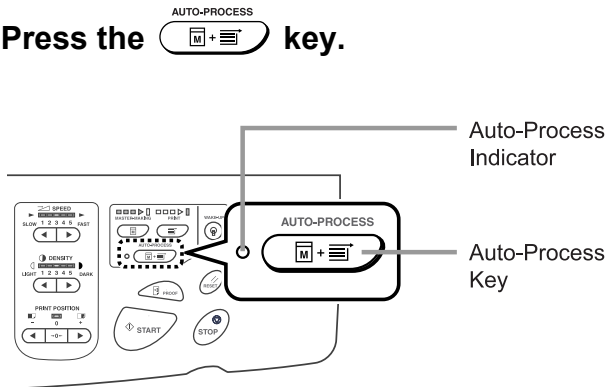

The Auto-Process indicator turns on.

Note:

- To cancel “Auto-Process”, press the  key again. The indicator turns off.
- If multiple originals are placed in the ADF unit (Option) and “Auto-Process” is set to ON, all originals will be printed automatically.

Processing Photos with Dot Screen

[Dot Process]

“Dot Process” function processes photo originals with dot screening in order to print more clearly. Select from four types of dot patterns.

Important!:

- “Dot Process” is not available when Image Processing mode has been set to “Line” or “Pencil”.

1 Touch [Functions] on the Master Making Basic Screen.

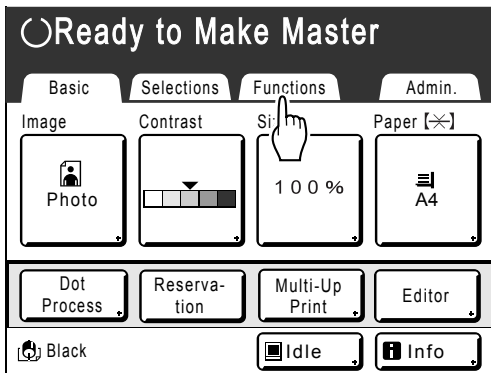

2 Touch [Dot Process].

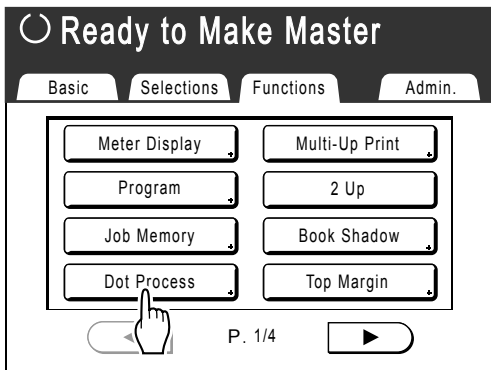

3 Select a dot pattern.

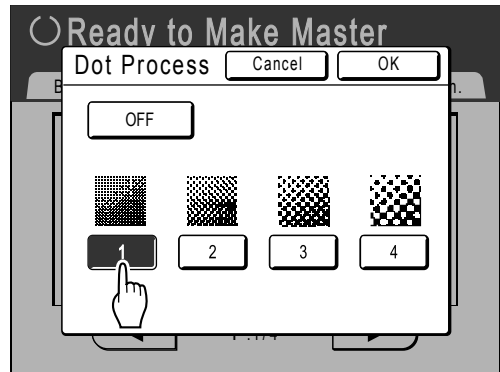

Number	1	2	3	4
Equivalent Lpi	106	71	53	34

Note:

- Touch [OFF] to cancel the “Dot Process”.

4 Touch [OK].

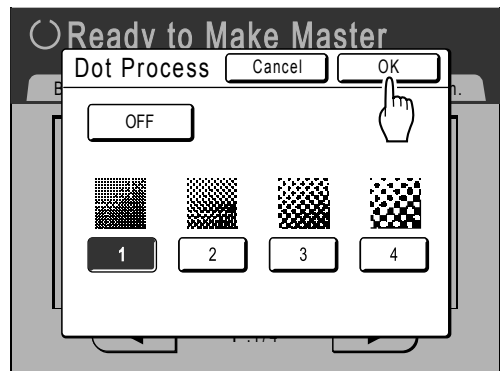

The following screen appears.



Returns to the Functions screen.
"Dot Process" setting is updated.

Saving Ink [Ink Saving]

Selecting “Ink Saving” makes a master that requires less ink when printing.

Important!:

- This function is not available at the time of printing. It must be selected before the master-making process is started.
 - The ink consumption save process may result in lighter prints than usual.
 - “Contrast” and “Print Density Adjustment” functions are not available when “Ink Saving” is selected.
- ☞ p.54
☞ p.89

1 Touch [Functions] on the Master Making Basic Screen.

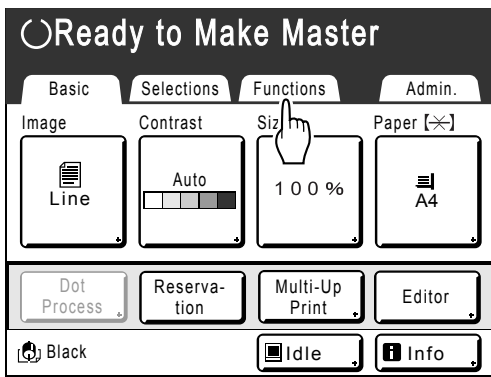

2 Touch [Ink Saving].



“Ink Saving” is set.

☞ “Ink Saving” will appear in the message area.

Note:

- “Ink Saving” is a useful function for master-making. Even if this function is set or canceled during printing, it doesn't reflect on the master that is currently rolled around the Print Drum (Cylinder). The setting will be reflected in the next master.

Printing Multiple Originals on One Sheet

[2 Up] [Multi-Up Print]

“Multi-Up” function prints multiple originals on one sheet.

◆ 2 Up

Prints two copies of the same original side-by-side on one sheet of paper.

Note:

- Using the ADF unit (Option), two different originals can be printed side-by-side on one sheet of paper.

◆ Multi-Up Print

One or multiple originals (up to 4) can be printed on a single sheet of paper.

The border lines between the originals (shadows) will not be printed and you can get a clearer copy.

“Multi-Up Print” has the following three types:

- Single-Original: A single original is printed multiple times.
- Multiple-Original: Multiple originals are printed multiple times.
- Multi-Up Tickets: You can print multiple long, thin custom originals such as tickets.

Single-Original and Multiple-Original can print in quantities of 2, 4, 8 and 16 respectively.

Important!:

- Use standard-sized paper when using the “Multi-Up” function. With custom-sized paper placed, you cannot perform “Multi-Up” printing even when the size is stored on the Admin. screen.

Note:

- “2 Up” and “Multi-Up Print” functions cannot be used with the following functions.
 - Top Margin
 - Book Shadow
 - Side Margin
 - Size (Auto)
 - Format (Auto) (in Scan Mode)
- If you change the “Image” setting between originals in Multiple-Original, you cannot use “Ink Saving”.

Original Orientation and Print Results

The orientation of the original differs depending upon the number of images. The orientation and print results for each possibility is shown below.

2 Up

Prints two copies of the same original side-by-side on one sheet of paper.

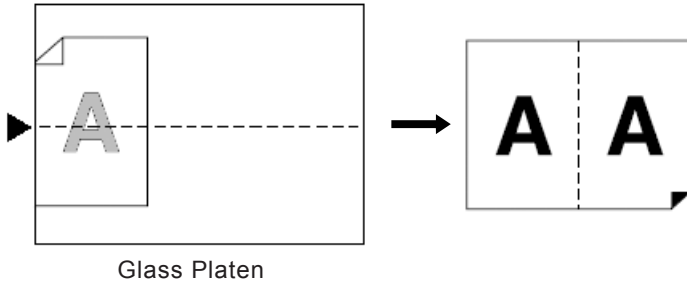

Multi-Up Print

For Single-Original and Multiple-Original:

Note:

- When "Multiple-Original" is used in Multi-Up Print, the actual number of pages to be scanned is specified. In the case that the actual number of pages in the document is less than the number of pages specified in the mode settings, set an equivalent number of blank pages in the machine to make up for the specified number. (For example, if you want to make eight pages and there are only three originals, add a blank page to the originals and set the four sheets for scanning.)

◆ 2 Up (2 on 1)

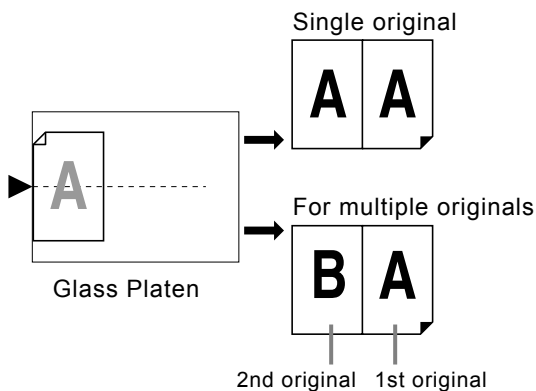

Up to 2 originals can be scanned.

◆ 4 Up (4 on 1)

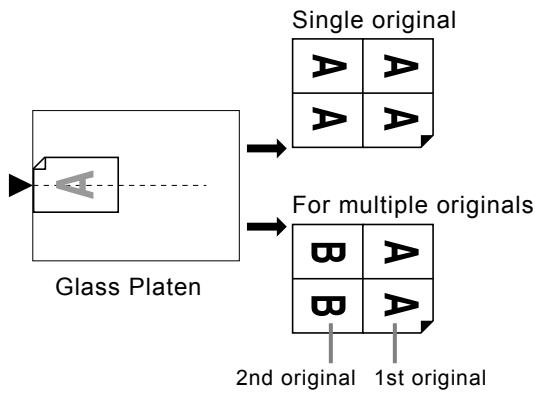

Up to 2 originals can be scanned.

◆ 8 Up (8 on 1)

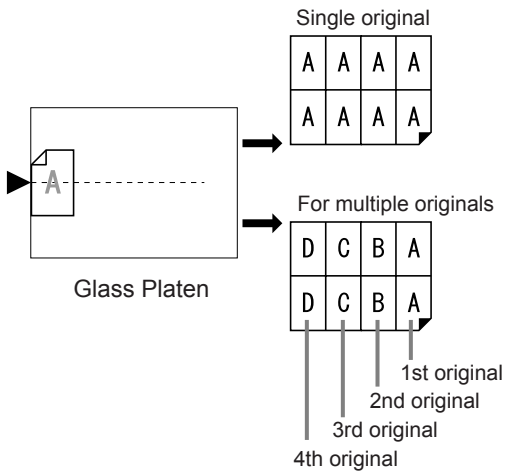

Up to 4 originals can be scanned.

◆ 16 Up (16 on 1)

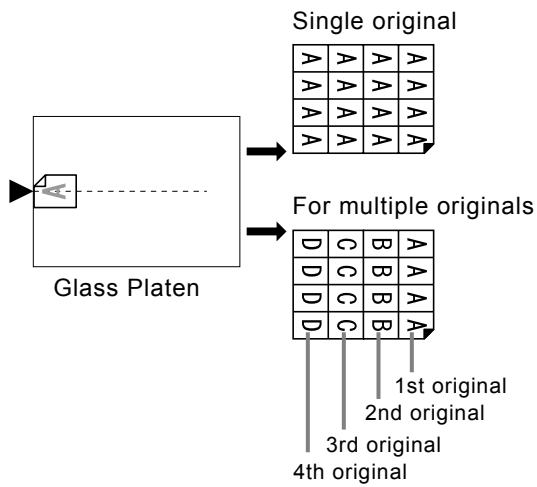

Up to 4 originals can be scanned.

◆ For Multi-Up Tickets:

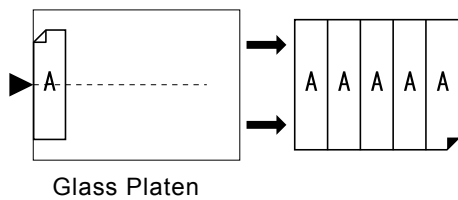

“Multi-Up Tickets” cannot be used with multiple originals.
The number of images printed is determined by the width of the ticket.

Margin

Leave a margin of at least 5 mm ($\frac{3}{16}$ ") on the top edge of the Glass Platen or the ADF unit (Option). Allowing a proper margin is critical in well-balanced Multi-Up positioning.

☞ p.18

Note:

- A margin on the top edge will remain regardless of enlargement or reduction settings.

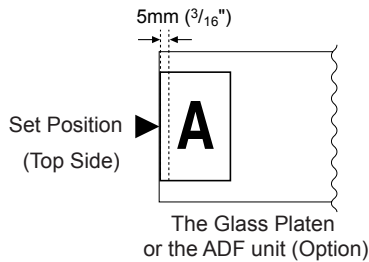

Orientation of Print Paper

Always place paper in the Paper Feed Tray as shown below.

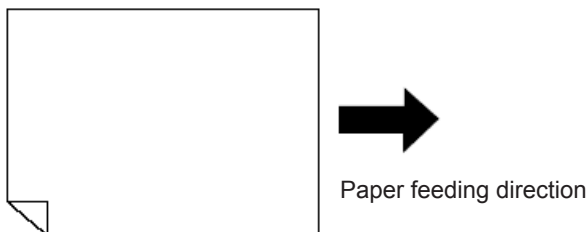

Multi-Up Interval

“Multi-Up” performs scanning for the number of sheets.

The interval between the first scan and the second scan is called “Multi-Up Interval”.

Replace originals or change settings for the second scan during the “Multi-Up Interval”.

Note:

- Default “Multi-Up Interval” can be set on the Admin. screen. The factory default is 15 seconds. ☞ p.165

2 Up Operation

1 Set the original and print paper.

Important!:

- Pay attention to the orientation of the original. For “2 Up”, make sure to place the original as shown below.
- The same is true when using the ADF unit (Option).

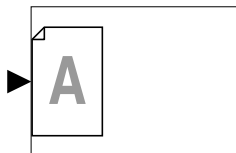

- Make sure to load paper as shown below.

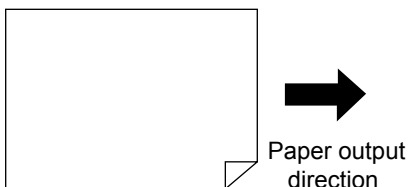

Note:

- With the ADF unit (Option) you can print two different originals side by side on a single sheet of paper (2 in 1 printing). Set the two originals one above the other.
- To print two copies of the same original side by side on a single sheet of paper (2 Up printing), set the original on the Glass Platen.

2 Touch [Functions] on the Master Making Basic Screen.

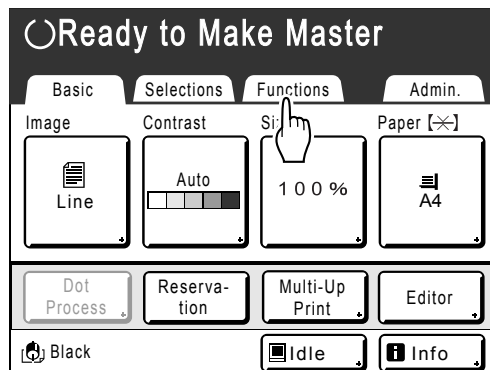

3 Touch [2 Up].

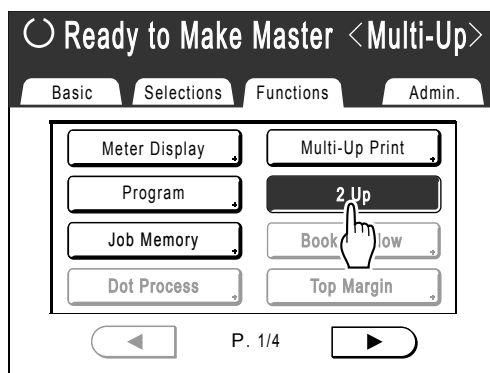

4 Make necessary settings.

Make various settings as needed.
The enlarging/reducing needs to be set depending on the combination of the original size and printing paper size.

		Original			
		A4	B5	A5	B6
Printing Paper	A3	100%	116%	141%	163%
	B4	87%	100%	123%	142%
	A4	71%	82%	100%	116%
	B5	61%	71%	87%	100%

		Original			
		A6	B7	A7	B8
Printing Paper	A3	200%	---	---	---
	B4	173%	200%	---	---
	A4	138%	163%	200%	---
	B5	122%	141%	173%	200%

		Original	
		Letter	Statement
Printing Paper	Ledger	100%	127%
	Legal	77%	100%
	Letter	66%	100%
	Statement	50%	66%

5 Press the key.

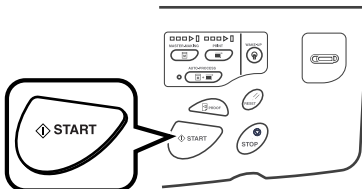

Starts scanning of the original.

Operation for Multi-Up Printing

1 Set the original and print paper.

Important!:

- Pay attention to the orientation of the original. p.66
- Make sure to load paper as shown below.

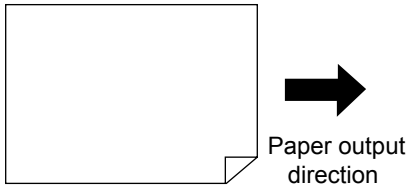

Note:

- It is convenient to place all originals in the ADF unit (Option) when using the “Multiple-Original” mode. p.38

2 Touch [Functions] on the Master Making Basic Screen.

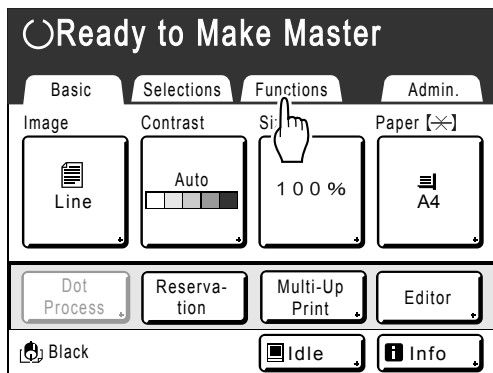

3 Touch [Multi-Up Print].

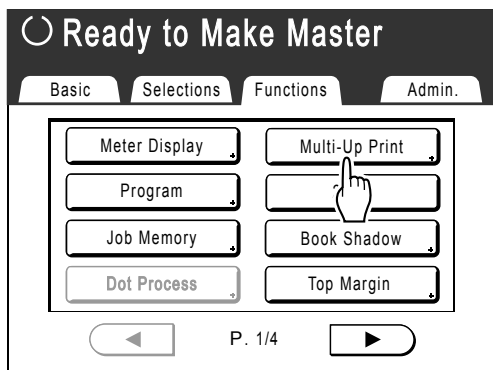

4 Select a Page size to use.

Touch the button to match the original size and touch **[Next>]**.

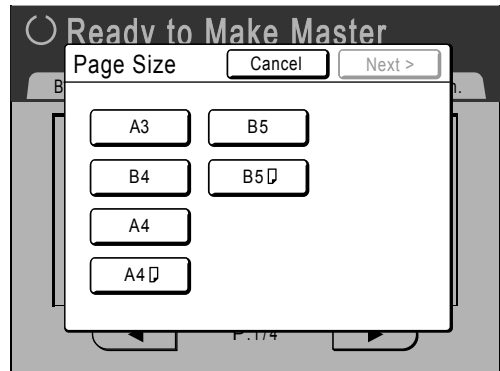

The enlarging/reducing is automatically set and the Multi-Up Print screen is displayed.

5 Touch [Single] for Single-Original, touch [Multiple] for Multiple-Original.

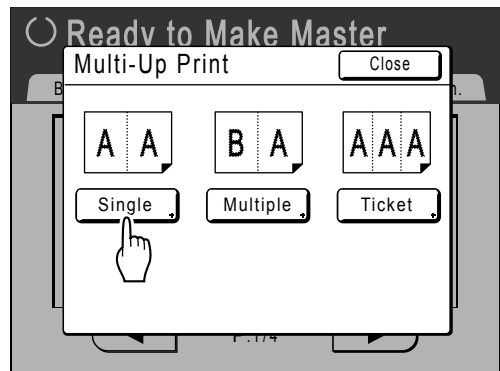

Except for the original placement method, operations for “Single-Original” and “Multiple-Original” are basically the same. This example is for “Single-Original”.

6 Touch the button of the number of images to use.

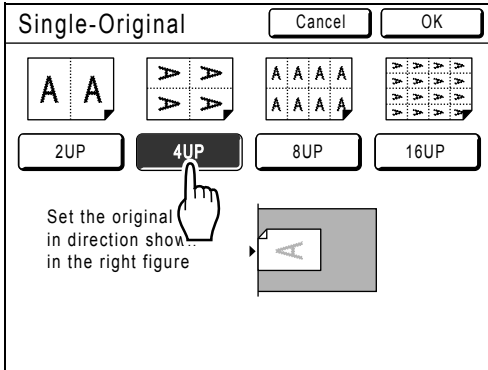

To cancel the "Multi-Up Print" settings or return to the Functions screen, touch **[Cancel]**.

7 Touch [OK].

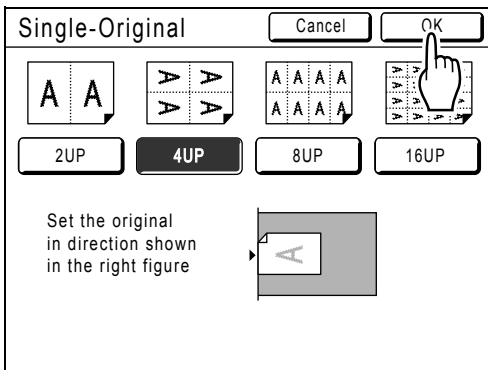

The following screen appears.

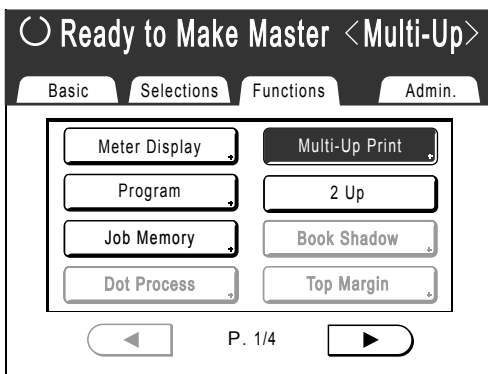

Returns to the Functions screen.
"Multi-Up Print" setting is updated.

8 Make necessary settings.

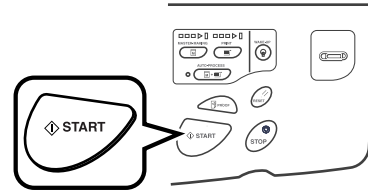

Make various settings as needed.

9 Press the  key.



Scanning of the original starts.

Important!:

- After displaying the message, "Place Another Original and Press Start Key To Cancel, Press Stop Key" the machine waits for the next original to be loaded. Set the next original and press the  key while waiting (interval) time. Press the  key to cancel the "Multi-Up Print" mode.
- The Glass Platen and the ADF unit (Option) cannot be used at the same time. If using the Glass Platen to scan the first sheet of the original, you must continue to use the Glass Platen to scan the rest of the original.

Note:

- When "Multiple-Original" is used in Multi-Up Print, the actual number of pages to be scanned is specified. In the case that the actual number of pages in the document is less than the number of pages specified in the mode settings, set an equivalent number of blank pages in the machine to make up for the specified number. (For example, if you want to make eight pages and there are only three originals, add a blank page to the originals and set the four sheets for scanning.)
→ p.66 "Original Orientation and Print Results"
- When using the "Auto Process" setting, printing will continue automatically when originals are set in the ADF unit (Option).
- When "Ink Saving" is turned ON, the Image Processing Mode cannot be changed between individual originals.
- To cancel a "Multi-Up Print" setting once it has been confirmed, follow steps 2 and 3, touch **[OFF]** and then **[OK]** on the screen.

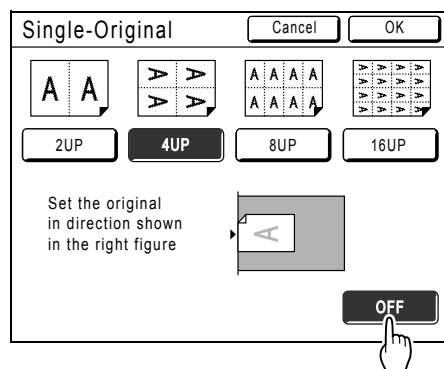

Operation for Multi-Up Tickets

For “Multi-Up Tickets”, the specification of the short edge size of the original (the width) is used to calculate the number of images that can be printed on one sheet of paper (long edge of the print paper divided by ticket width). A ticket width of between 50 mm (2”) and 210 mm (8.3”) can be specified.

Ex.)

Ticket width 50 mm (2”)

Long edge of the print paper 297 mm (11^{11/16}”) (A4 size)

$297 \div 50 = 5$ with a remainder of 47

In this example, 5 images print on one sheet of paper.

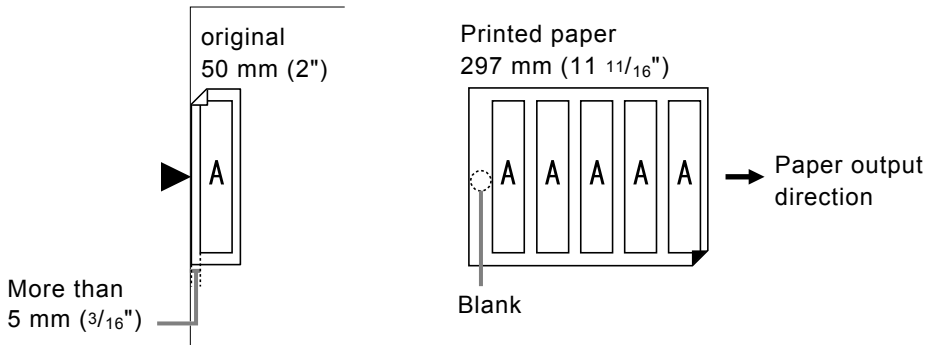

1 Set the original and print paper.

Place the original on the Glass Platen.

Important!:

- Pay attention to the orientation of the original.
☞ p.66

2 Touch [Functions] on the Master Making Basic Screen.

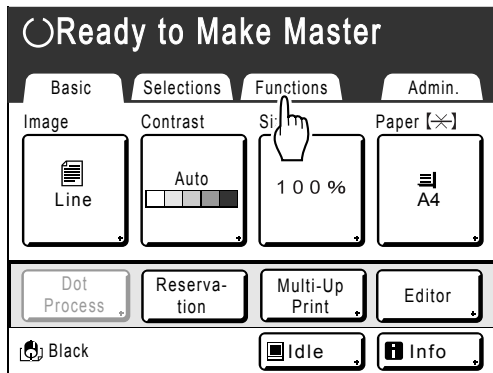

3 Touch [Multi-Up Print].

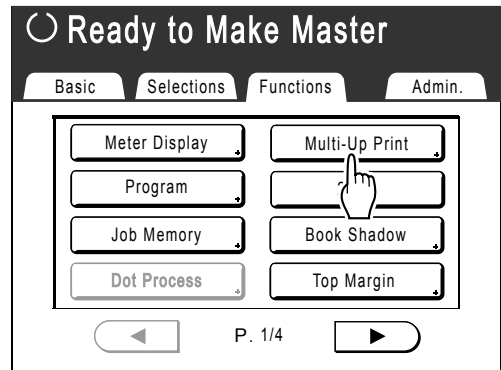

4 Select a Page size.

Touch either one of the Page size button and touch **[Next>]**.
 (In “Multi-Up Tickets”, the Page Size selection will not affect the rest of the procedures.)

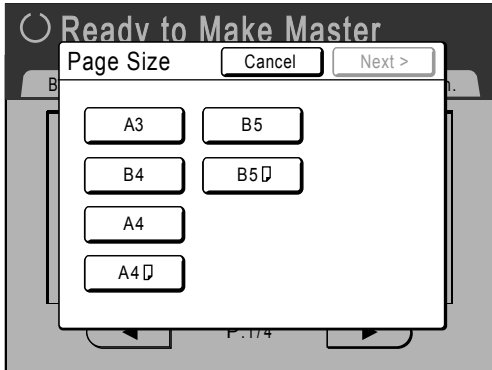

The Multi-Up Print screen is displayed.

5 Touch [Ticket].

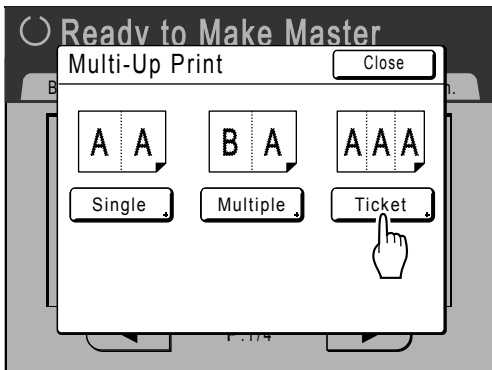

6 Touch ▲ or ▼ to specify the page width.

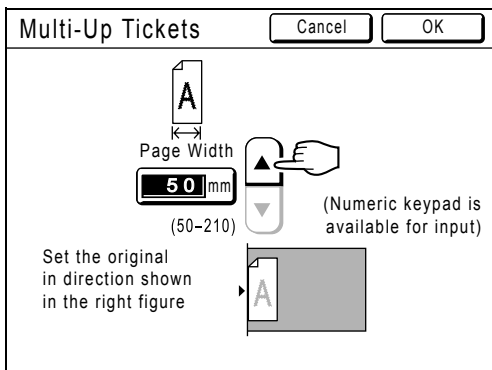

Important!:

- If you have enlarged/reduced size in step 8 (setting print functions), be careful about the following points.
 - Specify the ticket width after enlarging/reducing.
 - If you enlarged the size, make sure that the bigger size does not exceed the specified “Page Width” or the short edges of the print paper.
 - When enlarging, make sure to prepare paper that fits the enlarged size.

7 Touch [OK].

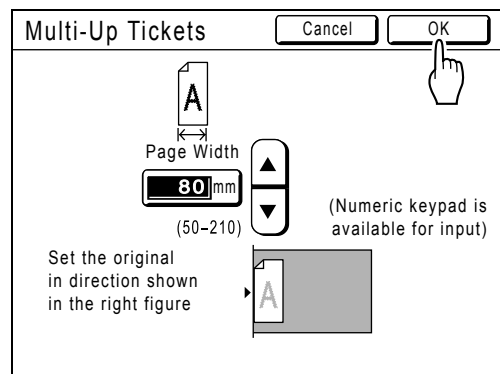

The following screen appears.

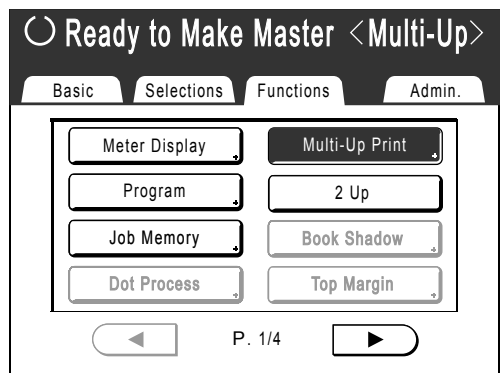

Returns to the Functions screen.
 “Multi-Up Tickets” setting is updated.

8 Make necessary settings.

Make various settings as needed.

9 Press the  **key.**

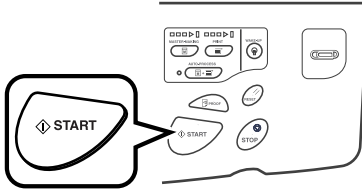

Starts scanning of the original.

Note:

- To cancel a “Multi-Up Print” setting once it has been confirmed, follow steps 2 and 3, touch **[OFF]** and then **[OK]** on the screen.

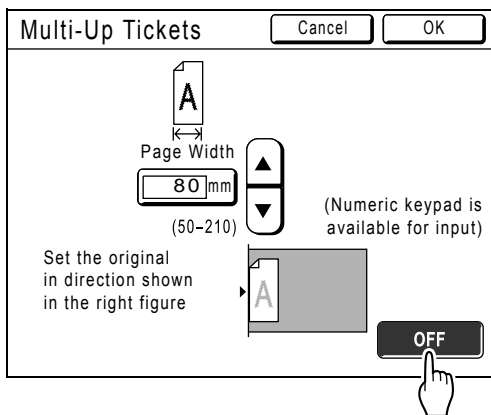

Printing from Bound Documents

[Book Shadow]

This function erases the binding “spine” shadow in the center when printing from such bound originals with facing as magazines and books.

The machine automatically detects the area to delete.

Important!:

- The original must be placed on the Glass Platen as shown below.

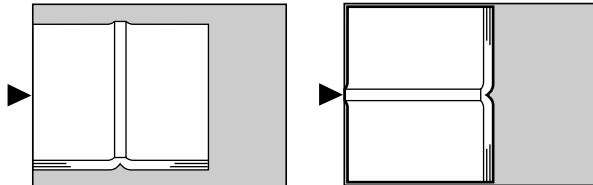

- The following image areas are also erased (or half-toned).
 - A continuous black image area (non-white) from the edge of the original

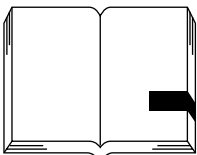

- A continuous black image area from the center of the original

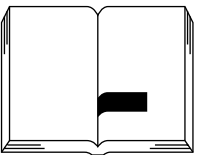

- “Ink Saving”, “Contrast (Auto)”, “Multi-Up Print” and “2 Up” functions are not available when “Book Shadow” is selected.

1 Touch [Functions] on the Master Making Basic Screen.

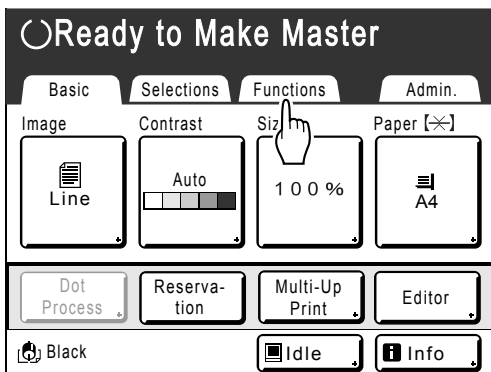

2 Touch [Book Shadow].

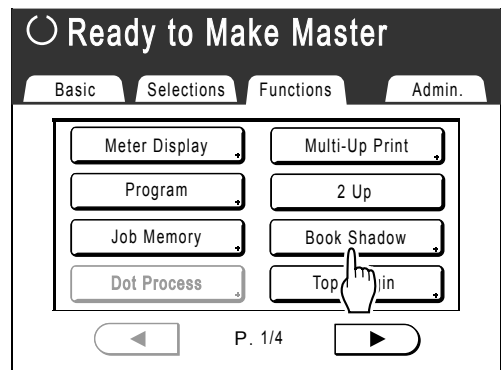

3 Touch the shadow processing method.

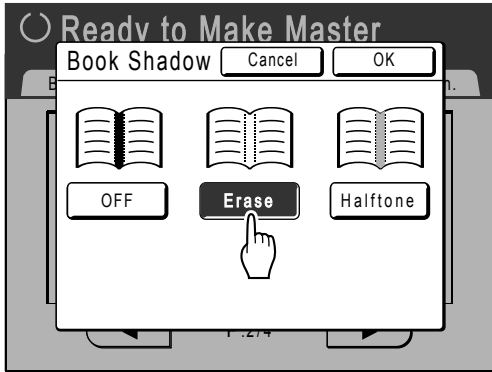

- **[Erase]:** Erases shadows near the center and around the original.
- **[Halftone]:** Photo processes the center shadow for a natural feel and deletes shadows that it can around the original.

4 Touch [OK].

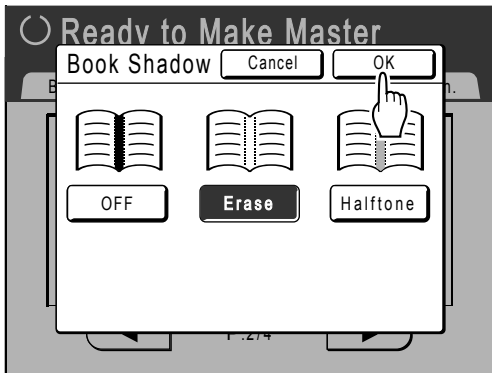

The following screen appears.

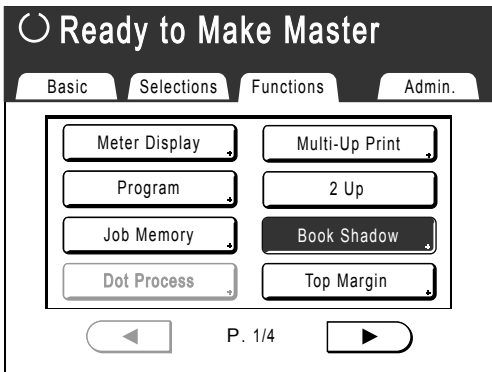

Returns to the Functions screen.
"Book Shadow" setting is updated.

Note:

- If you are scanning a thick book such as an encyclopedia, raise the hinge of the platen cover and press down the cover for best results.



Cutting the Top Margin of the Original and Printing [Top Margin]

You can cut the top portion of the margin to between 0 to 99 mm (0.0" to 3.9") and make a master. This feature enables you to skip the registration marks* on the original and print on the finish-sized paper without any of these marks.

A margin on the paper periphery is required even if you use "Top Margin" function.

☞ p.18

* About the Registration Mark

In the field of commercial printing, it is normal to print on paper that is larger than the finished size and then cut down to the finished size afterwards. The symbol that indicates the position to cut in this event is known as the registration mark.

Important!:

- When setting both the "Size" and "Top Margin", cut the Top Margin within the specified range and then enlarge/ reduce the original.
- Do not use "Auto Reproduction Size".
- This function cannot be used with "Multi-Up Print" and "2 Up".
- An ADF unit (option) cannot be used with "Top Margin".

1 Place an original.

Place the original face down on the Glass Platen. Align center on the top edge, and close Platen Cover.

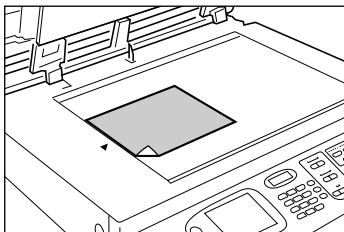

2 Touch [Functions] on the Master Making Basic Screen.

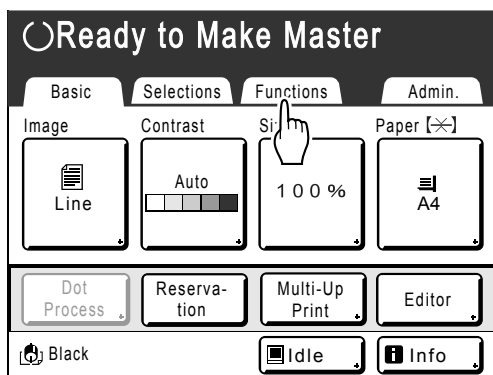

3 Touch [Top Margin].

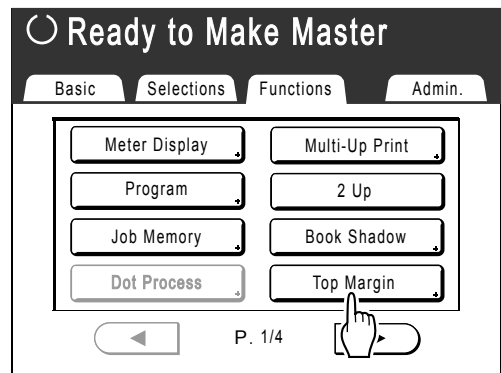

4 Touch [ON].

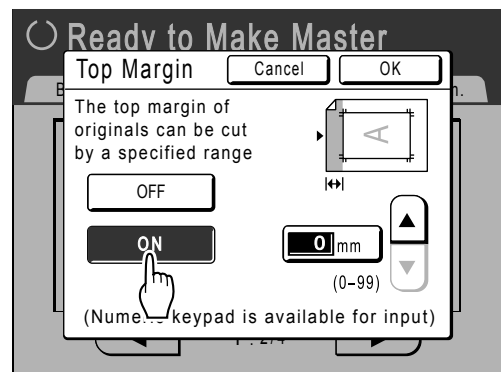

5 Touch ▲ or ▼ to specify the cut width.

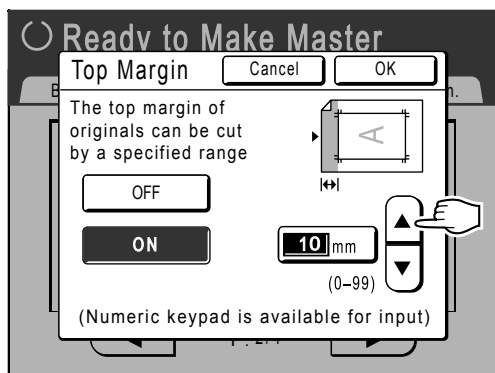

You can set from 0 to 99 mm (0.0" to 3.9").

Note:

- Print Quantity Keys can also be used to enter numbers.

6 Touch [OK].

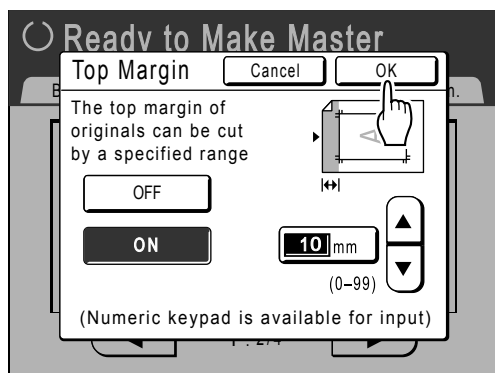

The following screen appears.

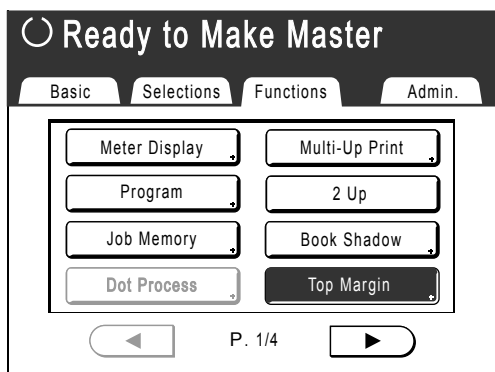

Returns to the Functions screen.
 "Top Margin" setting is updated.

Adjusting the Side Margins of the Master

[Side Margin]

If you are using the ADF unit (Option) to print multiple originals and need to move the left and right margins to make a master, use “Side Margin” for one simple operation to offset the margins for all the originals (up to 10 mm (0.4”) left/right).

Important!:

- The “Side Margin” function shifts the location of the original to the right or left. It does not reduce the size of the original.
- By using “Side Margin”, the opposite side of the side margin may be pushed out of the print area and not print. Check the margins of the original prior to setting.
- This function cannot be used with the following functions.
 - Multi-Up Print
 - 2 Up

Note:

- This function can be used to set the side margins even when the original is set on the Glass Platen.

1 Touch [Functions] on the Master Making Basic Screen.

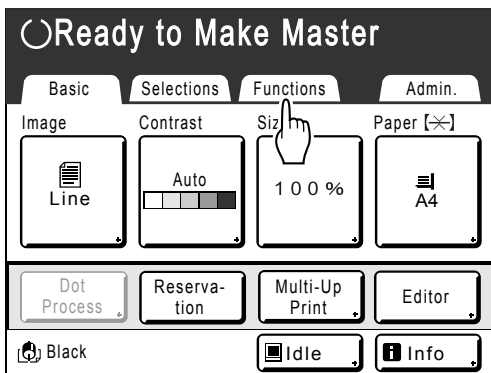

2 Touch [Side Margin].

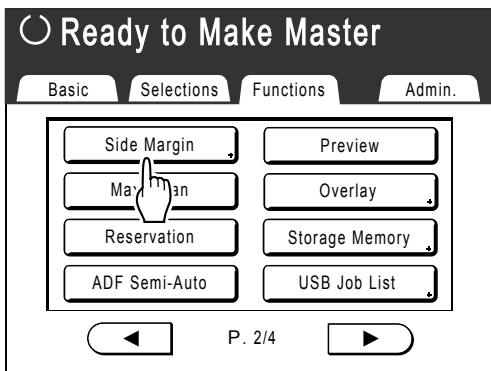

3 Touch [Left] or [Right] to adjust.

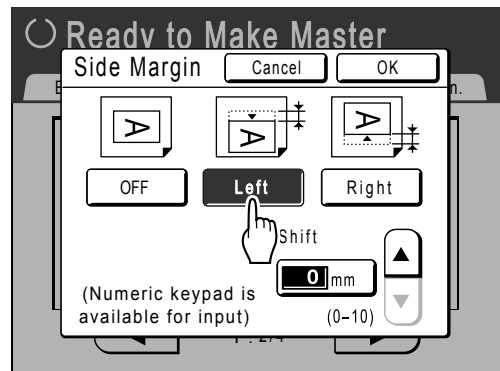

4 Touch ▲ or ▼ to specify the shift distance.

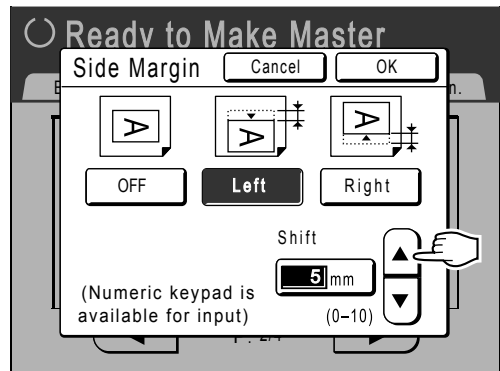

You can set from 0 to 10 mm (0.0" to 0.4").

Note:

- Print Quantity Keys can also be used to enter numbers.

5 Touch [OK].

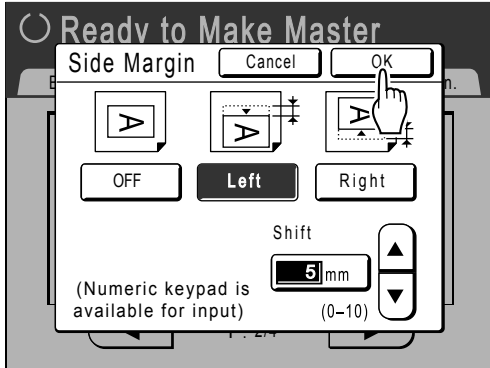

The following screen appears.

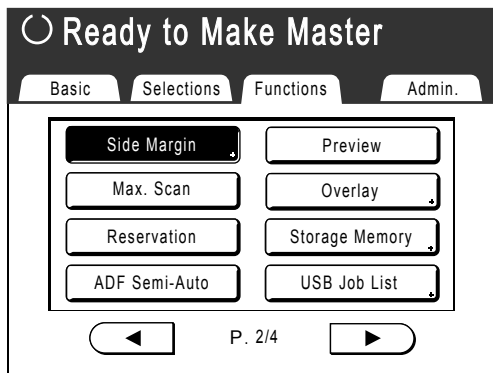

Returns to the Functions screen.
"Side Margin" setting is updated.

Checking the Print Image Prior to Making Master [Preview]

You can check what the actual master will look like by previewing an image of the scanned original or an image of data sent from a computer. This function is handy for checking the layout or final image of a Multi-Up job. The operation and display timing differ depending upon the mode.

Mode name (original type)	When set	When to display	If "Auto Processing" is ON
Printing from the Original Document	When setting functions related to Master Making (settings from Functions)	After Scanning the Original	Scans the original, then temporarily stops to display preview.
Scan Mode	When setting functions (master making functions) related to Scanning (setting from Functions)	After Scanning the Original	When in scan mode, an original is scanned and then saved, so there is no "Auto Process" operation. However, if multiple originals are placed in an ADF unit (Option), you can touch [Close] after reviewing the preview to start the scan of the next original.
Printing Original Data from a Computer	Stopping the print job prior to making a master (Semi-Auto(Print)/Auto Process OFF), after the machine has received the original data	Displays when touching [Preview]	A preview is not shown if data is sent from the printer driver with "Full Auto".
Retrieving Storage Data/ USB Flash Drive data and printing	When retrieving storage data/USB Flash Drive data (set on the Storage Mode Basic Screen).	Displays when touching [Preview]	If you touch [Preview] , it displays immediately. Touch [Close] and press the  key to make a master/print with "Auto Process".

Note:

- Preview shows an image oriented towards output after printing.
- It shows the scanned original as-is. A margin is required when actually printing. Check to make sure that the margins are sufficient.
- In "Direct Print" operation, **[Preview]** will be displayed on the Master Making Basic Screen when data is received from the computer.

 p.43

Actions Available on the Preview Screen

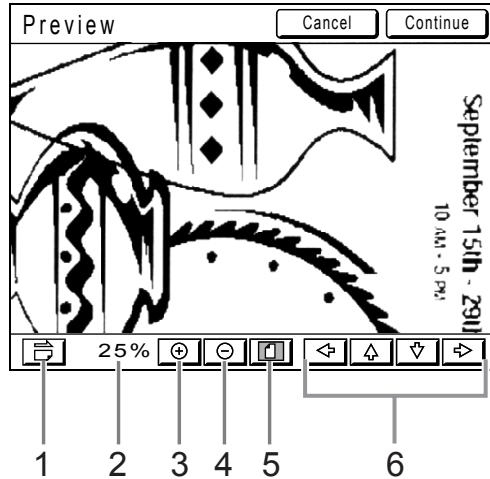

- 1) Rotate Image Button**
Allows you to rotate the displayed image 90 degrees.
- 2) Displays the size of the current display.**
- 3) Enlarge Button**
Enlarges the preview display each time it is touched.
- 4) Reduce Button**
Reduces the preview display each time it is touched.
- 5) Show All Button**
Shows the entire image.
- 6) Scroll Button**
The image in the display screen moves in the direction of the arrow.

Operation for Preview

The operational procedures for “Printing from the Original Document” are explained below.

- 1 Place an original.**
p.38
- 2 Touch [Functions] on the Master Making Basic Screen.**
- 3 Touch [Preview].**

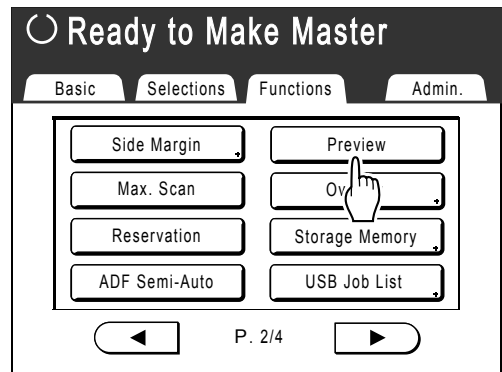
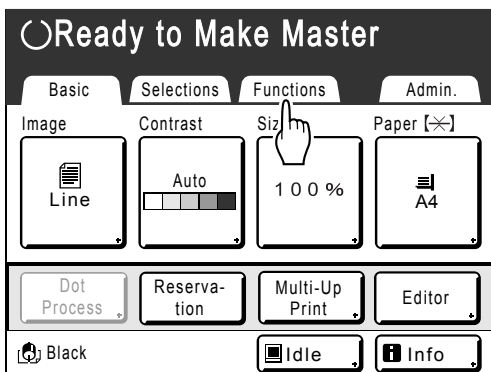

“Preview” setting is updated.

4 Make necessary settings.

You can configure print functions to apply to the new original as needed.

5 Press the key.

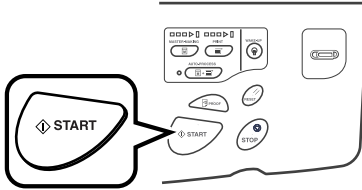

A scan of the original begins, and can be previewed on the Preview screen.

6 Check the preview image.

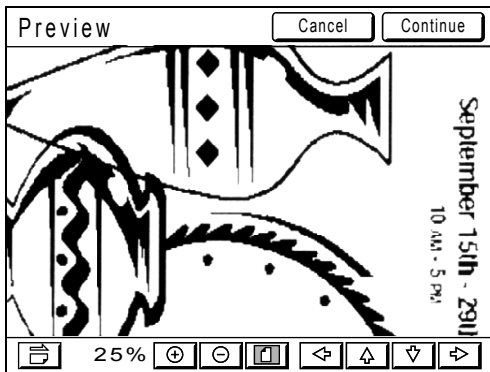

You can use various controls on this screen to check the image.

☞ p.84

7 Touch [Continue].

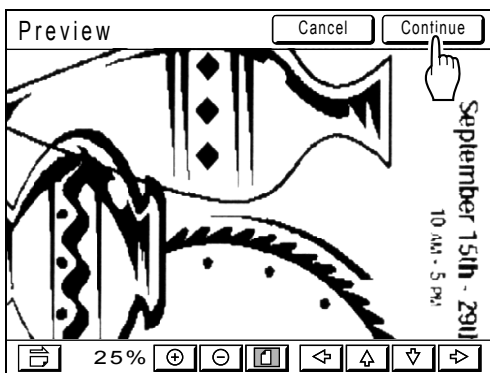

A master is created using the settings configured in step 4.

After this, follow the same operations for paper documents.

Note:

- Touching **[Cancel]** will cancel the image, returning to the Master Making Basic Screen. To continue previewing images, repeat from step 4.

Making a Master that Utilizes the Maximum Printing Area [Max. Scan]

When a master is made, automatic paper size detection and image size adjustment applies to allow appropriate print margins. This is to prevent paper jams, and to keep internal roller free of ink stains.

By selecting “Max. Scan”, maximum printing area will apply to the scanned image, regardless of the print paper size or original document size.

Be sure to check the sizes of the original document and the printing paper first.

☞ p.18

◆ Maximum printing area

EZ590: 291 mm × 425 mm (11⁷/₁₆" × 16³/₄")

EZ570: 291 mm × 413 mm (11⁷/₁₆" × 16¹/₄")

Important!:

- The 5 mm (³/₁₆") margin on the top cannot be scanned even in the “Max. Scan” setting.
- Do not use print paper smaller than the area of the image made on the master. This may cause ink stains.
- The entire surface of the Glass Platen must be clean.
By scanning the maximum size, dirt found outside the original document area will also be included in the master. This may cause the internal roller to be stained with ink.

1 Touch [Functions] on the Master Making Basic Screen.

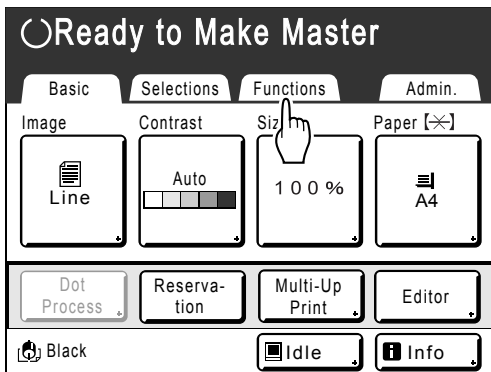

2 Touch [Max. Scan].

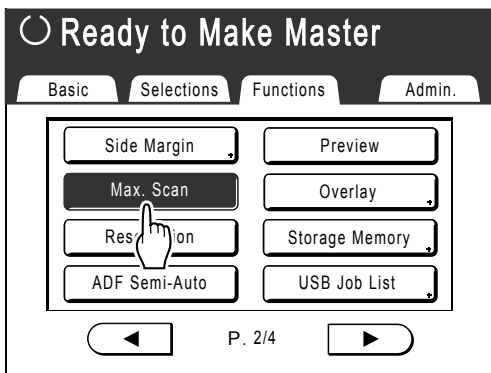

“Max. Scan” is selected.

Functions for Printing

Changing the Print Speed

[Print Speed Adjustment]

You can select the print speed from five levels; from 60 to 130 pages/minute. The print speed may be changed while printing is in progress.

Note:

- The default print speed can be set on the Admin. screen.
The factory default is level 3 (approximately 100 pages/minute).
p.163

Press the ◀ or ▶ key to change the print speed.

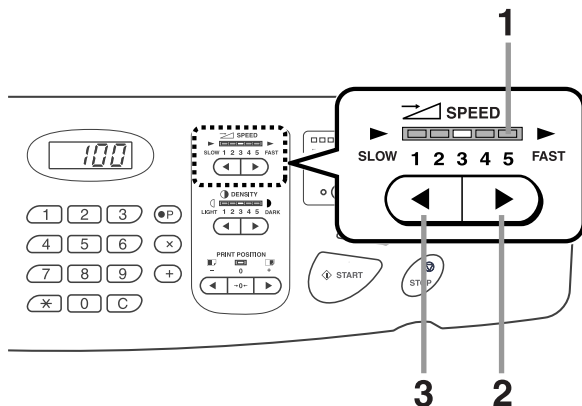

- 1) **Print Speed Adjustment Indicator**
Shows the current print speed.
- 2) **▶ Key**
Increases the print speed incrementally.
- 3) **◀ Key**
Decreases the print speed incrementally.

Indicator level and print speed

Indicator Level	1	2	3	4	5
Print Speed (pages/minute)	Approx. 60	Approx. 80	Approx. 100	Approx. 120	Approx. 130

Adjusting the Print Density

[Print Density Adjustment]

You can select the print density from five levels.
The print density may be adjusted while printing is in progress.

Important!:



- “Print Density” is not available when **[Ink Saving]** is selected.
☞ p.64

Note:

- The default print density can be set on the Admin. screen.
The factory default is set at level 3 (Standard).
☞ p.163

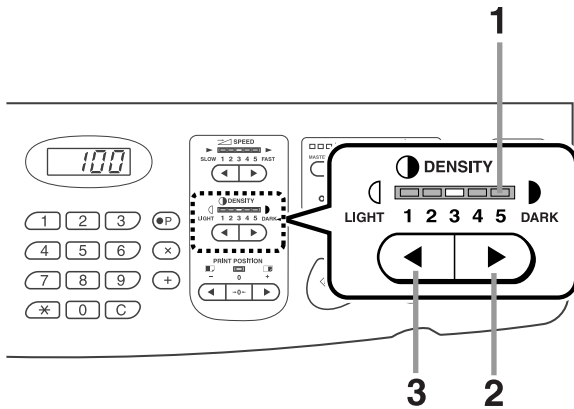
Press the  or  key to adjust the print density.



- 1) **Print Density Adjustment Indicator**
Shows the current print density.
- 2)  **Key**
Increases the print density incrementally.
- 3)  **Key**
Decreases the print density incrementally.

Adjusting the Print Position

[Print Position Adjustment]

Use the Vertical Print Position Adjustment keys to adjust the print position in the vertical direction; and use the Horizontal Print Position Adjustment Dial (located on Paper Feed Tray) to adjust it in the horizontal direction.

Adjustment range Vertical direction: $\pm 15 \text{ mm}$ ($\pm 19/32$ ") Horizontal direction: $\pm 10 \text{ mm}$ ($\pm 3/8$ ") *

The vertical positioning may be adjusted while Printing is in progress.

*For paper of widths over 297 mm ($\pm 11 11/16$ "), the adjustment range in the horizontal direction becomes smaller than $\pm 10 \text{ mm}$ ($\pm 3/8$ ").

Important!:

- After adjusting the print position, print a proof copy to check the result.
☞ p.92

Vertical (Up/Down) Adjustment

Press the ◀ or ▶ key to move up or down.

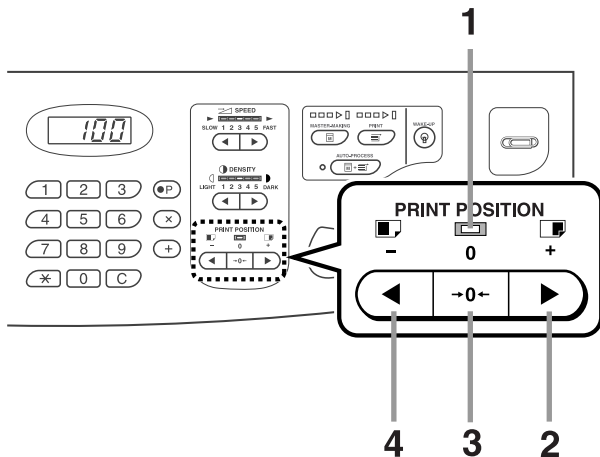

1) Center Position Indicator

Indicates when vertical positioning has not changed.

2) ▶ Key

Each press shifts the print position upward in steps of about 0.5 mm ($1/64$ ").

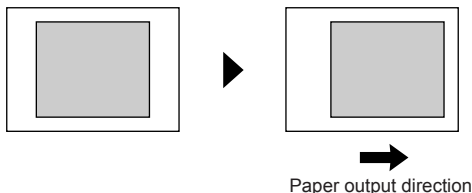

3) -0- Key

Press to return to original position.

4) ◀ Key

Each press shifts the print position downward in steps of about 0.5 mm ($1/64$ ").

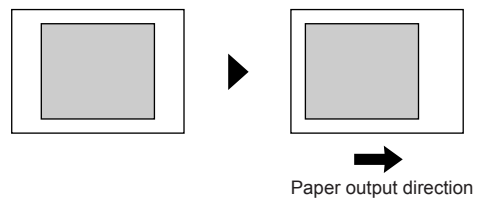

The Print Basic Screen shows current vertical adjustment.

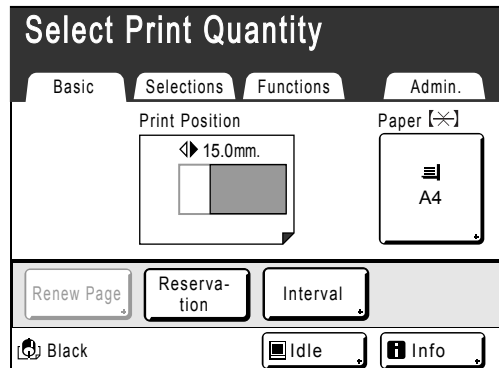

Horizontal (Left/Right) Adjustment

1 Press the Feed Tray Ascent/Descent Button to lower the Paper Feed Tray.

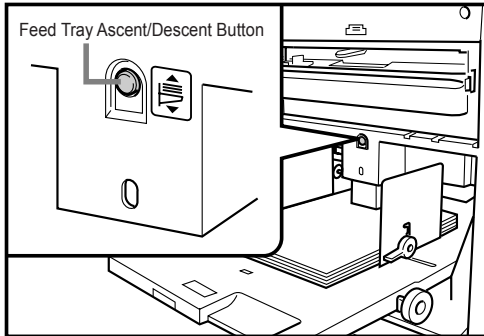

2 Turn the Horizontal Print Position Adjustment Dial to move horizontally (left or right).

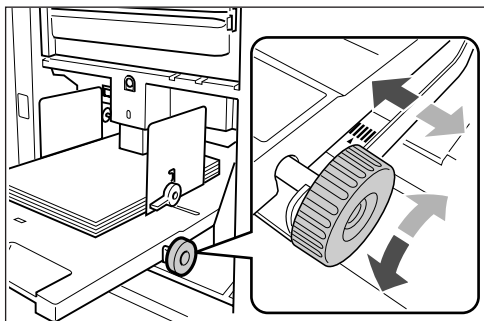

◆ Turning clockwise

Paper: moves to right
Print Position: moves to left

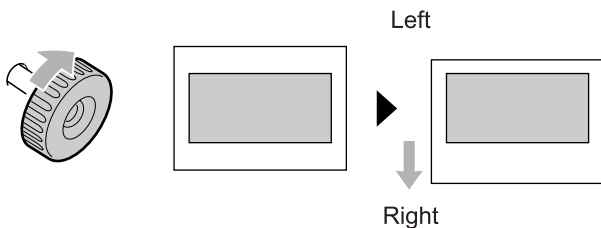

◆ Turning counter-clockwise

Paper: moves to left
Print Position: moves to right

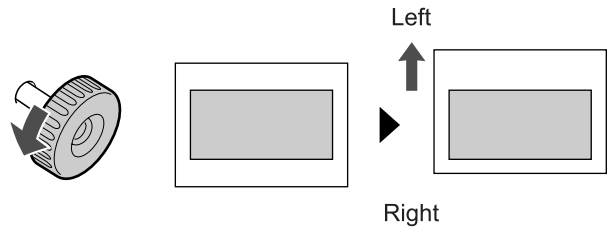

Check the amount of offset from the center by looking at the gauge beside the Paper Feed Tray. (Horizontal adjustment cannot be checked on the Display.)

▲ indicates center on the gauge. Press the  key to verify positioning by proof copy.

Important!:

- Be sure to adjust the Receiving Tray Paper Guides after moving left or right.
☞ p.35
- Be sure to re-position the Paper Feed Tray to center after printing is completed.

Printing Proof Copies [Proof]

After making adjustments to the print position or density, check the print quality in a proof copy. Proof copies are not counted towards the number of copies displayed on the Print Quantity Display.

Note:

- The machine will continue to print proof copies if the  key is held down.

Press the  key.

Print Quantity Display

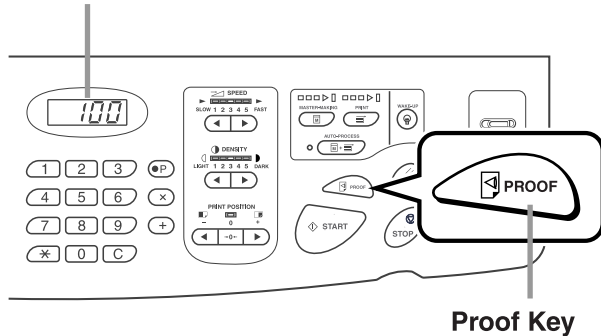

A single proof copy is printed.

Extending the drying time [Interval]

A sheet of paper is normally fed and printed with each drum (cylinder) rotation, but by extending the paper feed interval, the ink has more time to dry, which prevents ink marks on the back of the next sheet. The paper feed interval (skip rotation) can be set from 1 - 10.

1 Touch [Functions] on the Print Basic Screen.

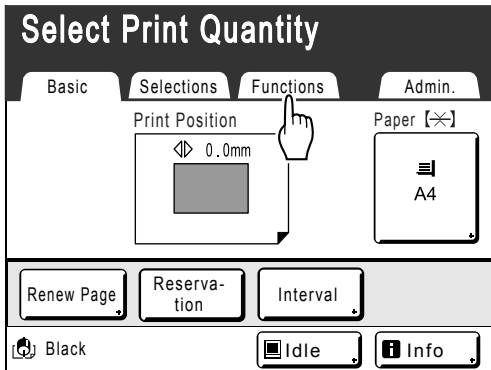

2 Touch [Interval].

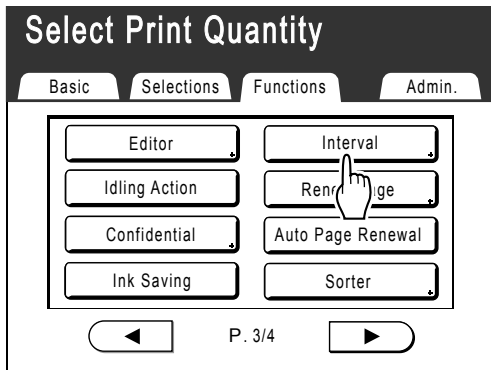

3 Touch [ON].

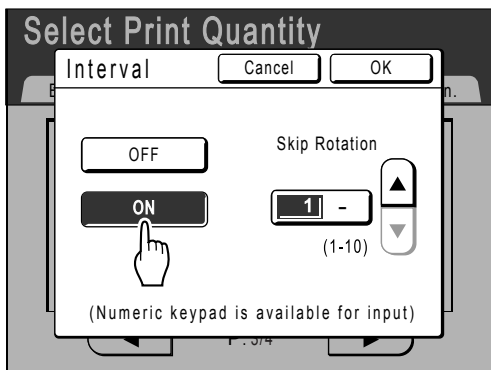

4 Touch [▲] or [▼] to set the number of Skip Rotations for the Print Drum (Cylinder).

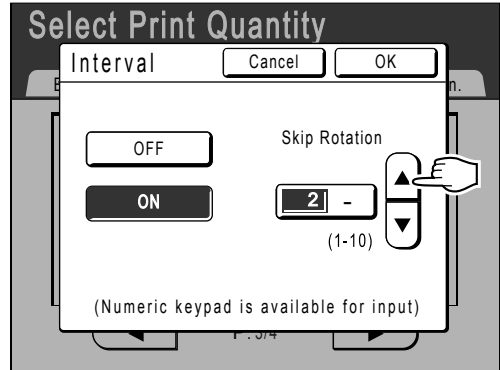

Note:

- Print Quantity Keys can also be used to enter numbers.

5 Touch [OK].

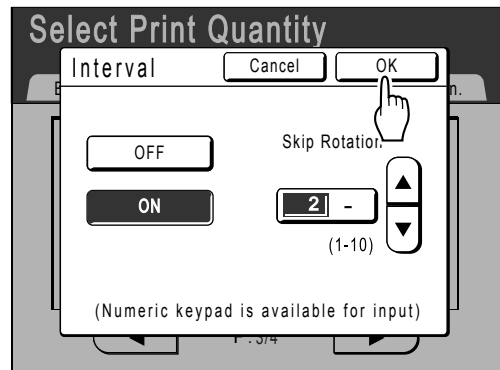

The following screen appears.

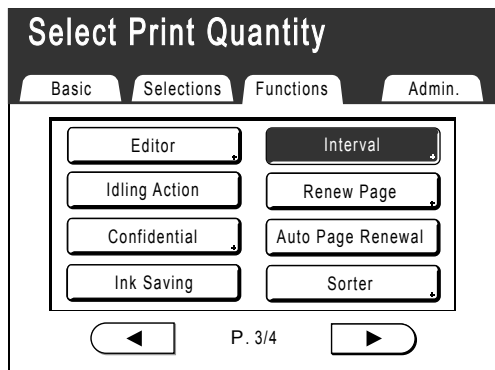

Returns to the Functions screen.
Interval setting is updated.

Paper Feed/Output Settings for Special Paper and Printing Types

[Jump Wing Control] [Special Paper Ctrl]

Paper feed and output settings can be adjusted when using special paper or uneven print finishes.

◆ Jump Wing Control

The following steps retrieve pre-configured custom settings for the Paper Jumping Wing. Use this feature to eject certain printing paper that is hard to eject with automatically adjusted normal Paper Jumping Wing setting.

Important!:

- “Jump Wing Control” feature is not available unless pre-configured.
- Only one setting can be pre-configured.
- To pre-configure or to change settings, please contact your dealer (or authorized service representative).

Note:

- The Paper Jumping Wing is a device which helps eject printed paper onto the Paper Receiving Tray. It automatically adjusts according to the position of the Paper Feed Pressure Adjustment Lever (standard or thick).

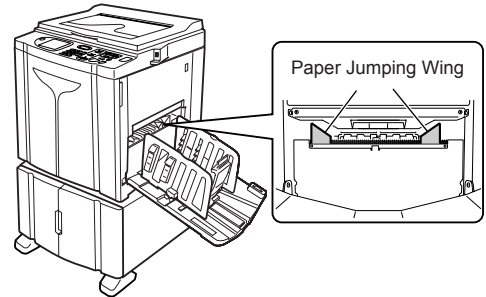

◆ Special Paper Ctrl

You can save settings for easy retrieval next time. The “Special Paper Ctrl” menu contains the following options:

Paper Feed Adj.

Adjust Paper Feed Tray position and paper-feed amount to suit special paper characteristics. For adjustment methods, please contact your dealer (or authorized service representative).

Paper Eject Adj.

Some types of original image/paper may be printed with an uneven or blurred finish due to separation fan settings. This option can be used to change separation fan and suction fan settings. For adjustment methods, please contact your dealer (or authorized service representative).

Setting the Jump Wing Control [Jump Wing Control]

1 Touch [Functions] on the Print Basic Screen.

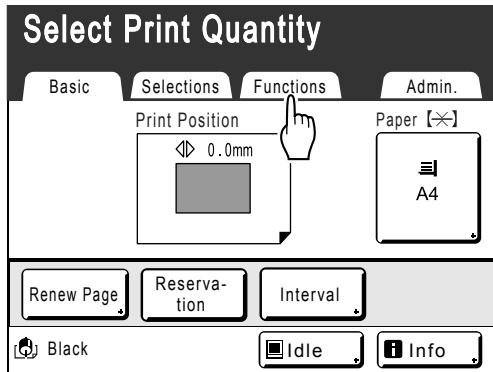

2 Touch [Jump Wing Control].

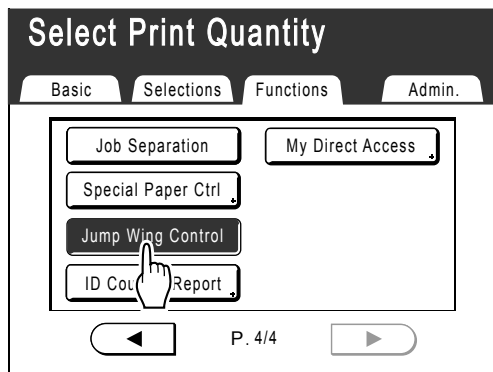

“Jump Wing Control” is selected.

Retrieving Settings from the Parameter List

1 Touch [Functions] on the Print Basic Screen.

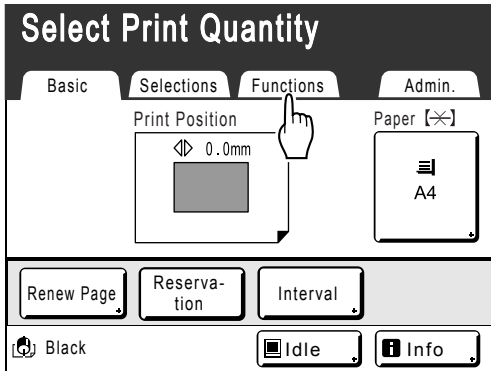

2 Touch [Special Paper Ctrl].

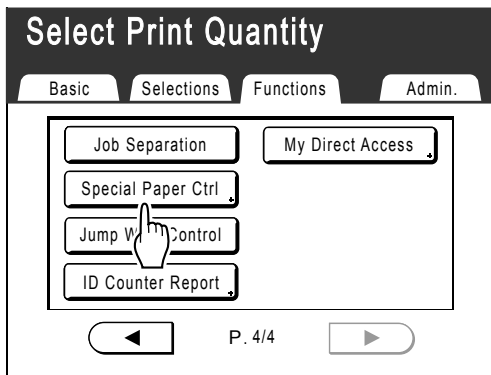

3 Touch [Entry/Call].

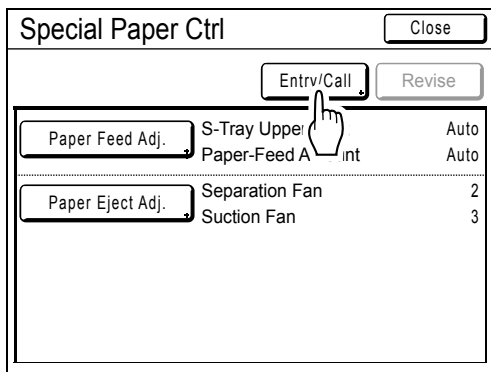

Display the Parameter List screen.

4 Touch [Retrieve].

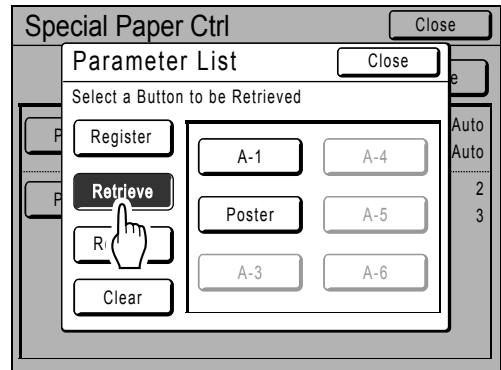

5 Touch the button to retrieve.

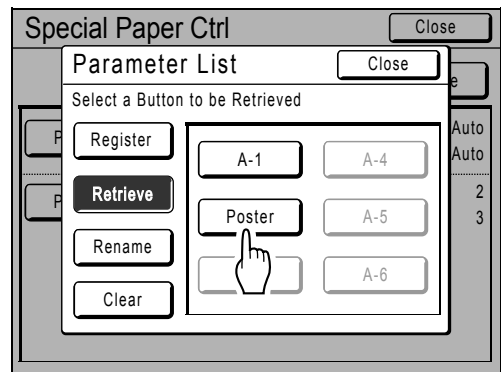

Unregistered buttons are grayed-out and are not available.

Returns to the Special Paper Ctrl screen and the desired setting is retrieved.

Confirm the settings made.

Note:

- Repeat steps 3 to 5 to retrieve other settings.

6 Touch [Close].

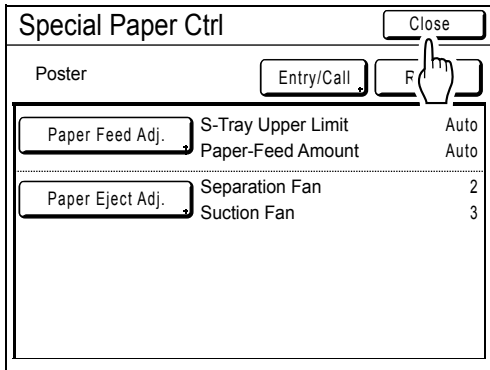

Returns to the Functions screen and the settings are updated.

After this, follow the same operations for normal printing.

Saving settings in the Parameter List

- 1 Touch [Functions] on the Print Basic Screen.

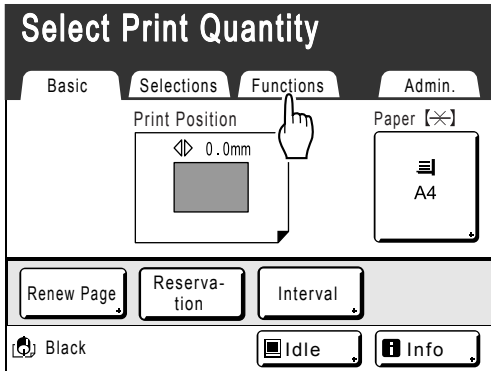

- 2 Touch [Special Paper Ctrl].

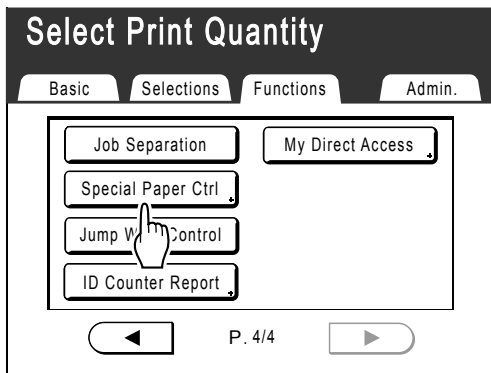

- 3 Adjust [Paper Feed Adj.] and [Paper Eject Adj.].

Note:

- For details of adjustments, see [p.95](#).

- 4 Confirm the adjustments on the Special Paper Ctrl screen.

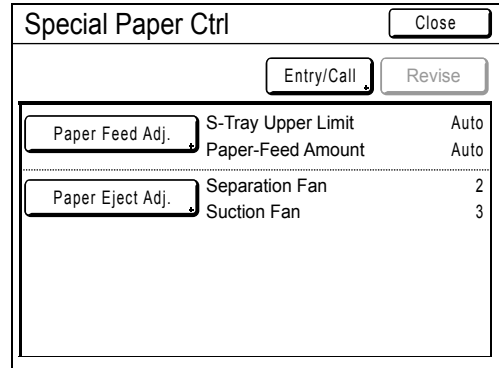

- 5 Touch [Entry/Call].

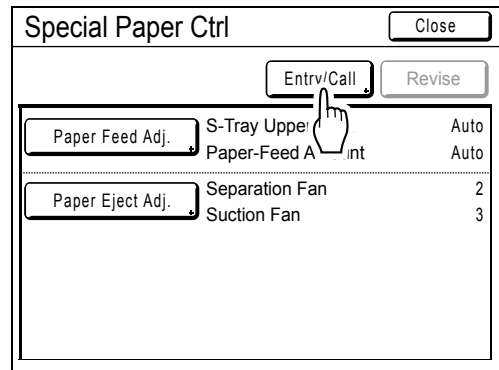

Parameter List screen is displayed.

- 6 Touch an unused button.

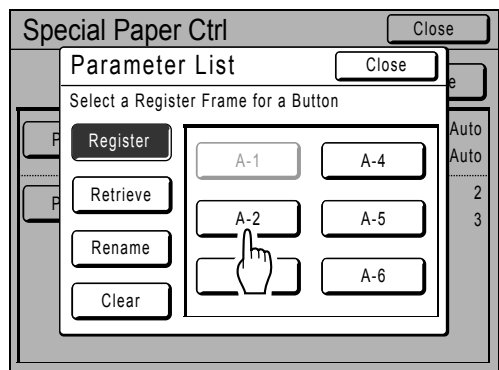

Unused buttons are displayed with a solid line. Used buttons are grayed-out and are not available.

7 Touch [OK].

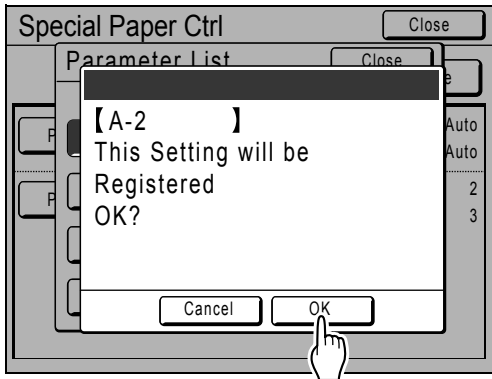

The following screen appears.

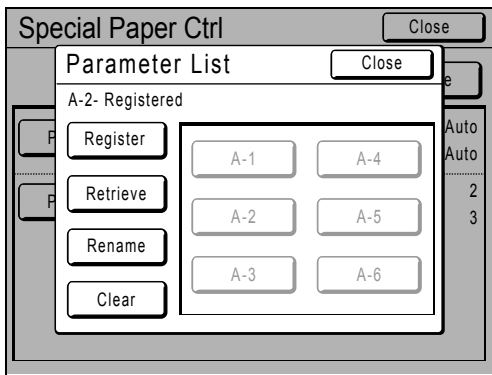

Returns to the Parameter List after the settings have been registered.
The name of each parameter can be changed for your convenience. To change parameter names, see the step 8.

Note:

- After registering the settings, touch **[Close]** on the Parameter List screen to return to the Special Paper Ctrl screen.
- Touch **[Close]** on the Special Paper Ctrl screen to return to the Functions screen. Printing will be done with the registered settings.

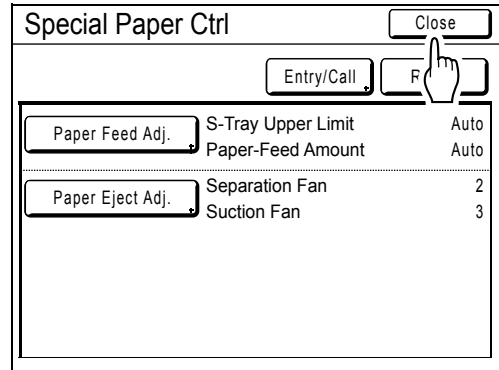

- If you do not wish to print after registering the settings, press the  key on the control panel.

8 Touch [Rename].

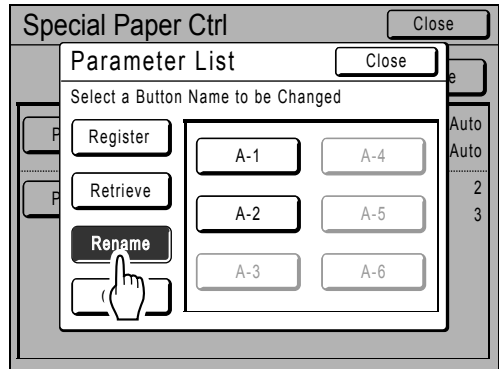

9 Touch the button to rename.

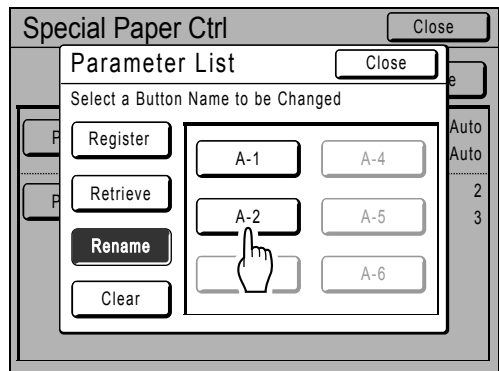

Unregistered buttons are grayed-out and are not available.

10 Touch the character buttons to enter a new name.

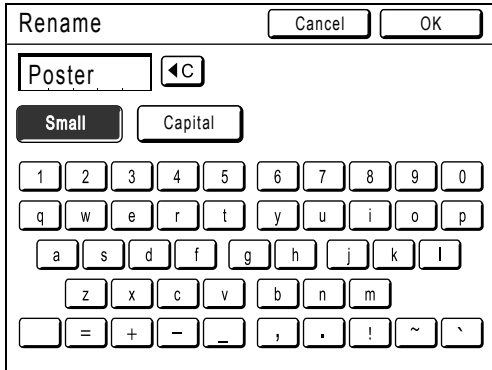

Change capitalization by selecting the **[Small]** or **[Capital]** button.

p.133

Note:

- To delete the current name, touch **⌫** button or press the **(C)** key.

11 Touch [OK] after entering all the characters.

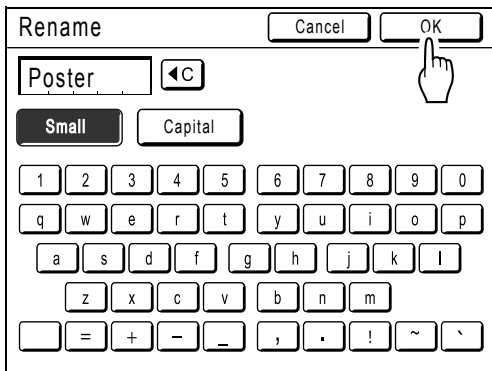

Returns to the Parameter List screen and the name is updated.

12 Touch [Close].

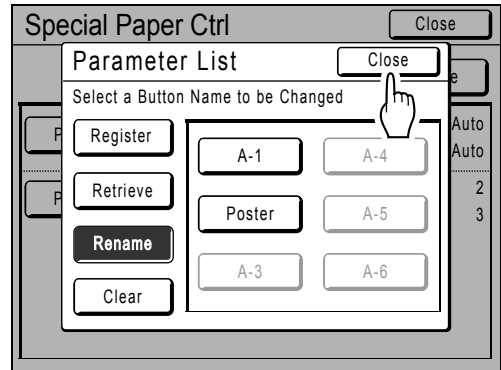

Returns to the Special Paper Ctrl screen.

Making changes to Special Paper Ctrl Setting

1 Display the Parameter List screen.

Follow steps 1 to 3 (p.97).

2 Touch [Retrieve].

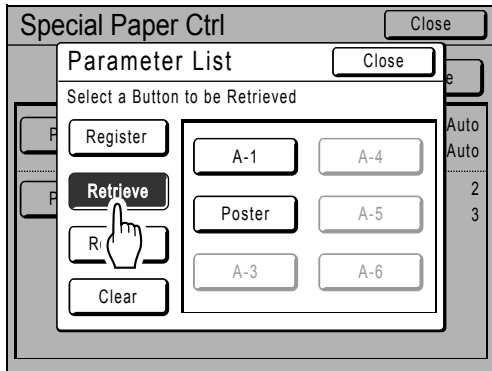

3 Touch the button to change.

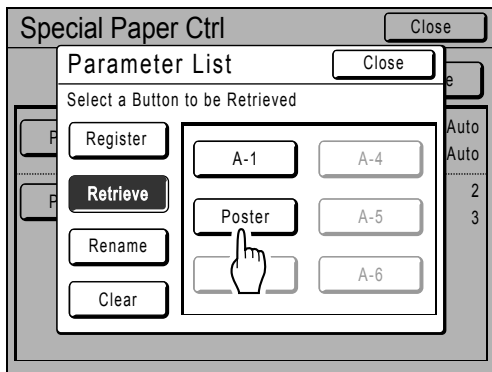

4 Change the setting parameters.

Parameters for the following can be changed: "Paper Feed Adj." and "Paper Eject Adj."

Note:

- For details of changes, see p.95.

5 Touch [Revise] on the Special Paper Ctrl screen.

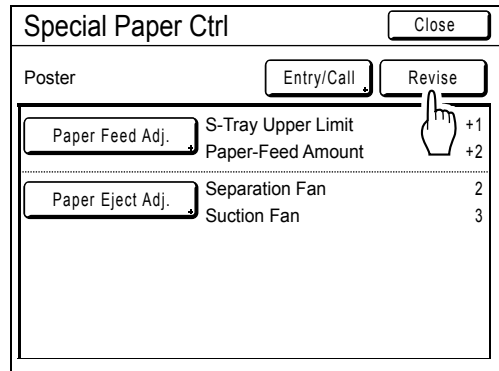

6 Touch [OK].

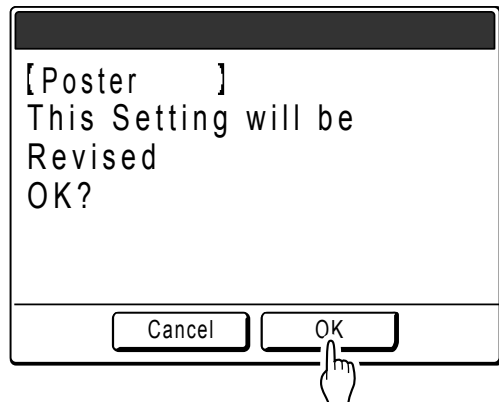

The following screen appears.

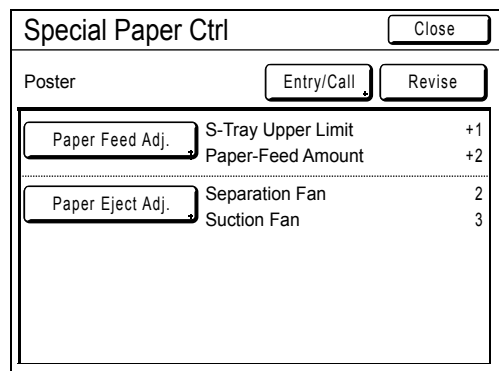

Returns to the Special Paper Ctrl screen after parameters have been revised.

Clearing Special Paper Ctrl Settings

1 Display the Parameter List screen.

Follow steps 1 to 3 (p.97).

Important!:

- First, check whether the setting can be cleared. (Retrieve the appropriate setting and follow the steps beginning with step 2.)
- Cleared settings cannot be recovered.

2 Touch [Clear].

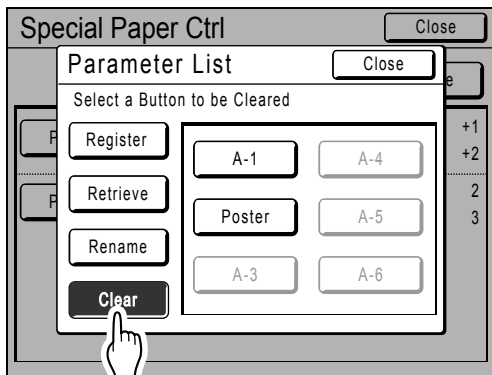

3 Touch the button to clear.

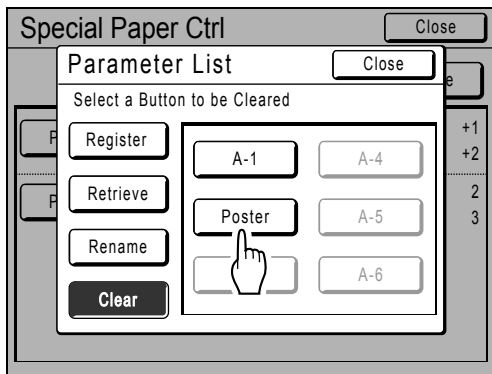

Unregistered buttons are grayed-out and are not available.

4 Touch [OK].

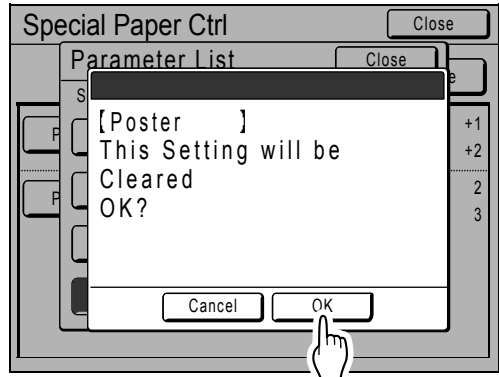

Returns to the Parameter List screen. The selected setting is cleared.

5 Touch [Close].

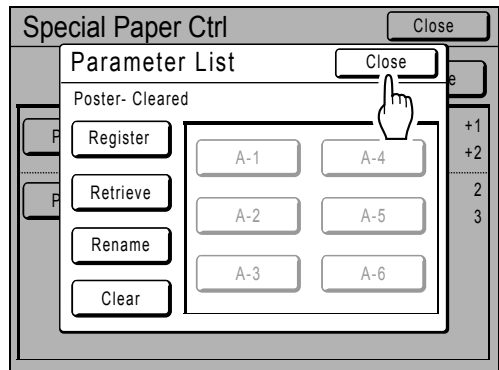

The following screen appears.

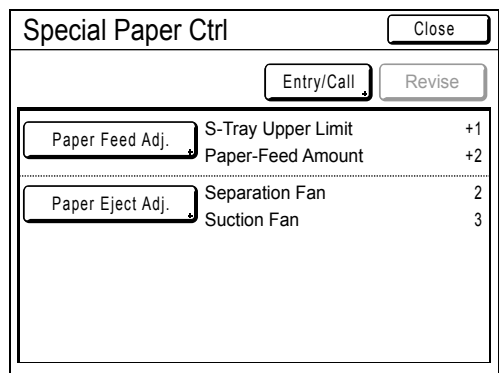

Returns to the Special Paper Ctrl screen.

Advanced Features

Setting Up User Management [User Management]

This machine is equipped with a User Management function to ensure security and enhance user management. The User Management function has 3 Management Levels. The following features are available according to level.

Feature	Management Level		
	High/Full Management	Mid/ID Print Only	Low/Admin tab Only
[ID Counter Report] for managing the number of prints/masters. p.154	Available	Available For ID print only	Not Available
[Limit] for setting the upper limit of the number of copies/masters per user set. p.115	Available	Available	Not Available
[ID Print] for printing data sent from PC. p.43	Available	Available	Not Available
[My Direct Access] for registering the frequently-accessed functions displayed in the Direct Access Area. p.158	Available	Not Available	Not Available
Saving scanned originals for [ID Print] . p.184	Available	Not Available	Not Available
Allowing only the administrator to change the [Admin.] settings. p.168	Available	Available	Available

All users must be registered to manage the machine at the High level.
Also, users must input a PIN code (or connect a registered USB Flash Drive) to use the machine.

This section explains settings for using the User Management function and how to make those settings set by the Administrator.

Management Level and access timing of user identification access

When “Management Level” is set to “High/Full Management” or “Mid/ID Print Only”, the users will be asked to identify themselves (“User identification access”) during operations. The Recognition and Identification System can be selected from either “PIN code” or “USB Flash Drive” which set by the administrator in advance.

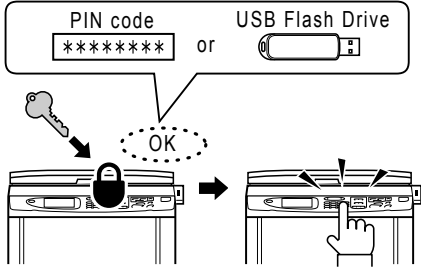
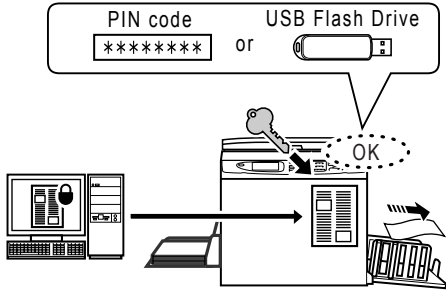
	When Operating the Machine	When Outputting the ID Print
High/Full Management	<p>User identification access is required</p> 	<p>User identification access is not required</p>
Mid/ID Print Only	<p>User identification access is not required</p>	<p>User identification access is required</p> 
Low/Admin tab only	<p>User identification access is not required</p>	<p>ID Print cannot be performed</p>

User Management Options

To activate the User Management function, the administrator must set up User Management. The setting options of User Management and details are explained below.

◆ “Recognized by” (☞p.107)

Select the Recognition and Identification System.

PIN code: When user identification access is required, input the PIN code.

Set up to 8 digits for each user in “Create User”.

USB Flash Drive: When user identification access is required, connect the registered USB Flash Drive to the USB slot. Prepare the number of USB Flash Drives for the individual users and register them with the machine.

OFF/Delete: Delete the information registered in User Management (administrator/user registration included), and return to the factory setting.

Important!:

- If the “Recognized by” setting is changed, all settings in User Management, including the administrator’s registration, will be deleted. Set “Recognized by” first, then operate the other settings.

◆ “Management Level” (☞p.109)

Select the Management Level from among 3 levels.

High/Full Management: Users require identifying themselves when operating the machine and outputting the ID Print.

Mid/ID Print Only: Users require identifying themselves when outputting the ID Print.

Low/Admin tab only: Manages the users without any use of security features. Users don’t require identifying themselves when operating the machine and cannot perform ID print. This level allows only the administrator to change the [Admin.] settings.

For details, see the table of ☞p.104.

◆ **Create User (☞ p.110)**

Register the administrator/users.
Up to 100 users (administrator included) can be registered.
Set following options when registering.

- **PIN code or USB Flash Drive**
PIN code: A PIN code can be set for user identification access.
We recommend that you prepare a list of the registered users and record the user registration numbers (ID) and PIN codes for each user.
Notify each user of the set PIN code and user registration number (ID).
USB Flash Drive: A USB Flash Drive can be set for user identification access.
We recommend that you record which USB Flash Drives you distribute to which user.
Distribute to each user a registered USB Flash Drive and a user registration number (ID).
- **Rename**
- **Group:** User groups can be set.
- **Limit:** The upper limit of the copies/masters can be set.
- **Disable:** User identification access can be enabled or disabled.

Registered settings can be changed or cleared.
In order to register users or operate other settings in User Management, the administrator must be registered in advance. The User Management functions are activated after registering the administrator.

◆ **Rename Group (☞ p.121)**

Set a group name when operating group management.
Up to 32 groups can be registered.

◆ **Reset Counter (☞ p.123)**

Clear the usage counters of all users and groups.

Operation flow of User Management

We recommend that you set up User Management in following order.

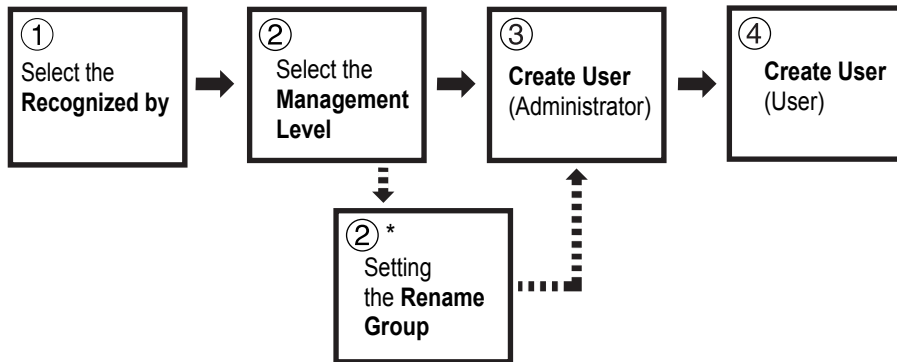

*Set when you want to count user usage by group using “ID Counter Report”. See ☞ p.154.

Selecting Recognition and Identification System

Set the Recognition and Identification System using “Recognized by” in advance when setting up User Management.

Important!:

- If “Recognized by” is changed, all settings in User Management, including the administrator’s registration, will be cleared.

1 Touch [Admin.] on the Basic Screen for each mode.

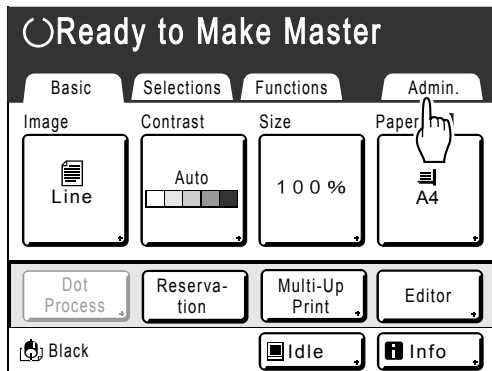

2 Touch [OK].

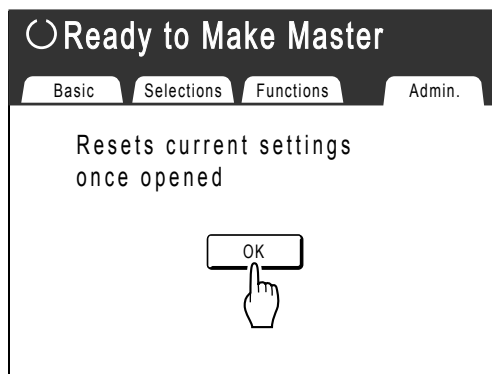

Skip to step 4 if the administrator is not registered. If the administrator is already registered, the Recognition Screen is displayed here. See step 3.

3 Identify the administrator.

◆ When “Recognized by” is set to “PIN code”

Input the administrator’s PIN code.

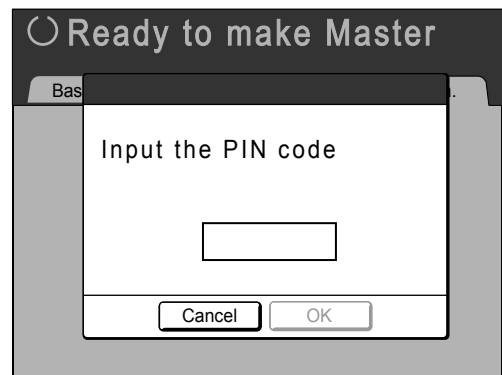

◆ When “Recognized by” is set to “USB Flash Drive”

Connect the administrator’s registered USB Flash Drive to the USB slot.

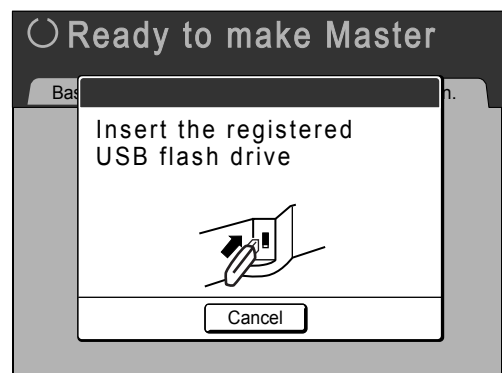

4 Touch [User Management].

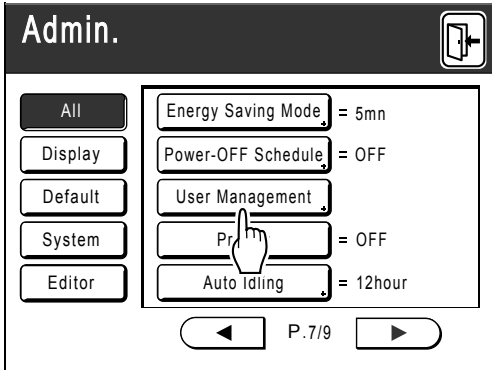

5 Touch [Recognized by].

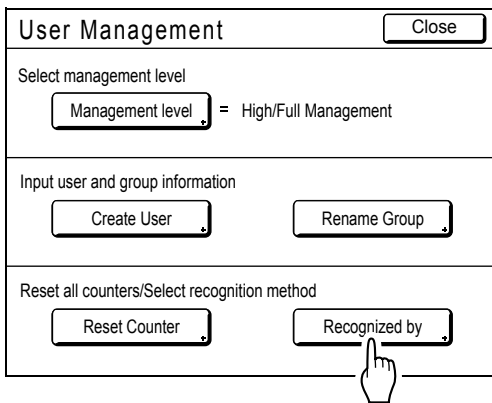

6 Touch the button to select the “Recognized by” option.

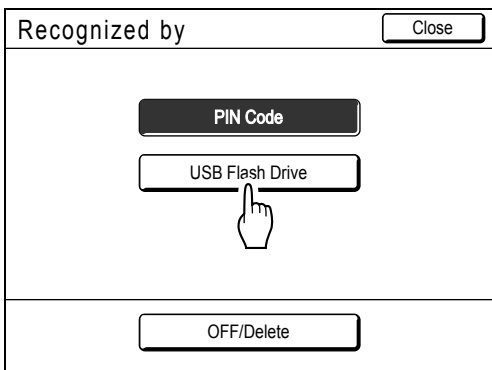

If you touch **[OFF/Delete]**, all settings set in User Management will be deleted and returned to the factory setting.

7 Touch [OK].

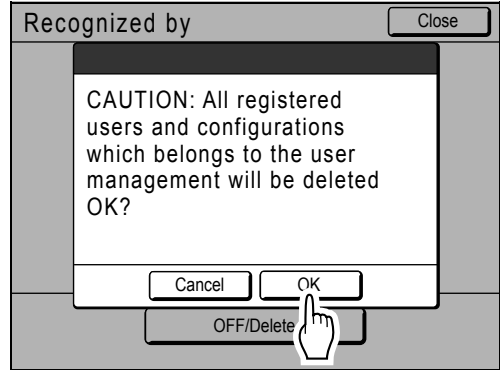

The following screen appears.

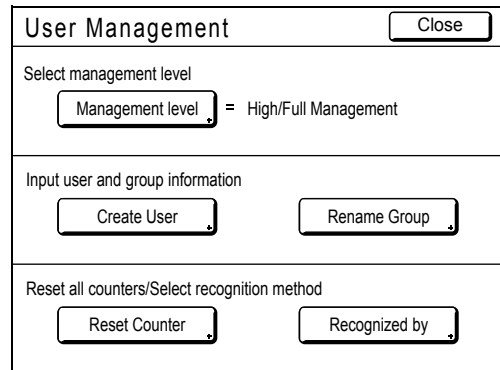

Returns to the User Management screen. “Recognized by” is updated.

Continue User Management settings. See the subsequent pages.

Setting Up the Management Level

Important!:

- Set “Recognized by” in advance.
 ☞ p.107

1 Display the User Management screen.

Follow steps 1 to 4 in “Selecting Recognition and Identification System” (☞ p.107).

2 Touch [Management Level].

User Management Close

Select management level
 Management Level = High/Full Management

Input user and group information
 Create User Rename Group

Reset all counters/Select recognition method
 Reset Counter Recognized by

3 Touch the button to select the “Management Level” option.

Management Level Cancel OK

High/Full Management

Mid/ID Print Only

Low/Admin tab only

See ☞ p.104 for details of Management Level options.

4 Touch [OK].

Management Level Cancel OK

High/Full Management

Mid/ID Print Only

Low/Admin tab only

The following screen appears.

User Management Close

Select management level
 Management level = Mid/ID Print Only

Input user and group information
 Create User Rename Group

Reset all counters/Select recognition method
 Reset Counter Recognized by

Returns to the User Management screen.

“Management Level” is updated.

You can continue registering users and renaming groups if needed.

To close the User Management setting, touch **[Close]** on the User Management screen to return to the Admin. screen.

Registering Administrator/Users

In order to activate the User Management function, the administrator must be registered. Up to 100 users can be registered (administrator included).

Note:

- The user registration number (ID) is required when operating “ID print” from the printer driver.

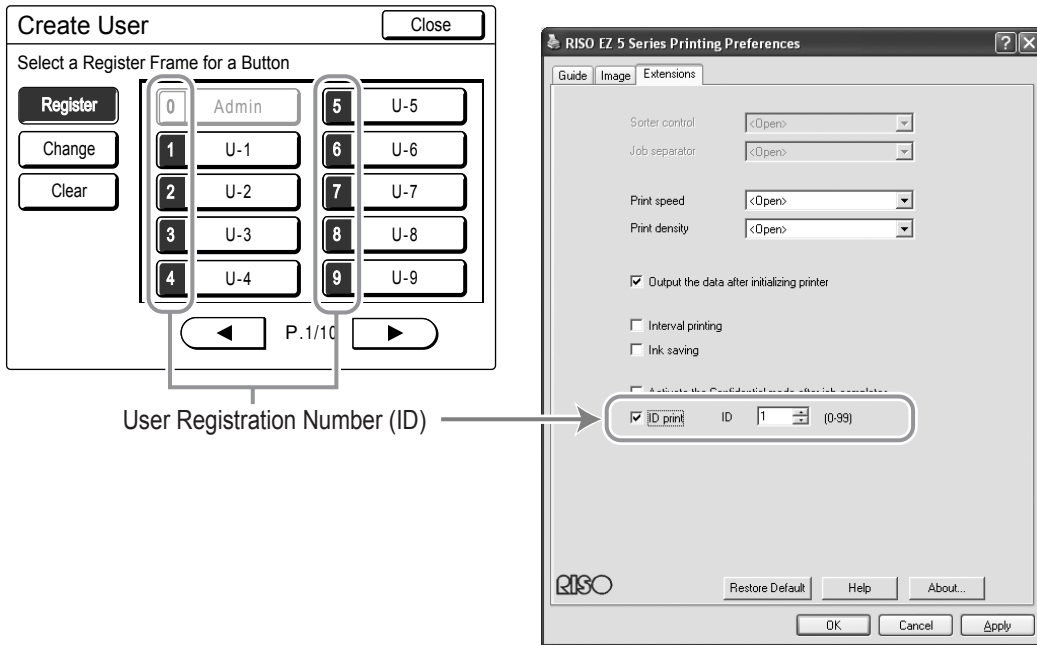

◆ Basic operation for registering administrator/users

1 Display the User Management screen.

Follow steps 1 to 4 in “Selecting Recognition and Identification System” (p.107)

Important!:

- Set “Recognized by” in advance.
- If you set the group to assign, we recommend that you set “Rename Group” first. (p.121)

2 Touch [Create User].

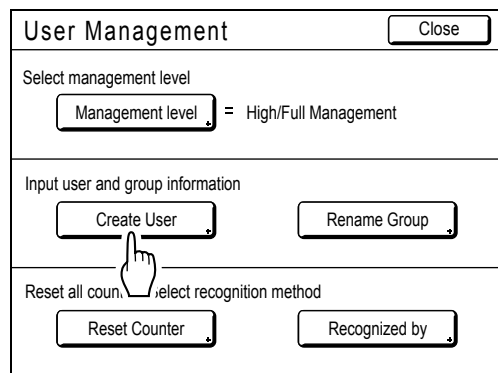

3 Touch an unused button.

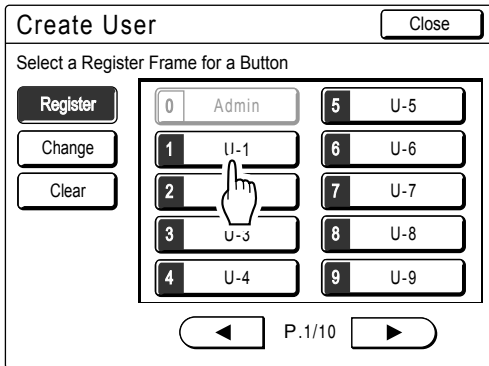

Unused buttons are displayed with a solid line. Used buttons are grayed-out and are not available. (Another user has been registered.)

Important!:

- Be sure to register the administrator first.
- If the administrator is not registered, buttons are not available except “0 Admin”.
- The “0” button is only available to the administrator. Even if you rename this button, it will be treated as the administrator.

4 Input the PIN code or connect the USB Flash Drive.

◆ When “Recognized by” is set to “PIN code”

Input the PIN code using the Print Quantity Keys.

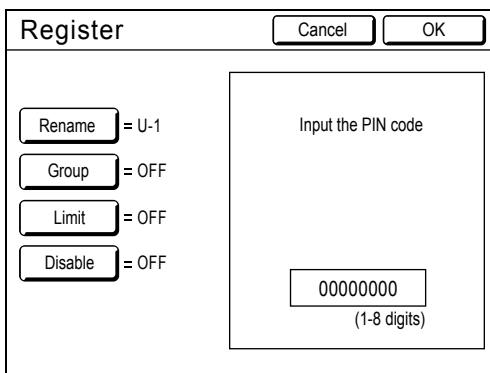

Up to 8 digits can be input.
Press the **C** key to clear the PIN code.

◆ When “Recognized by” is set to “USB Flash Drive”

Connect the registered USB Flash Drive to the USB slot.

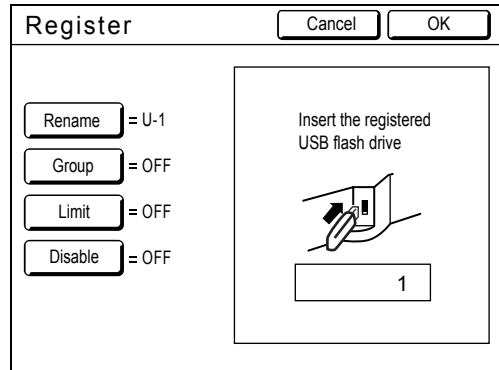

The number that identifies the registered USB Flash Drive is displayed.

Note:

- If you register multiple USB Flash Drives, we recommend that you ready them to be distinguished later (for example, put a user name on the USB Flash Drive).
- If you input the assigned PIN code (“Recognized by”: PIN code) or connect the USB Flash Drive that you already registered (“Recognized by”: USB Flash Drive), the following message is displayed when touching [OK].

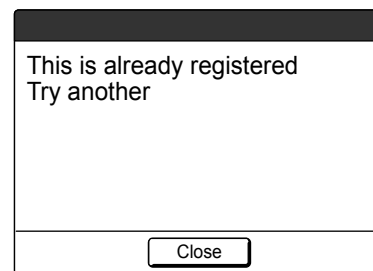

Touch **[Close]** and input the unassigned PIN code or connect the unregistered USB Flash Drive.

5 Set various settings.

Set the following settings if needed.

- Rename (☞ p.113)
- Group (☞ p.114)
- Limit (☞ p.115)
- Disable (☞ p.116)

6 Touch [OK].

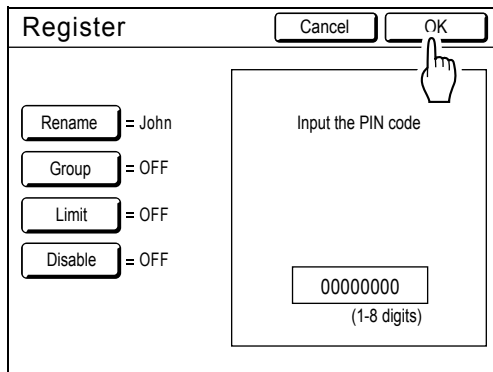

The following screen appears.

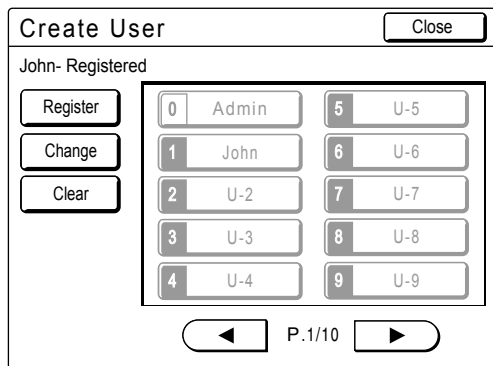

Returns to the Create User screen.
The administrator or the user is registered.
To register multiple users, touch **[Register]** and repeat steps 3 to 6.

7 Touch [Close].

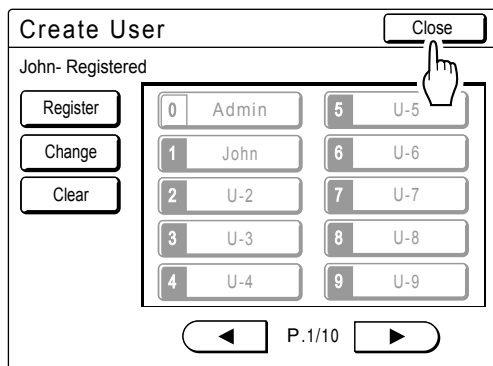

Returns to the User Management screen.
You can continue registering users and renaming groups if needed.

To close the User Management setting, touch **[Close]** on the User Management screen to return to the Admin. screen.

◆ Enter the User Name

1 Touch [Rename] on the Register screen.

Register Cancel OK

Rename = U-1

= OFF

Limit = OFF

Disable = OFF

Input the PIN code

00000000
(1-8 digits)

2 Touch the character buttons to enter a new name.

Rename Cancel OK

U-1 ◀C

Small Capital

1 2 3 4 5 6 7 8 9 0

q w e r t y u i o p

a s d f g h j k l

z x c v b n m

⏪ = + - _ , . ! ~ \

Change capitalization by selecting the **[Small]** or **[Capital]** button.

☞ p.133

Note:

- To clear the current name, touch ◀C button or press the C key.

3 Touch [OK].

Rename Cancel OK

User01 ◀C

Small Capital

1 2 3 4 5 6 7 8 9 0

q w e r t y u i o p

a s d f g h j k l

z x c v b n m

⏪ = + - _ , . ! ~ \

Returns to the Register screen.
The user name is renamed.

◆ Setting the Group to assign

By setting up a group, user usage can be counted by group.
☞ p.154

1 Touch [Group] on the Register screen.

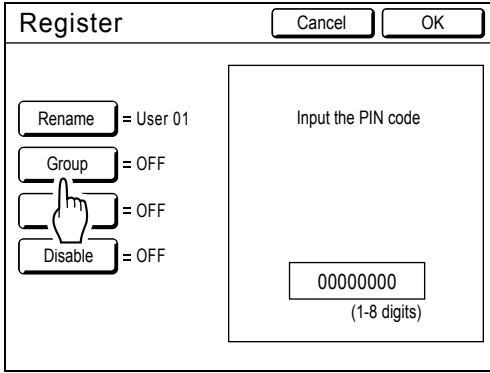

2 Touch the Group button to set.

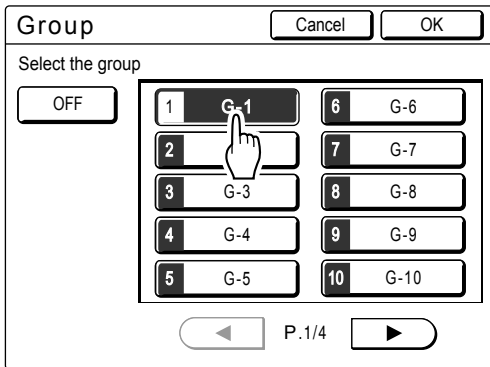

Note:

- If you are not setting up a group, touch **[OFF]**.
- The group button can be renamed. See ☞ p.121

3 Touch [OK].

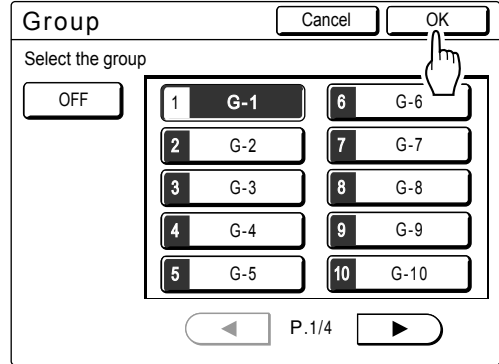

Returns to the Register screen.
The user is assigned to the group that you set.

◆ Setting the Upper Limit of the User's Usage

Set the upper limit of the number of copies/masters.

Up to 99,999,999 can be set.

The present copy count and master count can also be cleared.

1 Touch [Limit] on the Register screen.

Register

Cancel OK

Rename = User 01

Group = G-1

Limit = OFF

P = OFF

Input the PIN code

00000000
(1-8 digits)

2 Touch the limit input box and enter the upper limit number using the Print Quantity Keys.

Limit

Cancel OK

User 01 [G-1]

Limit C/C

Present C/C

Limit M/C

Present M/C

C/C: Copy Count

M/C: Master Count

Note:

- To clear the number, press the **C** key.
- “Present C/C” and “Present M/C” show the current amount of copies and masters that the user used.
- To clear the “Present C/C” and “Present M/C”, touch each **◀C** button.

3 Touch [OK].

Limit

Cancel OK

User 01 [G-1]

Limit C/C

Present C/C

Limit M/C

Present M/C

Returns to the Register screen.

“Limit” is updated.

◆ Disabling User identification access

Touch **[Disable]** on the Register screen to turn it “ON”.

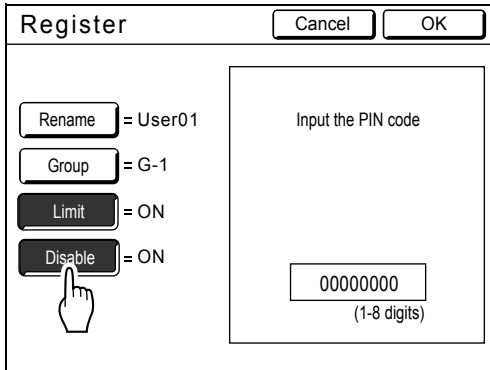

User identification access is disabled and the user cannot use the machine.

Note:

- To inactivate “Disable”, touch **[Disable]** to turn it “OFF”.
- On the Register screen for the administrator, a **[Disable]** button is not available.

Changing Administrator/User Registration

1 Display the User Management screen.

Follow steps 1 to 4 in “Selecting Recognition and Identification System” (p.107)

2 Touch [Create User].

3 Touch [Change].

4 Touch the User Button to change.

Registered buttons are displayed with a solid line. Unregistered buttons are grayed-out and are not available.

5 Change various settings.

Follow steps 4 to 5 in “Basic operation for registering administrator/users” (p.110).

6 Touch [OK].

The following screen appears.

Returns to the Create User screen.
Registered setting is updated.

7 Touch [Close].

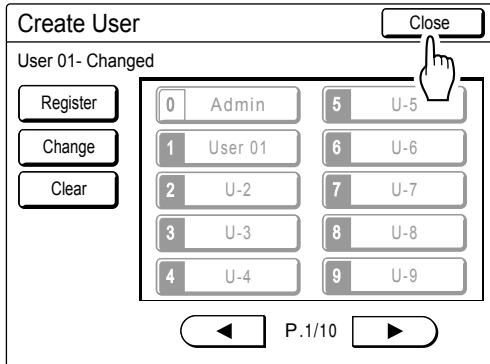

Returns to the User Management screen.

To close the User Management setting, touch **[Close]** on the User Management screen to return to the Admin. screen.

Clearing User Registration

1 Display the User Management screen.

Follow steps 1 to 4 in “Selecting Recognition and Identification System” (p.107)

2 Touch [Create User].

The 'User Management' screen has a 'Close' button in the top right. It contains three sections: 'Select management level' with a 'Management level' dropdown set to 'High/Full Management'; 'Input user and group information' with 'Create User' and 'Rename Group' buttons; and 'Reset all count, select recognition method' with 'Reset Counter' and 'Recognized by' buttons. A hand icon is shown touching the 'Create User' button.

3 Touch [Clear].

The 'Create User' screen has a 'Close' button in the top right. It features a 'Select a Button to be Cleared' section with three buttons: 'Register', 'Change', and 'Clear'. The 'Clear' button is highlighted with a hand icon. To the right is a grid of 10 buttons labeled 0 through 9 with user names: 0 Admin, 1 User 01, 2 U-2, 3 U-3, 4 U-4, 5 U-5, 6 U-6, 7 U-7, 8 U-8, 9 U-9. A hand icon is shown touching the 'Clear' button. At the bottom, there are navigation arrows and 'P.1/10'.

4 Touch the User Button to clear.

This screen is identical to the previous one, but the 'Clear' button is now grayed out. The '1 User 01' button in the grid is highlighted with a hand icon, indicating it is the selected user to be cleared.

Registered buttons are displayed with a solid line. Unregistered buttons and “0 Admin” button are grayed-out and are not available.

Important!:

- Once the user registration is cleared, it cannot be recovered.

5 Touch [OK].

A confirmation dialog box is shown over the 'Create User' screen. The dialog text reads: '1 :User 01 [1 :G-1] This user will be deleted OK?'. It has 'Cancel' and 'OK' buttons at the bottom. A hand icon is shown touching the 'OK' button.

The following screen appears.

The 'Create User' screen now shows 'U-1 - Cleared' at the top. The 'Clear' button is now active (has a solid border). The '1 User 01' button in the grid is now grayed out. The other buttons in the grid remain active. Navigation arrows and 'P.1/10' are at the bottom.

Returns to the Create User screen.
The setting of the selected user is cleared.

6 Touch [Close].

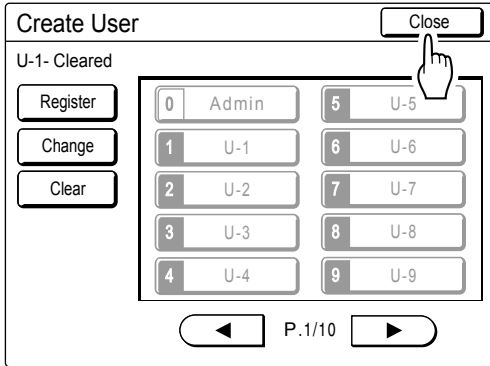

Returns to the User Management screen.

To close the User Management setting, touch **[Close]** on the User Management screen to return to the Admin. screen.

Renaming Groups

1 Display the User Management screen.

Follow steps 1 to 4 in “Selecting Recognition and Identification System” (p.107)

2 Touch [Rename Group].

The screenshot shows the 'User Management' screen with a 'Close' button in the top right. Under 'Select management level', there is a dropdown menu showing 'Management level = High/Full Management'. Under 'Input user and group information', there are two buttons: 'Create User' and 'Rename Group'. A hand icon is pointing to the 'Rename Group' button. Under 'Reset all counters/Select recognition method', there are two buttons: 'Reset Counter' and 'Recognized by'.

3 Touch the Group button to rename.

The screenshot shows the 'Rename Group' screen with a 'Close' button in the top right. The title is 'Rename Group'. Below the title is the instruction 'Select a Button Name to be Changed'. There is a grid of 10 buttons labeled '1 G-1' through '10 G-10'. A hand icon is pointing to the '2 G-2' button. At the bottom, there are navigation arrows and the text 'P. 1/4'.

4 Touch the character buttons to enter a new name.

The screenshot shows the 'Rename' dialog box with 'Cancel' and 'OK' buttons in the top right. The text field contains 'G-1' and a backspace button. Below the text field are two buttons: 'Small' (selected) and 'Capital'. Below these are several rows of character buttons: numbers 1-0, lowercase letters q-p, lowercase letters a-l, lowercase letters z-m, and symbols =, +, -, _, , , * , !, ~, `.

Change capitalization by selecting the **[Small]** or **[Capital]** button.

p.133

Note:

- You can enter up to 10 characters.

5 Touch [OK].

The screenshot shows the 'Rename' dialog box with 'Cancel' and 'OK' buttons in the top right. The text field contains 'Group 01' and a backspace button. Below the text field are two buttons: 'Small' (selected) and 'Capital'. Below these are several rows of character buttons: numbers 1-0, lowercase letters q-p, lowercase letters a-l, lowercase letters z-m, and symbols =, +, -, _, , , * , !, ~, `.

Returns to the Rename Group screen.
The group name is renamed.

6 Touch [Close].

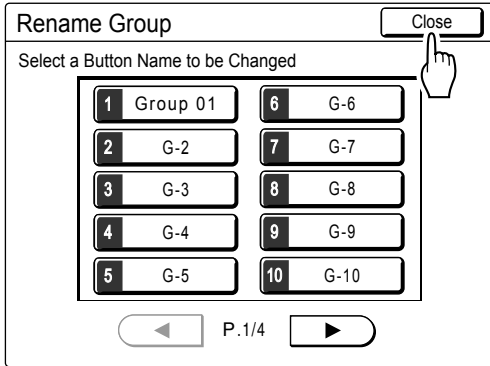

The following screen appears.

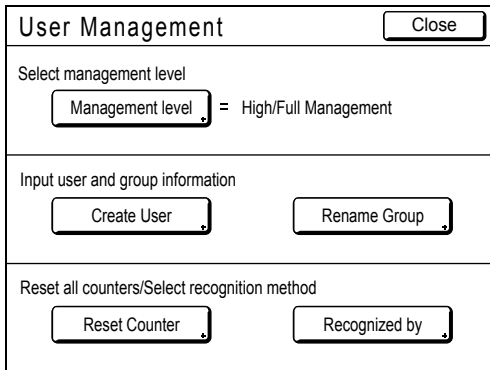

Returns to the User Management screen.

To close the User Management setting, touch **[Close]** on the User Management screen to return to the Admin. screen.

Clearing All User Counters

All user counters can be cleared in a single procedure.

Important!:

- After the counter is cleared, it cannot be recovered.

1 Display the User Management screen.

Follow steps 1 to 4 in “Selecting Recognition and Identification System” (p.107)

2 Touch [Reset Counter].

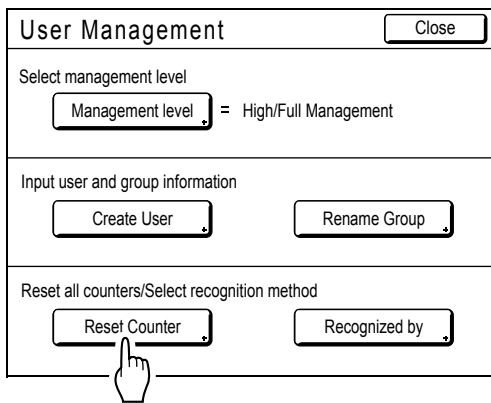

3 Touch [OK].

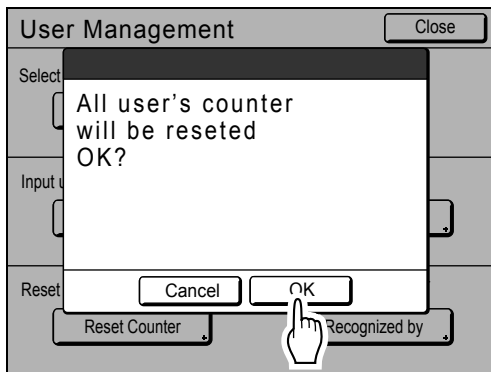

The following screen appears.

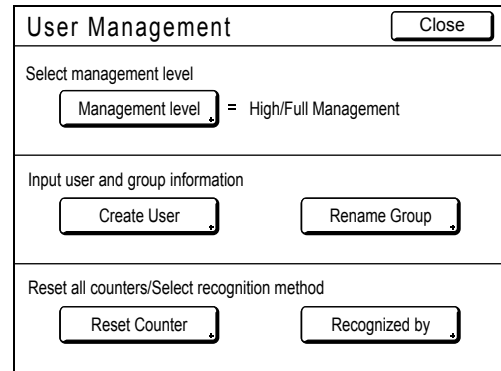

Returns to the User Management screen.
All user counters are cleared.

To close the User Management setting, touch **[Close]** on the User Management screen to return to the Admin. screen.

Protecting Confidential Documents

[Confidential]

Master left on the Print Drum (Cylinder) is capable of printing even after the print job is completed. By using the “Confidential” feature, the master on the Print Drum (Cylinder) is discarded, thus preventing unauthorized reproduction of confidential documents such as academic tests or customer lists.

Note:

- You can set the machine to remind users to use the “Confidential” feature every time it is used.
p.178

1 Make sure printing is completed.

Confirm that everything is printed.

2 Touch [Functions] on the Print Basic Screen.

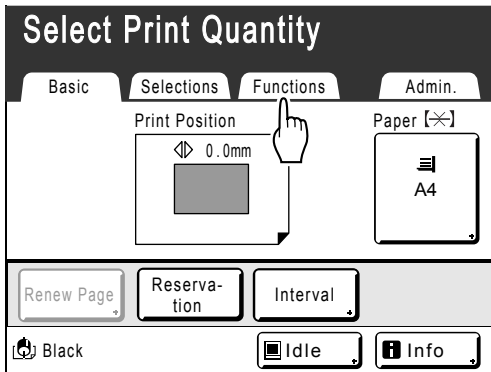

3 Touch [Confidential].

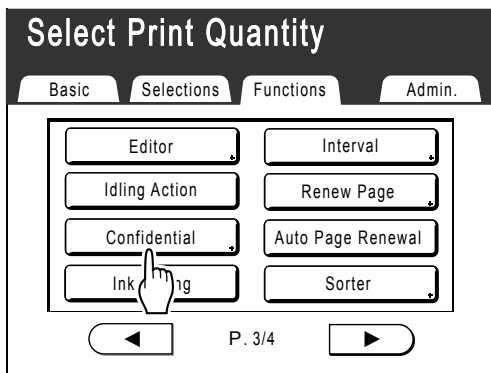

4 Touch [OK].

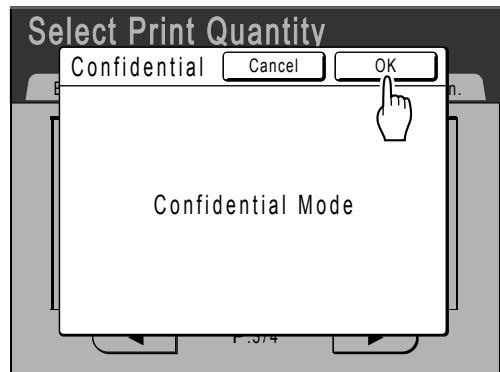

The following screen appears.

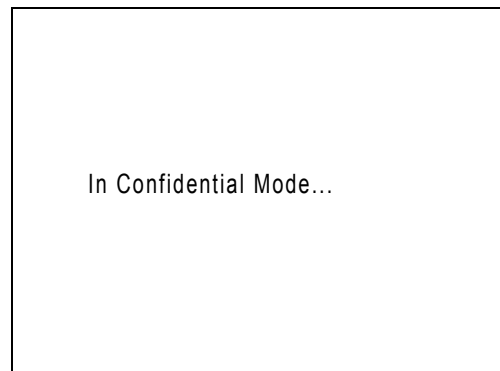

The current master is discarded, and a new master is set on the Print Drum (Cylinder).

Note:

- When “Confidential” is performed, the discarded master may no longer be reproduced, and “Renew Page”, “Auto Page Renewal” features are disabled.

Automatic Sorting Into Groups [Program]

“Program” feature saves you from repeatedly having to enter how many copies to print, by assigning the number of copies per sets in advance. Operation stops after printing each set of copies.

Store a “Program” setting for easy retrieval later.

Sample usage for this feature; in a school setting, the number of copies (sheets) per class (set) can be pre-assigned, then the number of grades (groups) in the entire school.

“Program” consists of two types: “Single” and “Multiple”.

Important!:

- After printing with “Program”, press the  key to deactivate “Program”.
- “Program” is not available when “Auto Page Renewal” is selected.

◆ Single Page Mode

From a single original document, print into multiple groups of sets.

A maximum of 50 groups can be created, each having up to 99 sets. Each set can be up to 9999 copies.

The machine can be configured to specify how many copies (sheets) per set, then how many sets are to be created for each group.

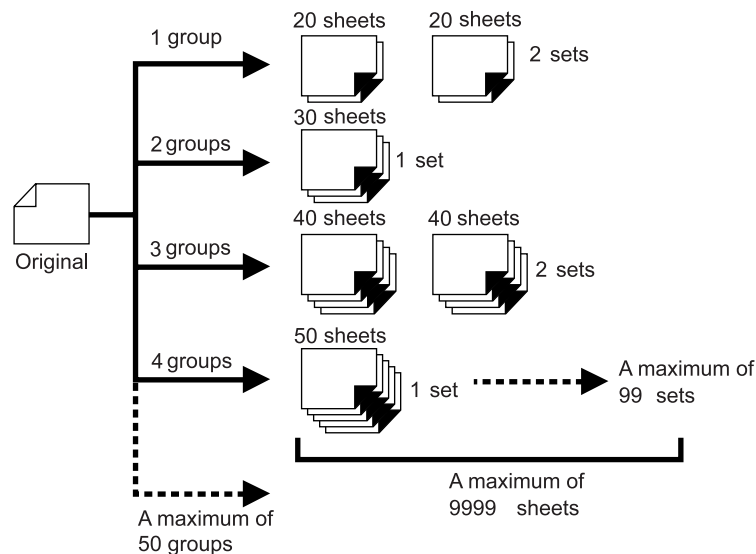

Note:

- If you are printing multiple originals with “Single Page” program, place multiple originals (up to 50) in the ADF unit (option), and as long as “Auto Process” is “ON”, the set program can be repeated and all the originals are divided into groups to print the various number of copies specified.

◆ Multi-Page Mode

For multiple originals, a different number of copies are printed for each original. From a single original, up to 9999 copies can be made. Each original can reproduce a pre-assigned number of sheets (up to 20 originals).

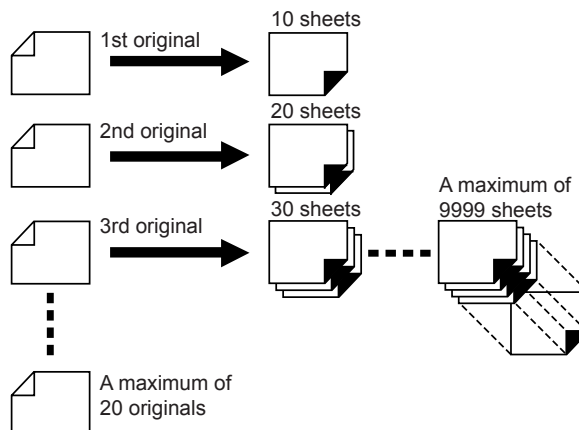

◆ How to Program Print

There are two ways to print in sets using “Program” printing feature.

- Program, then print (without saving the settings) [p.127](#)
- Retrieve a saved program, then print (when program is registered) [p.129](#)

Choose from the following actions on the Print Basic Screen. Touch a button to proceed.

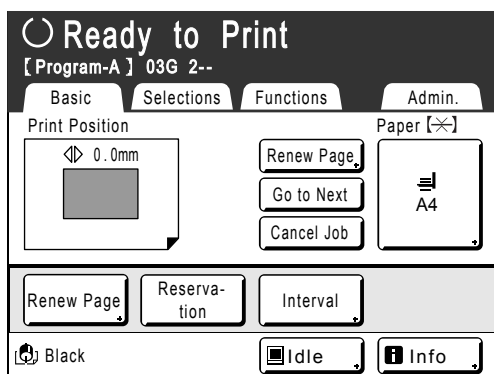

[Renew Page]: Creates a master from the last Master-Making data. [p.147](#)

[Next Page] or [Go to Next]: Stops current print job, skips to the next original, set or group.

[Cancel Job]: Cancels execution of the Program.

Note:

- The Job Separator (option) is useful for Programed Printing. The Job Separator releases a piece of tape after each set or original document, thereby automatically separating sets or groups. It eliminates the need to manually remove a stack of sheets or insert a marker between sets. Remember to activate “Job Separation” in the Functions screen when printing with the Job Separator. You must remove each stack from the Paper Receiving Tray, or insert a marker during the pause if not using the Job Separator.

Setting Up for Programed Printing

The steps below applies to both Single Page Mode Program (single original) and Multi-Page Mode Program (multiple originals).

Both the Touch Screen and Print Quantity Keys (and related keys) may be used for this operation.

1 Press the **OP** key.

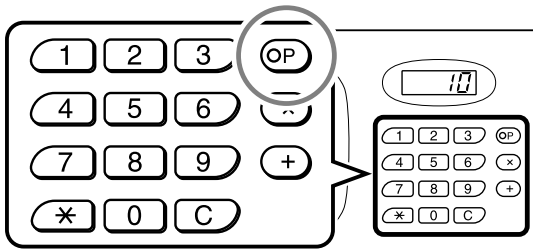

Note:

- Press the **(x)** key and skip to step 3 of the “Single Page Mode”. Press the **(+)** key and skip to step 3 of the “Multi-Page Mode”.
- Alternatively, from the Master Making Basic Screen, touch **[Functions]** then **[Program]** to display the Program Type screen.

2 Touch **[Single]** or **[Multiple]**.

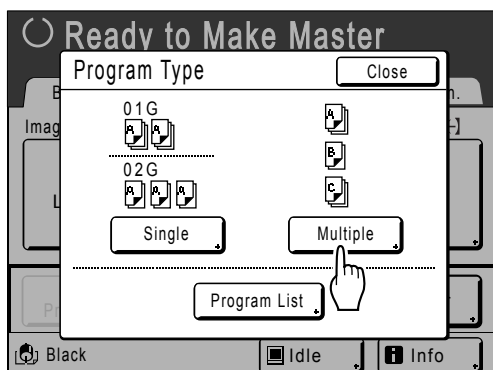
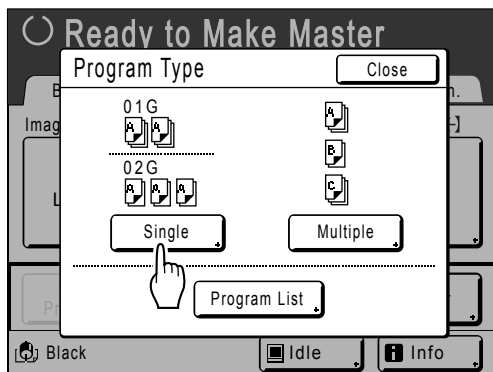

3 Enter the numbers using the Print Quantity Keys.

◆ For Single Page Mode

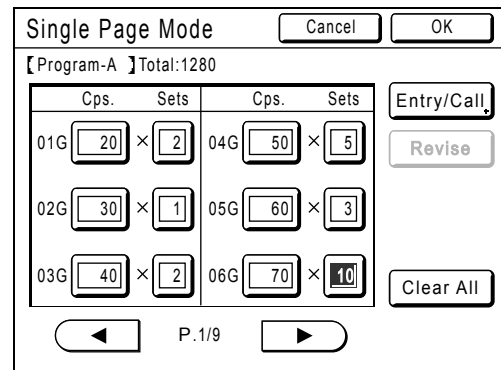

- 1) Enter the number of copies using the Print Quantity Keys.
- 2) Press the **(x)** key or the **(*)** key.
- 3) Enter the number of sets (in the group) using the Print Quantity Keys.
- 4) Press the **(+)** key or the **(*)** key.

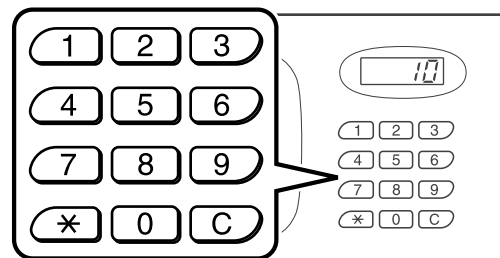

To program more than one group, repeat steps 1) to 4).

Note:

- To cancel or change a number, press the **(C)** key and enter again.
- To clear all (number of copies and number of sets), touch **[Clear All]**.
- The total number of all copies to be printed is shown on the top of the screen.

Important!:

- To save the current Programed Printing setting, touch **[Entry/Call]**.
Once **[OK]** is touched, the setting cannot be saved. See “Saving Programs” (p.130) for further information.

◆ **For Multi-Page Mode**

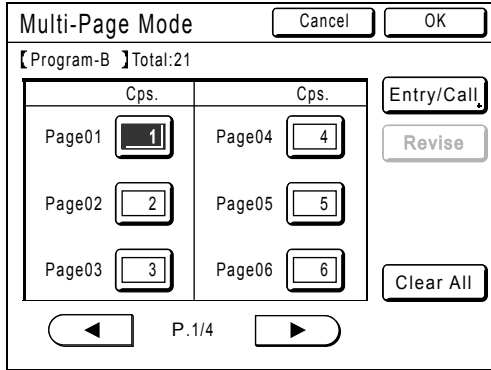

- 1) Enter the number of copies using the Print Quantity Keys.
- 2) Press the **[+]** key or the **[*]** key.
- 3) Repeat steps 1 and 2 above to enter the number of copies for each original.

Note:

- To cancel or change a number, press the **[C]** key and enter again.
- To clear all (number of copies and number of sets), touch **[Clear All]**.
- The total number of all copies to be printed is shown on the top of the screen.

Important!:

- To save the current Programed Printing setting, touch **[Entry/Call]**.
Once **[OK]** is touched, the setting cannot be saved.
See “Saving Programs” (p.130) for further information.

4 Touch [OK].

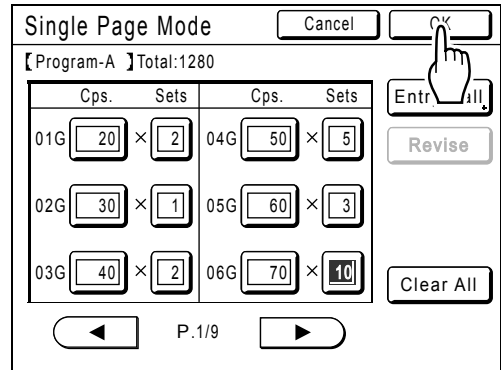

The following screen appears.

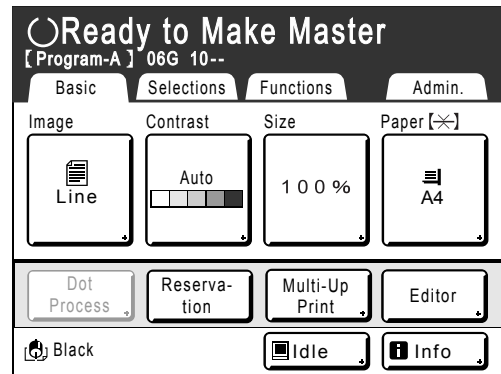

Returns to the original screen. Ready to print in accordance with the program.

Note:

- Alternatively, after entering number of copies or sets, press the **[START]** key to start printing without touching **[OK]**.

Retrieving a Program

Retrieve a stored program and modify its settings.

1 Press the **OP** key.

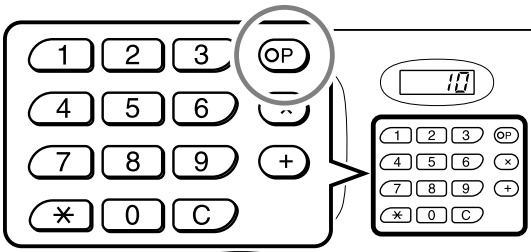

Note:

- Alternatively, from the Master Making Basic Screen, touch **[Functions]** then **[Program]** to display the Program Type screen.

2 Touch **[Program List]**.

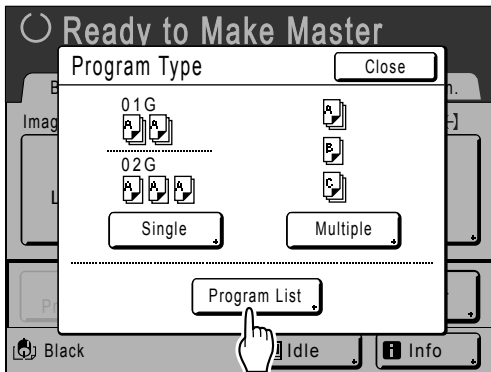

3 Touch a button to select a Program to retrieve.

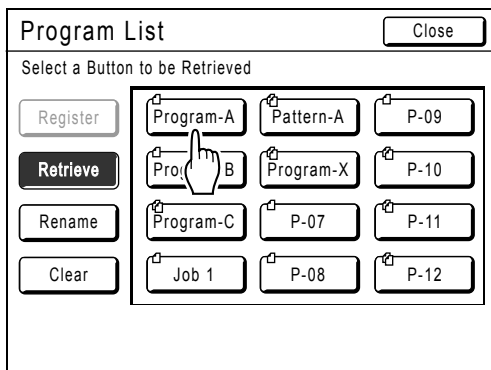

4 Touch **[OK]**.

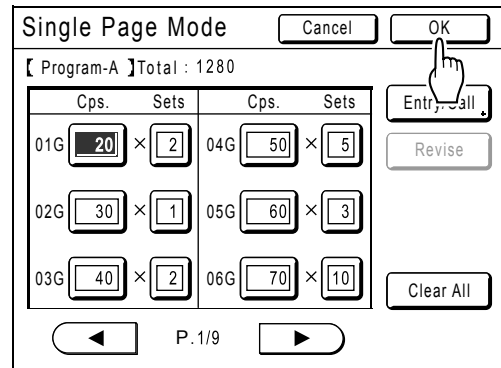

The following screen appears.

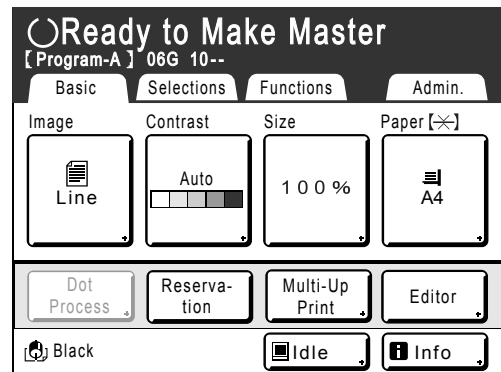

Returns to the original screen. Ready to print using the retrieved program.

Note:

- To cancel the program printing, press the **OP** key (or touch **[Functions]**–**[Program]**) and then touch **[Cancel Job]** on the next screen displayed. Canceling program printing by pressing the **RESET** key will reset other settings.

Saving Programs

Store frequently-used Program settings for later retrieval and printing. A total of 12 settings (Single or Multiple Mode) can be stored.

1 Create and enter a Programed Printing settings.

Follow steps 1 to 3 in “Setting Up for Programed Printing” (p.127).

2 Touch [Entry/Call] on the Program screen.

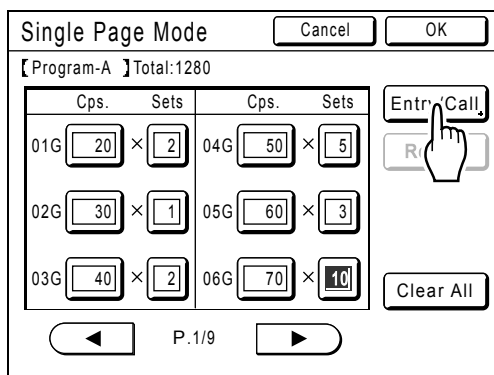

3 Touch an unused button.

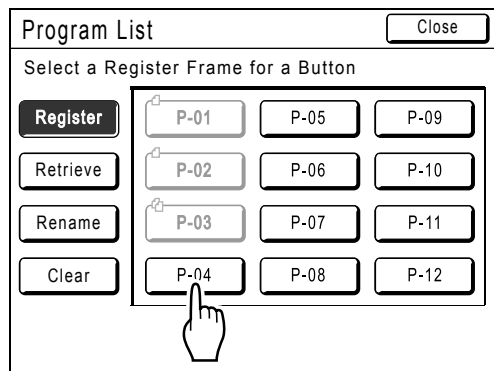

Unused buttons are displayed with a solid line. Used buttons are grayed-out and are not available.

4 Touch [OK].



The following screen appears.

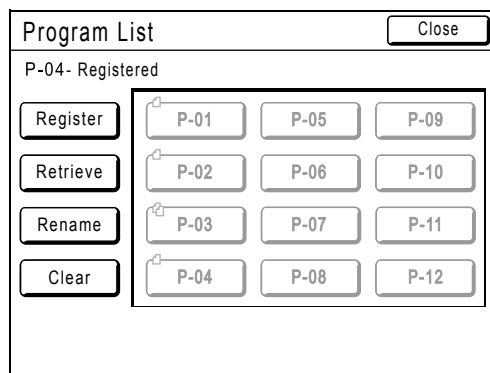

Returns to the Program List screen. The Program is stored.

Each Program can be named for your convenience. See step 3 in “Renaming a Program” (p.132).

Note:

- After saving the Program, touch **[Close]** on the Program List screen to return to the Program screen.
Touch **[OK]** on the Program screen to print from a saved Program.

Single Page Mode Cancel OK

【P-04 】Total:1280

Cps.	Sets	Cps.	Sets
01G <input type="text" value="20"/> × <input type="text" value="2"/>		04G <input type="text" value="50"/> × <input type="text" value="5"/>	
02G <input type="text" value="30"/> × <input type="text" value="1"/>		05G <input type="text" value="60"/> × <input type="text" value="3"/>	
03G <input type="text" value="40"/> × <input type="text" value="2"/>		06G <input type="text" value="70"/> × <input type="text" value="10"/>	

Enter /ll Revise Clear All

◀ P.1/9 ▶

Renaming a Program

Program names can be changed to better describe their usage or purpose.

1 Touch [Program] on the Functions screen.

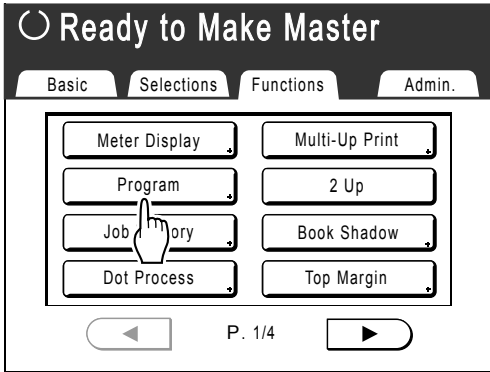

Note:

- If [Program] button is already highlighted, touching it will again display the Program screen, and not the Rename a Program screen. Touch [Cancel Job] then [OK] to return to Functions screen. Touch [Program] again.

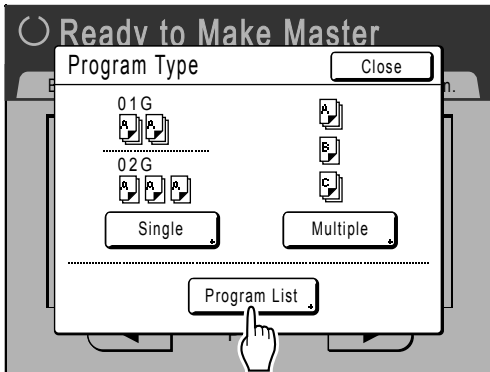

2 Touch [Program List].

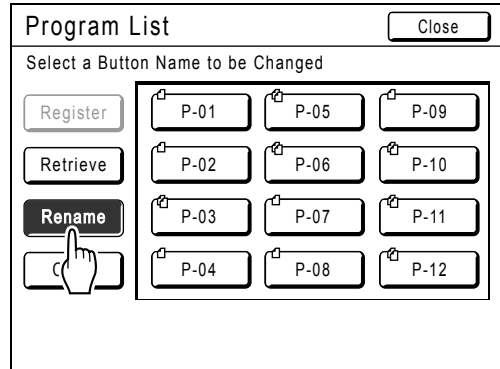

3 Touch [Rename].



Note:

- Each Program button has an icon on top left.  indicates Single Page Mode Program,  indicates Multi-Page Mode Program.

4 Select a program to rename.

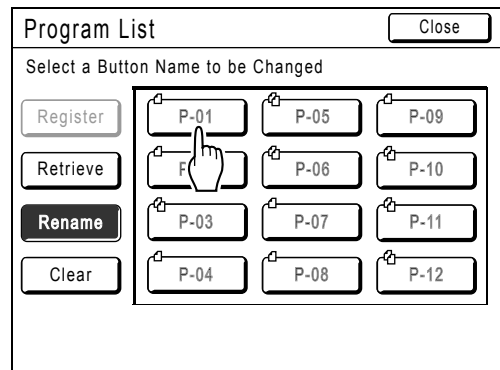

5 Touch the character buttons to enter a new name.

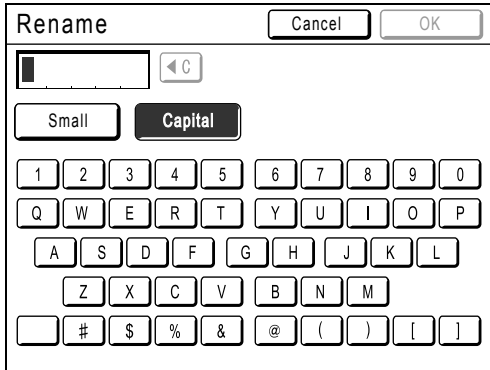

Change capitalization by selecting the **[Small]** or **[Capital]** button. [p.133](#)

Note:

- To delete the current name, touch **⬅C** button or press the **(C)** key.

6 When entered, touch [OK].

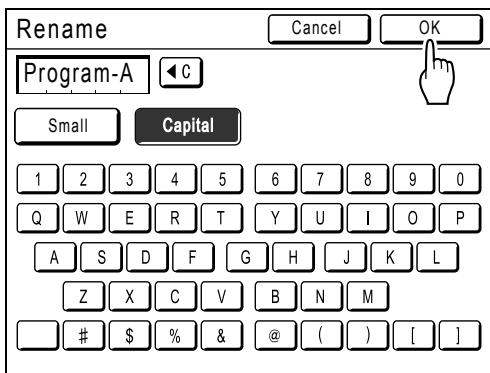

The following screen appears.

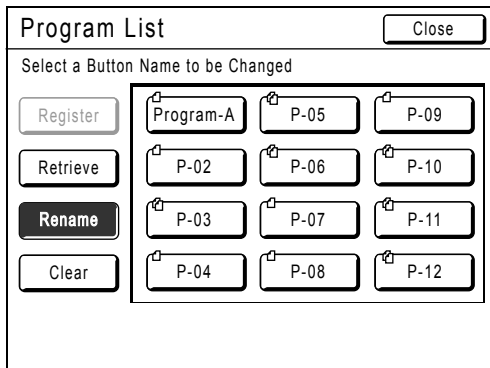

Returns to the Program List screen. The program is renamed.

Tip: Rename screen

◆ Small

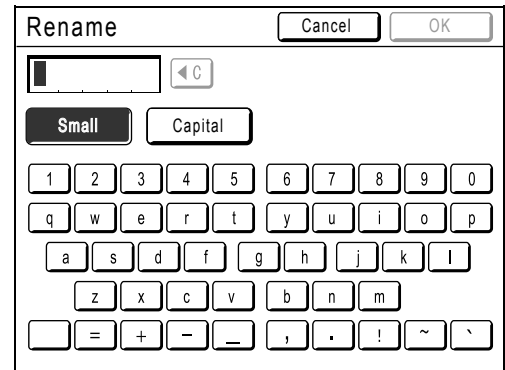

◆ Capital

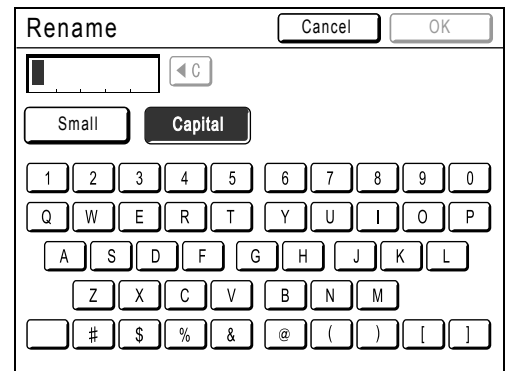

Note:

- You can enter up to 10 characters.
- Print Quantity Keys may also be used for entering numbers.
- ⬅C** button or **(C)** key clears previously saved or current entry. Touch to clear one character at a time.

Clearing Programs

1 Display the Program List screen.

Follow steps 1 to 2 in "Retrieving a Program" (p.129).

2 Touch [Clear].

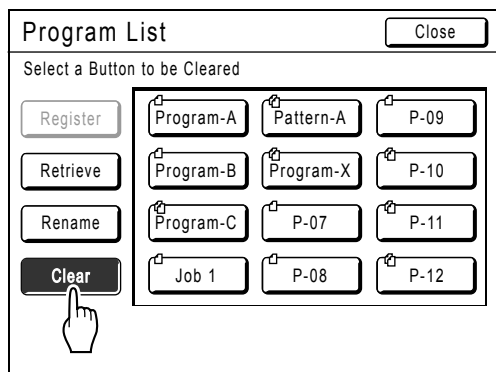

3 Select a program to clear.

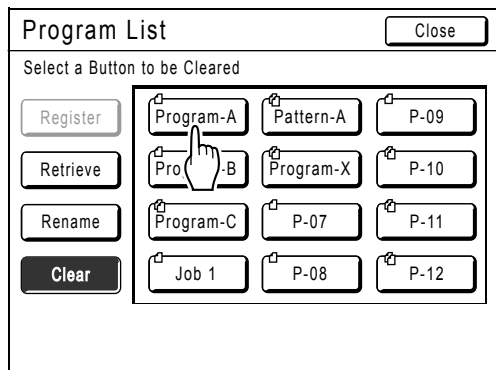

4 Touch [OK].

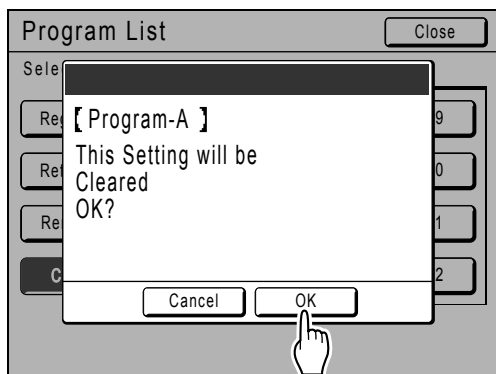

The following screen appears.

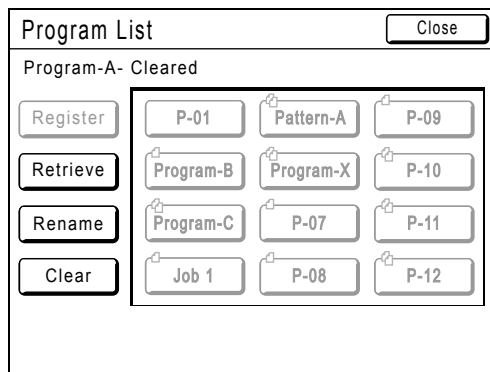

Returns to the Program List screen. The program is cleared.

Making changes to Stored Programs

1 Retrieve a program to modify.

Follow steps 1 and 3 in “Retrieving a Program” (p.129).

2 Make changes to the Program.

Modify number of copies or sets in the current screen.

Note:

- See “Setting Up for Programed Printing” (p.127) for details on how to set up a program.

3 Touch [Revise].

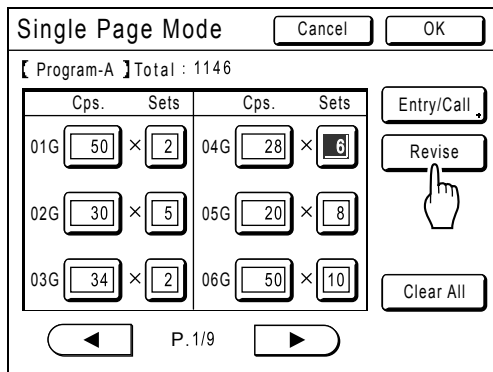

4 Touch [OK].

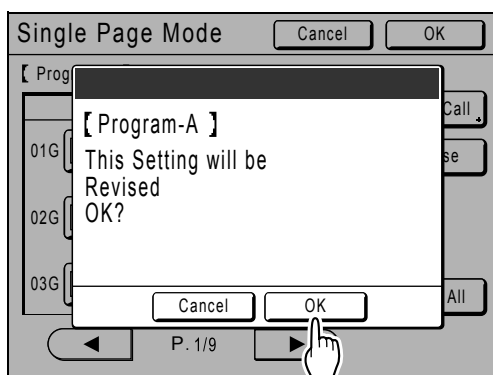

The following screen appears.

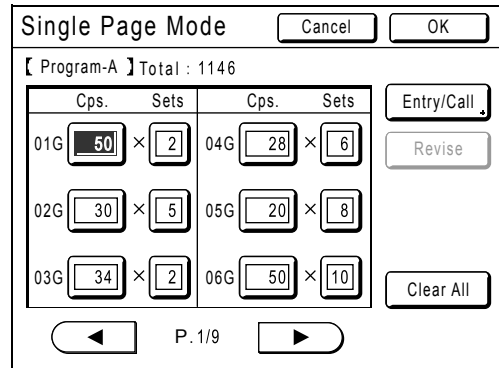

Returns to the Program screen. “Program” settings are updated (overwritten).

Using Job Memory Functions [Job Memory]

You can save combinations of settings. This function is called “Job Memory”. Simply retrieve those “Job Memory” settings when doing a similar print job. Up to 10 jobs can be saved.

The following attributes can be saved to “Job Memory”.

◆ MasterMaking/Print

Image	Max. Scan	Print Density	Sorter* ¹
Dot Process	Book Shadow	Print Position	Job Separation* ¹
Contrast	Multi-Up Print	Paper Feed Adj.	Auto Page Renewal
Ink Saving	Top Margin	Jump Wing Control	Separation Fan
Size	Side Margin	Auto Process	Suction Fan
Margin+	Print Quantity	Interval	
Paper Size	Print Speed	ADF Semi-Auto* ¹	

*¹ Available with optional device

Open the Job Memory screen by either;

- Touching **[Functions]** then **[Job Memory]** on the Touch Screen.
- Press the  key on the Print Quantity Keys.

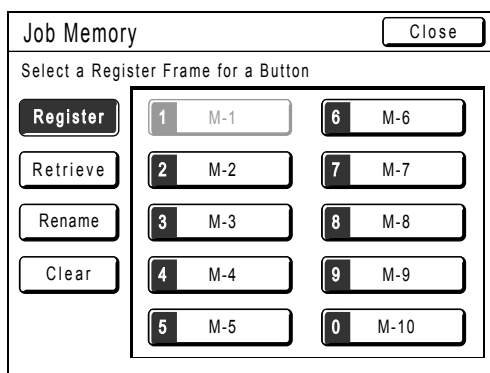

In the following instructions, the method of opening the Job Memory screen with the Touch Screen will be used.

Storing Job Memory

- 1 Set various settings for a print job.
- 2 Touch [Functions] on the Master Making Basic Screen.

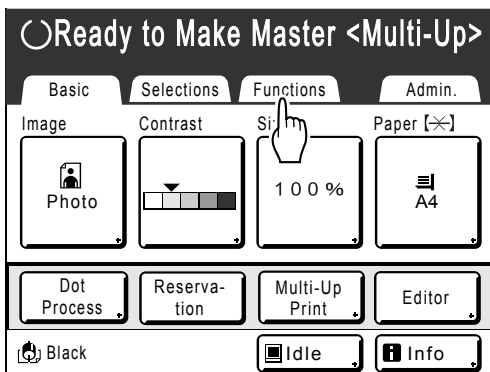

- 3 Touch [Job Memory].

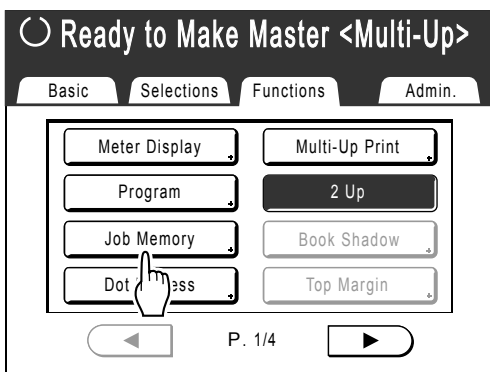

- 4 Touch an unused button.

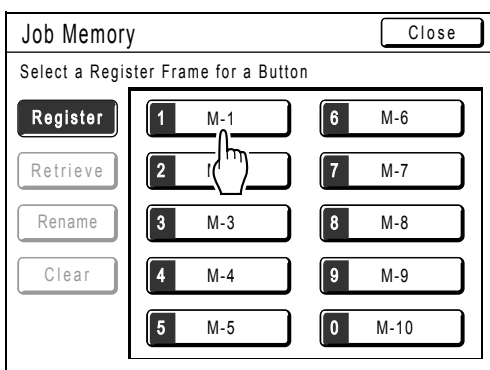



Unused buttons are displayed with a solid line. Used buttons are grayed-out and are not available.

Note:

- If you pressed the  key to open the screen, first touch [Register] then select an available button.

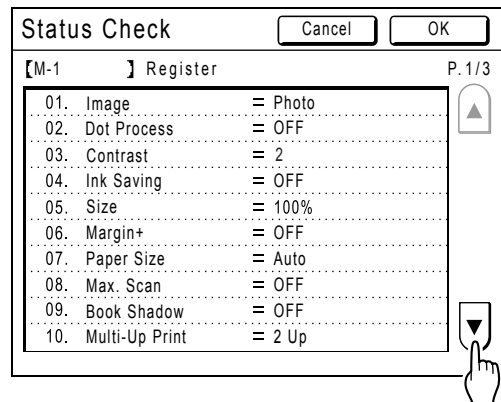
- 5 Confirm settings.



Touch  and scroll down to check all items.

Note:

- To change a setting, touch [Cancel] and start over again. (Return to step 1.)

- 6 Touch [OK].

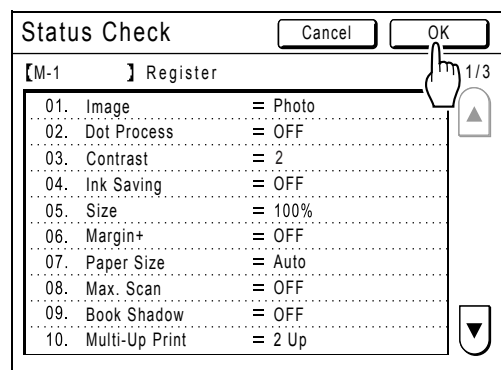

The following screen appears.

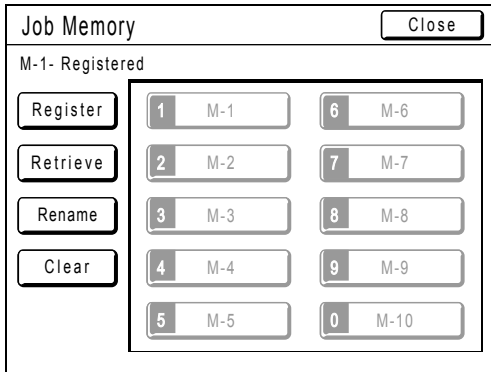

Returns to the Job Memory screen. Settings are updated.

Each job memory can be named for your convenience. See step 3 in “Renaming a Job Memory” (p.139).

Renaming a Job Memory

- 1 Touch [Functions] on the Master Making Basic Screen.**

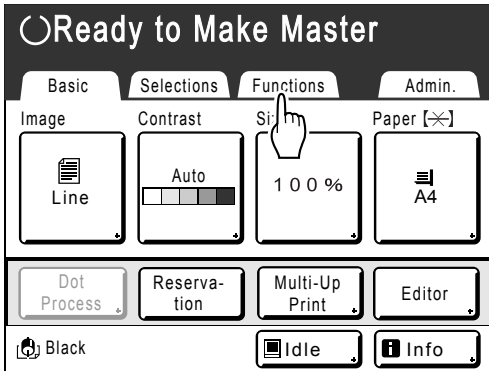

- 2 Touch [Job Memory].**

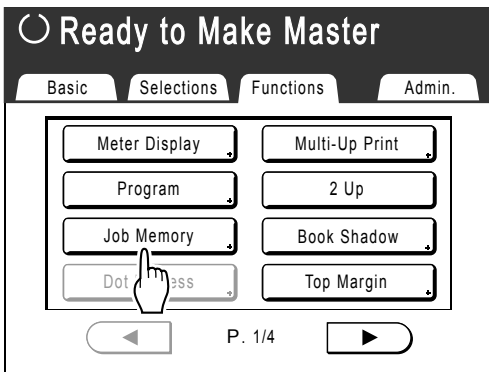

- 3 Touch [Rename].**

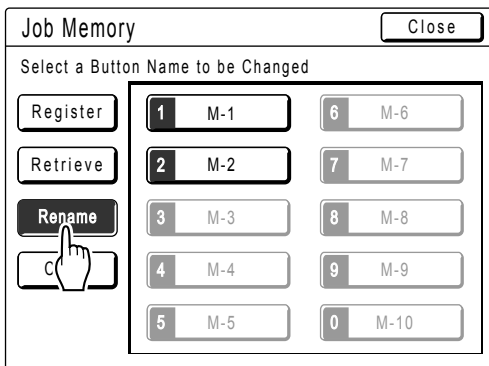

- 4 Select a Job Memory to rename.**

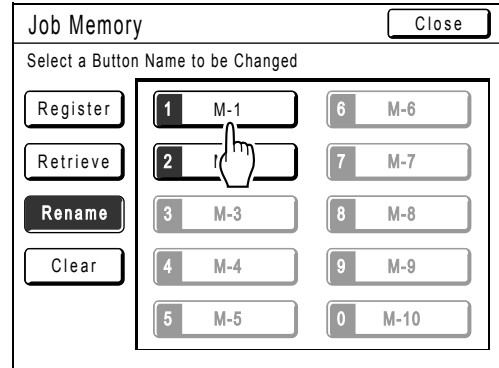

Unregistered buttons are grayed-out and are not available.

- 5 Touch the character buttons to enter a new name.**

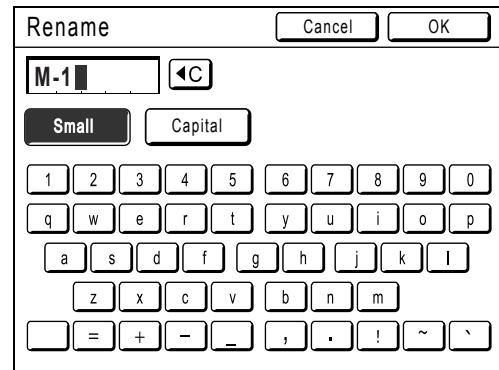

Change capitalization by selecting the **[Small]** or **[Capital]** button.

☞ p.133

Note:

- To clear the current name, touch **⏪** button or press the **(C)** key.

6 When entered, touch [OK].

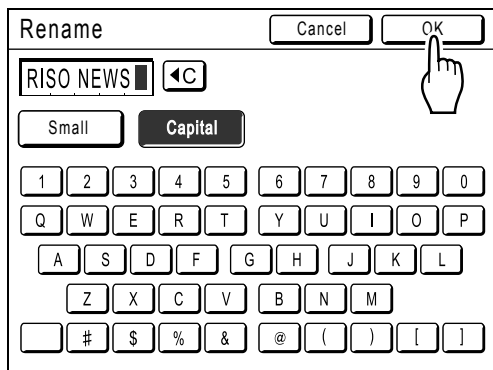

Returns to the Job Memory screen. The name is updated.

7 Touch [Close].

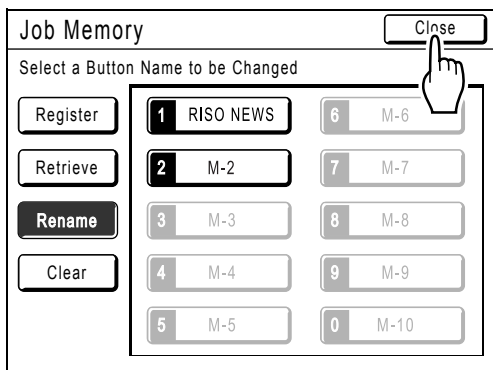

The following screen appears.

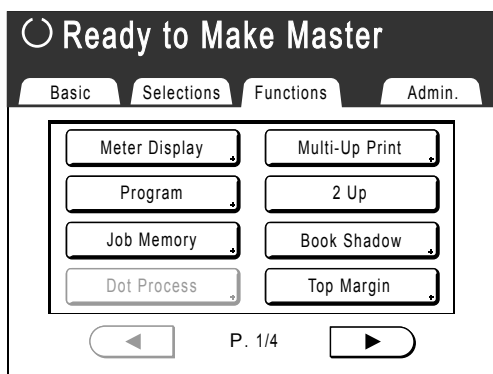

Returns to the Functions screen.

Retrieving a Job Memory and Printing

1 Touch [Functions] on the Master Making Basic Screen.

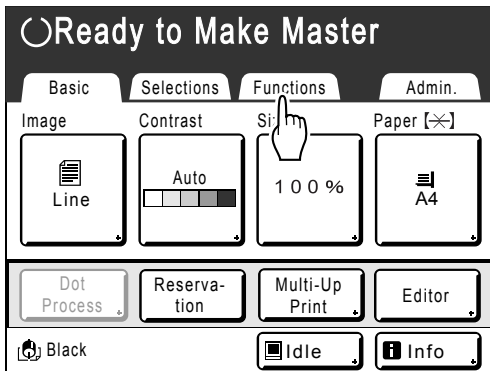

2 Touch [Job Memory].

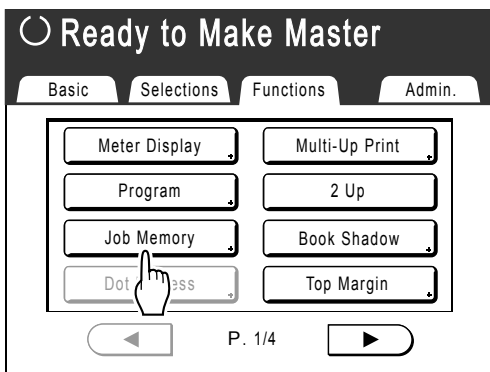

3 Touch [Retrieve].

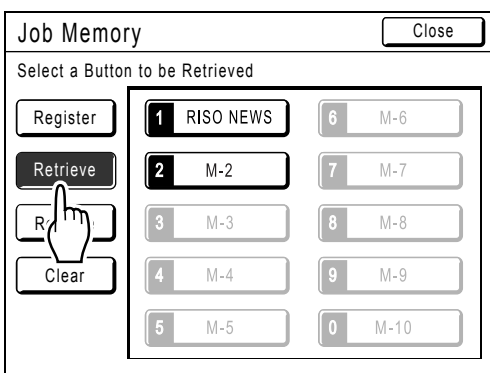

Unregistered buttons are grayed-out and are not available.

4 Select a Job Memory to retrieve.

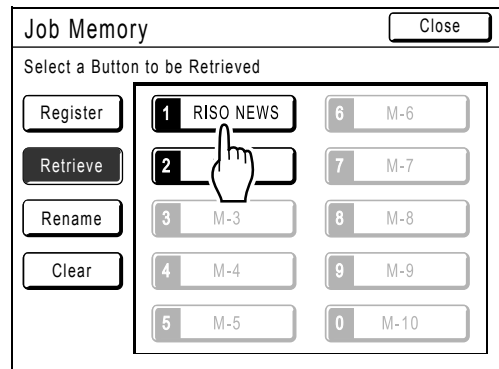

Note:

- A job setting can also be retrieved using the Print Quantity Keys.
M-1 to 9: **1** to **9**
M-10: **0**

5 Confirm the settings and touch [OK].

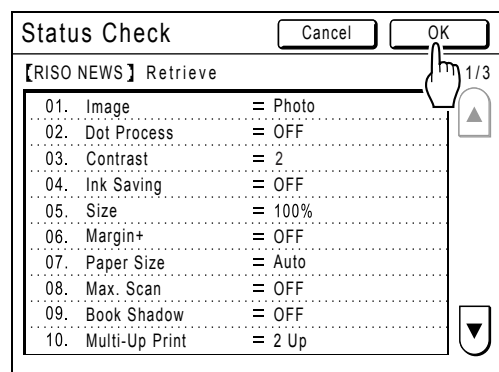

The following screen appears.



Returns to the Functions screen. Ready to print using the retrieved job settings. Continue with the normal printing processes.



Note:

- To cancel a retrieved job memory, press the  key.

Tip:

Quick Retrieval

A job setting can be retrieved via hardware keys without touching the Touch Screen.

For example, to retrieve and print job M-2, press the , ,  key in that order. M-2 is retrieved and starts the master-making process.

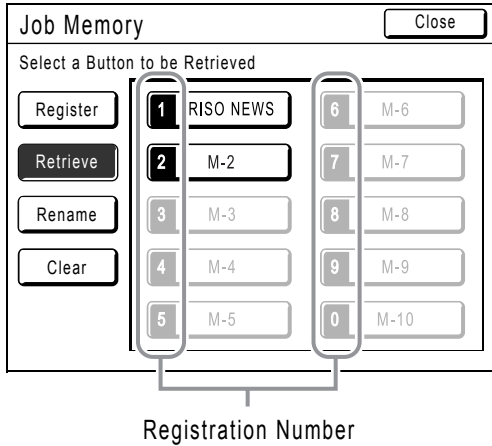

Clearing Job Memory

1 Touch [Functions] on the Master Making Basic Screen.

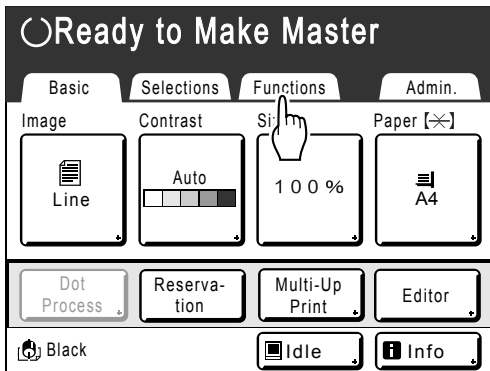

2 Touch [Job Memory].

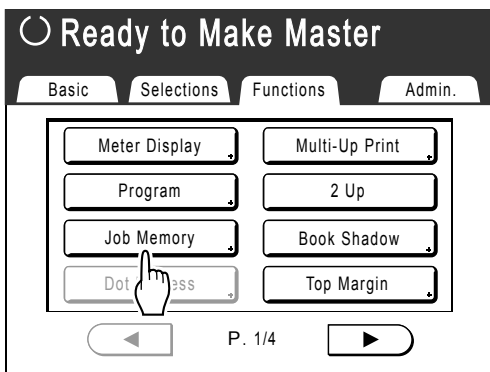

Important!:

- Make sure it is the job setting you want to delete.
- Once the Job Memory is cleared, it cannot be recovered.

3 Touch [Clear].

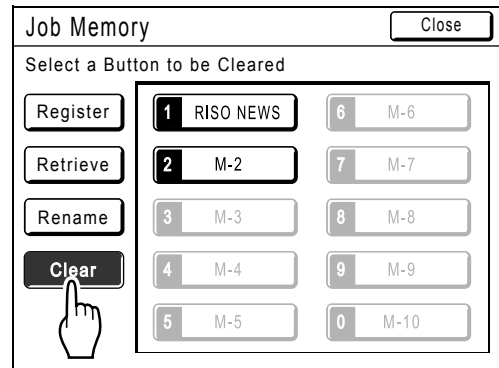

4 Select a Job Memory to clear.

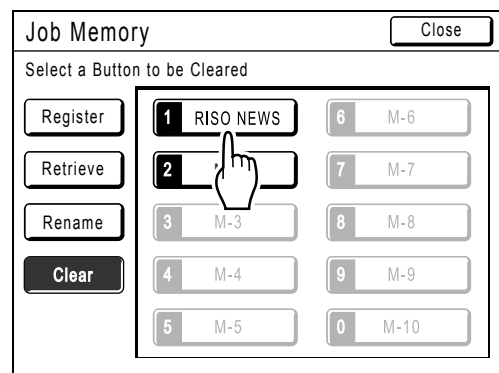

5 Touch [OK].

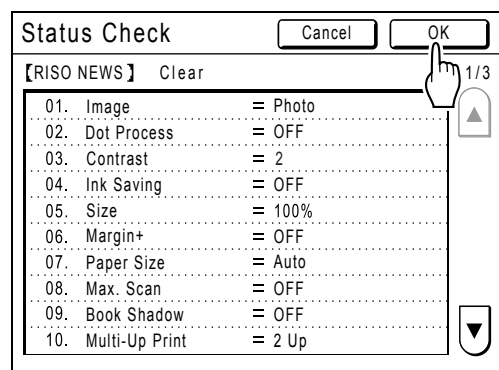

6 Touch [Close].

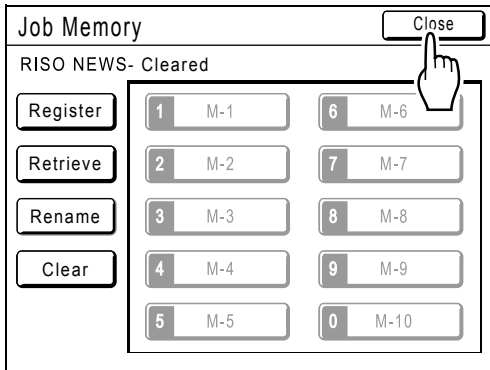

The following screen appears.

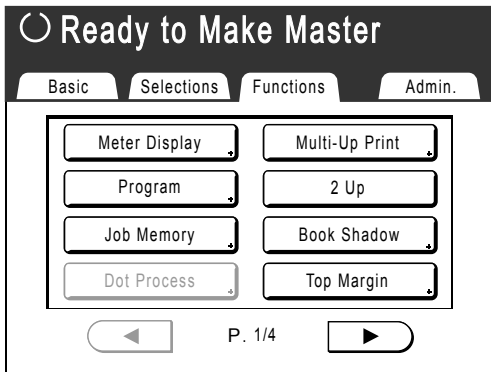

Returns to the Functions screen.

Extending the Reserve Period [Reservation]

This function is useful when the machine is connected to a computer. When the machine is inactive for a certain period of time, it determines that the current job is completed, even if the actual printing is still under way. If another person accidentally initiates another job from the computer, this will cause a new master to be made, discarding the current one.

By extending “Reserve Period”, such interruption can be prevented. We recommend that you activate the “Reservation” setting when temporarily pausing a job or when printing leaflets, etc. to prevent interruption.

Note:

- Select from 5, 10, or 30 minutes as the “Reserve Period” on the Admin. screen. The factory default is 5 minutes.
☞ p.165
- The following operations do not count towards reservation period.
 - When the machine is operating (making a master, printing, confidential action, idling, etc.)
 - When the Job Separator (option) is operating
 - When Control Panel buttons are being entered
 - When the setup screen for some function is displayed
- Auto Sleep and Auto Power-OFF will be disabled during the reservation period.
Auto Sleep/Auto Power-OFF: timer re-activates after the reservation period is up.
Power-OFF Schedule: Will not shut off until next day on time.
☞ p.165

1 Touch [Functions] on the Master Making Basic Screen.

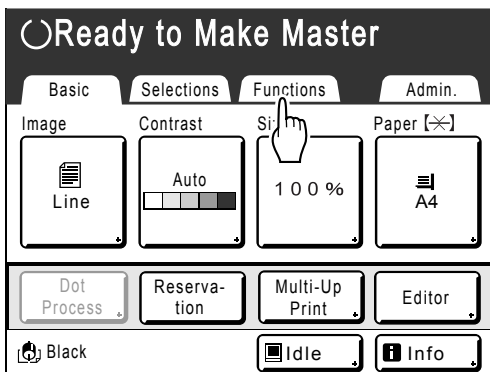

2 Touch [Reservation].

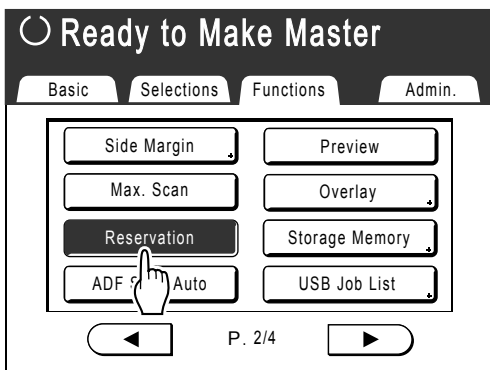

Reservation period is extended.

Idling Action [Idling Action]

When the machine has not been used for an extended period of time, or when the Print Drum (Cylinder) is replaced, the first several copies may be printed too light. By performing “Idling Action” before making a master, high print quality may be instantly achieved and reduce paper waste.

Important!:

- “Idling Action” is effective only in conjunction with the master-making process. When performing print processes only, “Idling Action” will have no effect.

Note:

- To perform “Idling Action” automatically when making a master after a specified period of time since the last print job, set “Auto Idling” on the Admin. screen.
p.166

1 Touch [Functions] on the Master Making Basic Screen.

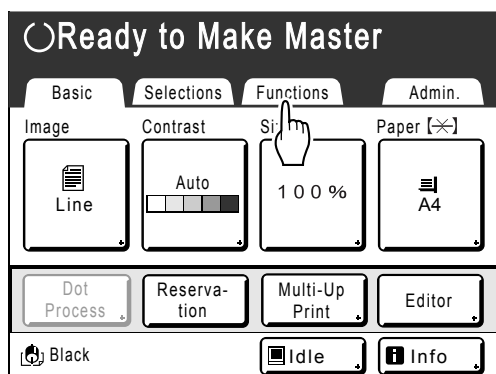

2 Touch [Idling Action].



① appears on screen.

3 Press the key.

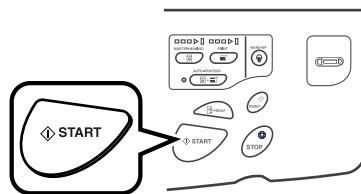

The following screen appears.

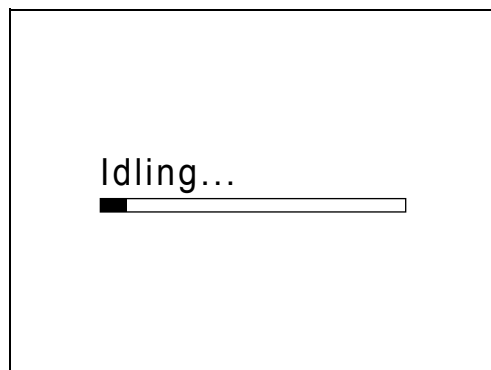

After “Idling Action” has been finished, the master-making process is started.

Note:

- Remember to load the originals before pressing the  key as the master will be made immediately after “Idling Action” finishes.

Reproducing the Master

[Renew Page][Auto Page Renewal]

The data from the last master-making process is temporarily stored on the machine.



Using this data, another master can be reproduced without repeating steps to scan the same original.

You can “Rotate” the original and recreate a master.

“Auto Page Renewal” is a function that automatically recreates a master when a specified number of pages are printed. If you are printing a large-volume job of thousands or tens of thousands of copies, the master may degrade before the job is completed.

If you set “Auto Page Renewal” to “ON” prior to starting a large-volume print job, a master will be automatically re-created when the specified number of copies is reached (Auto Renewal Point). This allows you to maintain a consistent print quality from start to finish.

Note:

- “Renew Page” works with data sent from a computer as well. However, if multiple pages exist, only the last page will be processed with “Renew Page”.
- “Renew Page” function is not available:
 - immediately after startup
 - after pressing the  key
 - after performing “Confidential”
 - after performing “Multi-Up Print”
 - after performing “Book Shadow”
 - when an error has occurred during master-making
 - after master-making for Data Output Mode (when the optional Key Card Counter is installed.)
- The number of pages in the proof copy when using “Auto Page Renewal” can be adjusted using “Admin.”.  p.166
- Once the print position has been adjusted the new position is saved when master-making is resumed, avoiding the need for readjustment.

Using Page Renewal

1 Touch [Functions] on the Print Basic Screen.

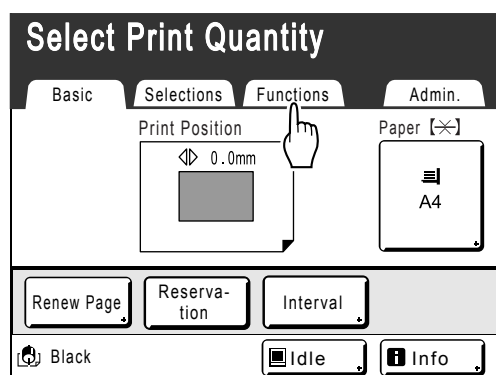

2 Touch [Renew Page].

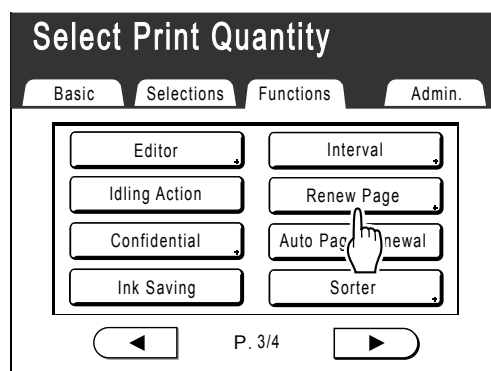

Note:

- If you touch and select **[Rotate]**, you can rotate the original 180 degrees for renewing the master.
- When “Rotate” is set, the machine rotates 180 degrees for renewing the master while executing “Auto Page Renewal”.
- To cancel “Rotate”, touch **[Rotate]** again.

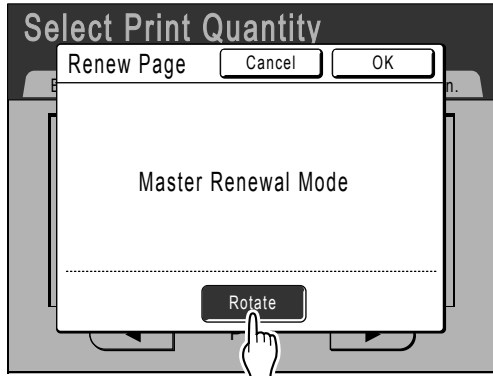

3 Touch [OK].

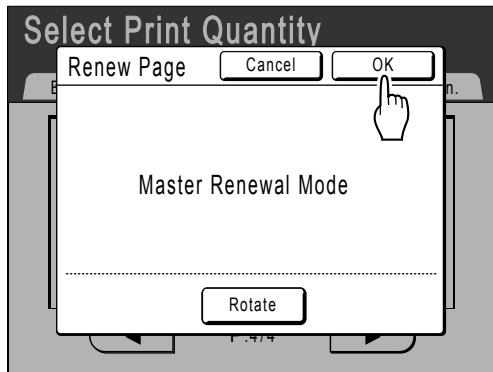

The following screen appears.

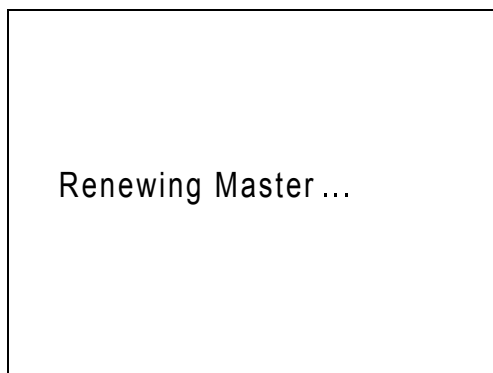

“Renew Page” begins reproducing the master.

Using Auto Page Renewal

In order to use “Auto Page Renewal”, you must enable it in “Admin.” prior to use.

If “Auto Page Renewal” is activated and “Auto Page Renewal” is set to “ON”, “Auto Page Renewal” can be executed during a print job.

Important!:

- If “Auto Page Renewal” is not activated in “Admin.”, “Auto Page Renewal” cannot be set to “ON”.
☞ p.166
- The “Auto Page Renewal” is set to “OFF” in the following instances.
 - When printing with “Program”
 - When the  key is pressed
 - When attempting to process the next job with direct print

Turning ON “Auto Page Renewal”

1 Touch [Functions] on the Print Basic Screen.

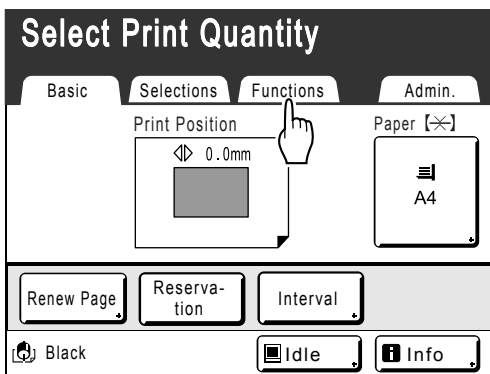

When you print with these settings, “Auto Page Renewal” will be executed after the specified number of copies are printed.

Note:

- If [Auto Page Renewal] is grayed-out, go to “Admin.” and turn “Auto Page Renewal” ON.
☞ p.166

2 Touch [Auto Page Renewal].

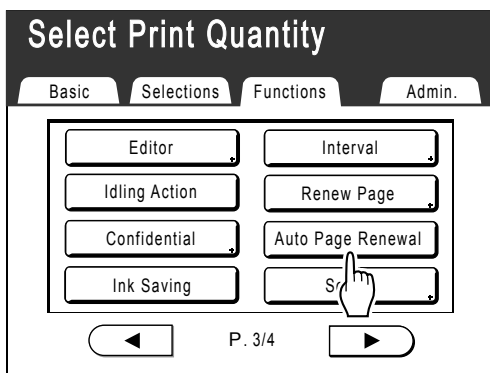

“Auto Page Renewal” is activated.

Proof and Print (with the ADF unit (Option) installed)

[ADF Semi-Auto]

Selecting “Auto Process” with the ADF unit (Option) installed automatically performs the complete printing job, but you cannot make proof copies, or any necessary adjustments of each master. To pause for check after printing a proof copy of each master, select “ADF Semi-Auto”.

Important!:

- Turn “Auto Process” OFF when using “ADF Semi-Auto”.
☞ p.61

Note:

- The default “ADF Semi-Auto” can be set on the Admin. screen.
☞ p.163

1 Touch [Functions] on the Master Making Basic Screen.

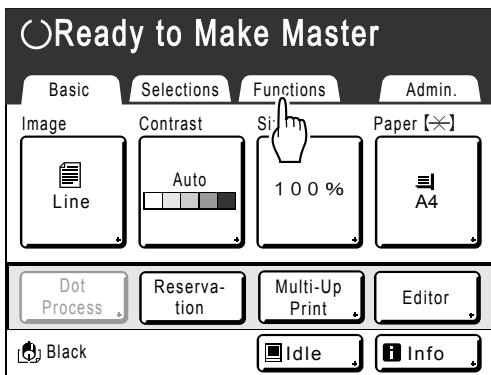

2 Touch [ADF Semi-Auto].

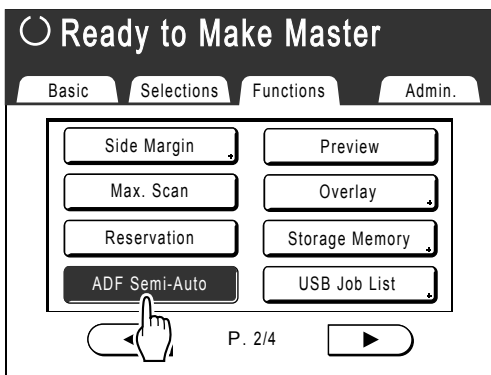

“ADF Semi-Auto” is selected.

Note:

- If [ADF Semi-Auto] is not displayed (or is grayed-out), turn  OFF on the Control Panel.

3 Place original(s) in the ADF unit (Option).

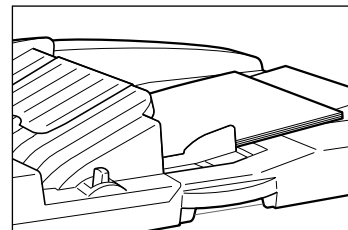

The ADF unit (Option) detects the document, and automatically opens the Master Making Basic Screen

4 Enter the number of copies using the Print Quantity Keys.

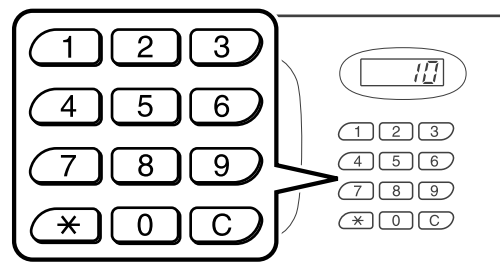

The number is displayed on the Print Quantity Display.

Note:

- To change the number, press the **C** key, then re-enter the correct number.

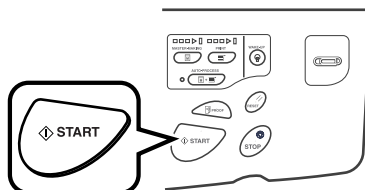
5 Press the  key.

After a master is made, a proof copy is printed and the job stops.

6 Check the proof copy.

Make adjustments if needed.

7 Press the  key.

The machine prints specified number of copies. Master for the next original is made, its proof copy is printed, then the machine stops again.

Repeat steps 6 and 7.

Showing Usage Status [Meter Display]

The machine can record and display the following information:

- A4/Letter and Under: Total number of copies A4/Letter-sized and smaller that have been printed.
- Above A4/Letter: Total number of copies larger than A4/Letter that have been printed.
- Total: The total number of copies printed by the machine.
- Master Count: The total number of masters made by the machine.
- Print Drum (Cylinder) Meter: The number of copies that have been printed with the current drum (cylinder).
- Job Count: Start and stop as needed.
For example, to keep track of the number of copies made in a day, set “Job Count” to 0 in the morning, and check the counter at the end of the work day to get the count.

Note:

- When using more than one Print Drum (Cylinder), install the Print Drum (Cylinder) for which you need information before displaying the Meter Display screen.

1 Touch [Functions] on the Master Making Basic Screen.

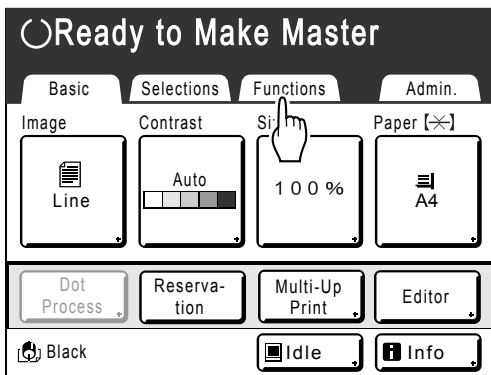

2 Touch [Meter Display].

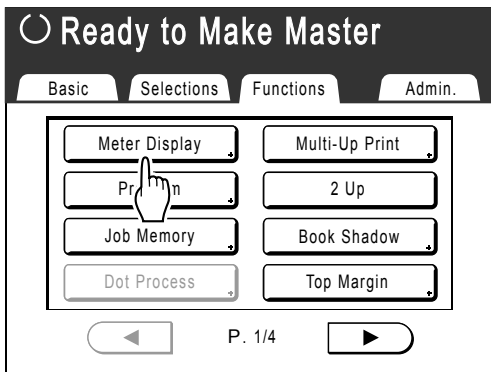

3 Review counts.

Meter Display		Close
A4/Letter and Under	25,000,000	
Above A4/Letter	25,000,000	
Total	50,000,000	
Master Count	5700	
Print Drum Meter	600,000	
Job Count		999 ◀C

Note:

- Using the “Job Count”
 - 1) Touch ◀C to set the counter to 0.
 - 2) Touch [Close] to close the Meter Display screen. Operate the machine as normal.
 - 3) To display and review the Job Count, follow steps 1 and 2.

4 Touch [Close] to close the window.

Returns to the Function screen.

Rotating the Original 180 Degrees to Make a Master [Rotate]

When you are direct printing, you can rotate the original data received from a computer 180 degrees to make a master.

Important!:

- “Rotate” can also be set from the printer driver, but if it is set on both the machine and printer driver, the job will print without rotating.

1 Touch [Functions] on the Master Make Basic Screen.

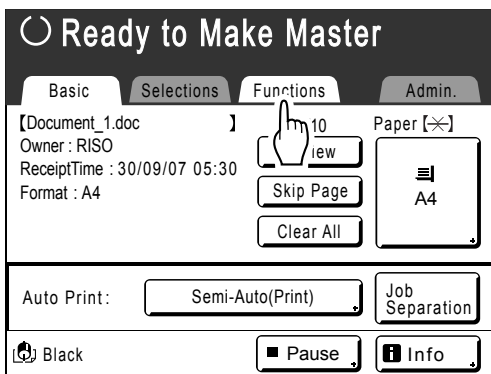

2 Touch [Rotate].



“Rotate” setting is updated.

Checking User Counters [ID Counter Report]

Each user can output counter data (number of prints, etc.) when checking usage status. When you set the reminder date, the reminder screen is displayed on the set date of each month. This is useful when reporting the counter data to the administrator.

Important!:

- To manage usage status correctly, the following setting is required. If you do not make the following setting, you cannot count the number of prints/masters correctly.
 - Set **[Management Level]** to **[High/Full Management]** in User Management. [p.104](#)
 - If you print from the computer, be sure to use “ID Print”. See the “RISO Printer Driver User’s Guide” for detail.

Report Output

The number of print/master, etc. of each user can be output.

◆ Output method

Counter data can be outputted by following methods.

- Print
Prints the counter data.
- E-mail
E-mail attached with the counter data is sent to the e-mail addresses set as the destination. The mail settings must be set in advance. For details on mail settings, the optional RISO Network Card is required. For details, see the “RISO Network Card User’s Guide”.
- USB Flash Drive
Outputs the counter data to the USB Flash Drive. USB Flash Drive must be connected to the USB slot in advance.

Note:

- By using the “RISO Utility Software” (RISO COPY COUNT VIEWER) included on the provided CD-ROM, the counter data output to the USB Flash Drive can be managed by a computer. For details, see the “RISO Utility Software User’s Guide”.

Setting the reminder date

For regular counting, a reminder date can be set. The following screen is displayed on the set date.

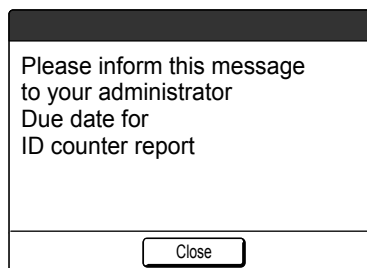

When setting the reminder date between the 29th - 31st, and if the number of days in the month is less than this range such as in February, the reminder screen is displayed on the last day of the month.

Outputting the Counter Report

1 Touch [Functions] on the Basic Screen for each mode.

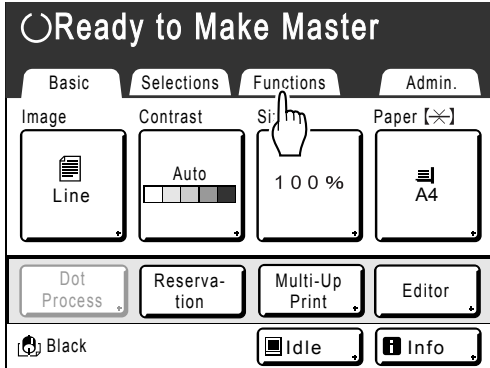

2 Touch [ID Counter Report].



3 Touch the button of the desired output method.

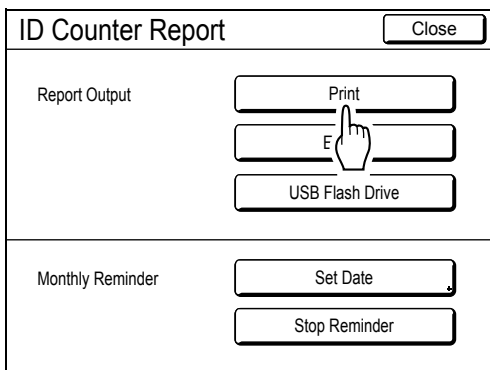

If the mail setting is not set, **[E-mail]** is not available.

Consult your dealer (or authorized service representative) about mail settings.

If the USB Flash Drive is not connected, **[USB Flash Drive]** is grayed-out and is not available.

The following screen appears.

◆ When touching [Print].

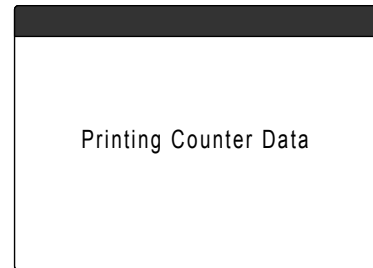

◆ When touching [E-mail].

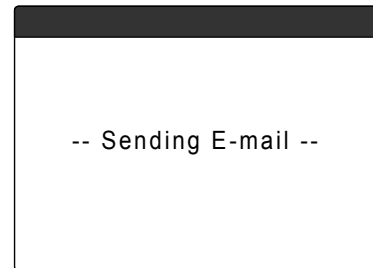

◆ When touching [USB Flash Drive].

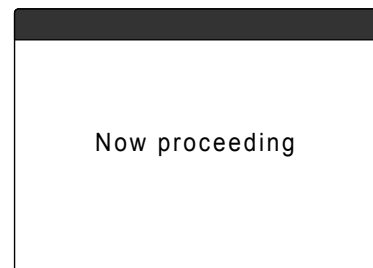

Returns to the Basic screen after output.

Setting Up the Monthly Reminder

1 Touch [Functions] on the Basic Screen for each mode.

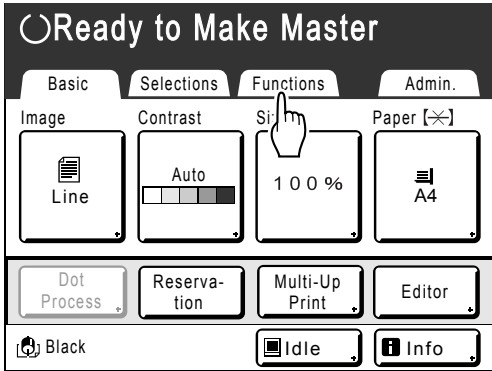

2 Touch [ID Counter Report].



3 Touch [Set Date].

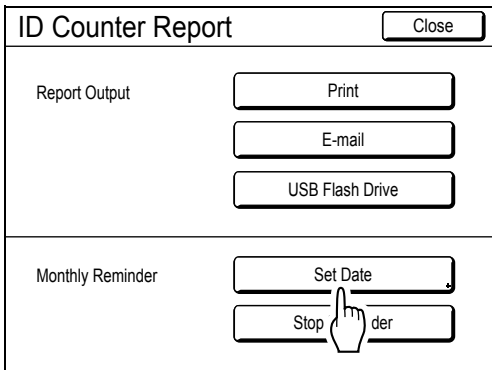

4 Touch Date input box.

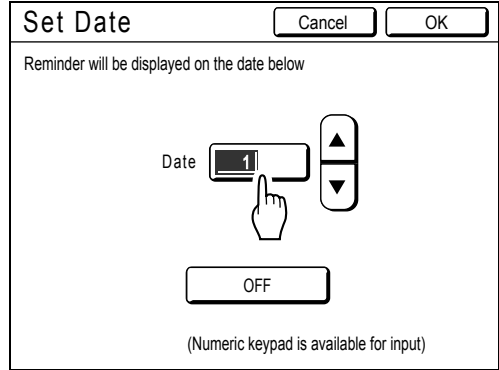

If the [Date] button is grayed-out, touch [OFF] and input the date.

5 Touch [Up] or [Down] to set the reminder date.

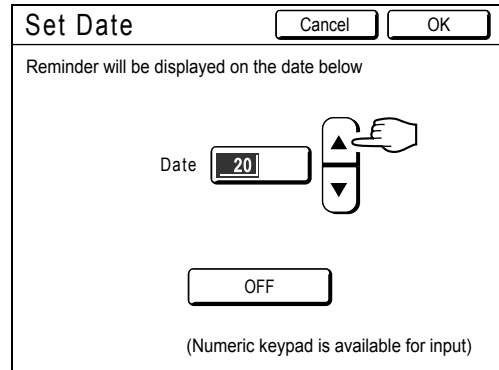

Note:

- Print Quantity Keys can also be used to enter numbers.
- The set date can be selected between 1 and 31.
- If you are not setting the reminder date, touch [OFF].

6 Touch [OK].

Set Date Cancel OK

Reminder will be displayed on the date below

Date ▲
▼

OFF

(Numeric keypad is available for input)

Returns to the ID Counter Report screen.
The reminder date is updated.

7 Touch [Close].

ID Counter Report Close

Report Output Print
E-mail
USB Flash Drive

Monthly Reminder Set Date
Stop Reminder

Returns to the Functions screen.

Note:

- Once the reminder date is set, a “reminder screen” is displayed on each reminder date. In fact, this message is displayed each time the machine is turned ON until the counter report is output. If you do not want to output the counter data on the set date of this month, touch **[Stop Reminder]**. The reminder screen is not displayed until the reminder date of the next month.

Customizing the Direct Access Area [My Direct Access]

Normally, the functions displayed in the Direct Access Area of the Basic Screen are already registered by default setting or changed by the administrator. However, if User Management is set up, each user can register the functions displayed in the Direct Access Area using “My Direct Access”. The functions that can be displayed in the Direct Access Area can individually be registered in each mode (Master Making/Print/Scanning). Up to 4 functions can be registered.

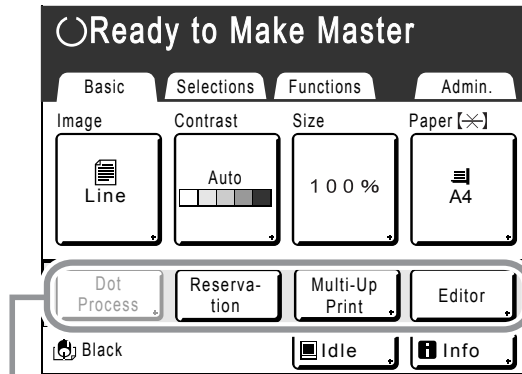

Direct Access Area

“My Direct Access” kept by each user can be displayed after the user has been identified and cannot be changed by other users.

Important!:

- “My Direct Access” can be set when “Management Level” is set to “High/Full Management” in “User Management”.

Note:

- If “My Direct Access” is not set, the functions registered via the usual methods are displayed in the Direct Access Area. (p.171)

1 Touch [Functions] on the Basic Screen for each mode.

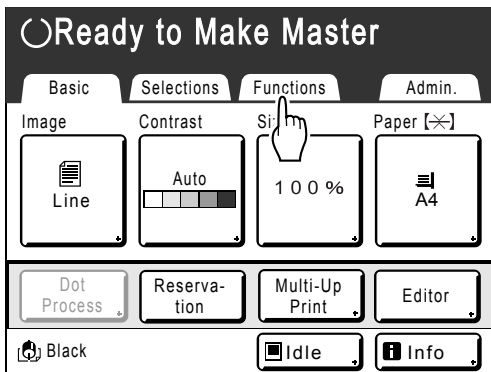

2 Touch [My Direct Access].



If “Management Level” is not set to “High/Full Management” in “User Management”, the [My Direct Access] button is grayed-out and is not available.

Note:

- Consult your administrator for Management Level.

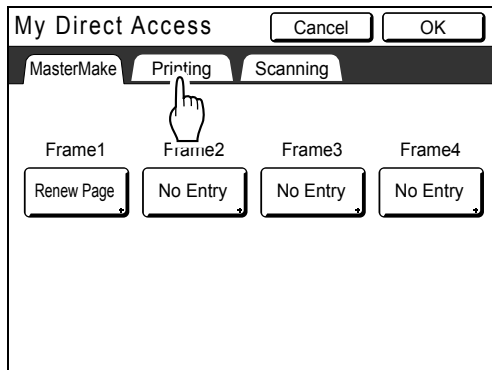
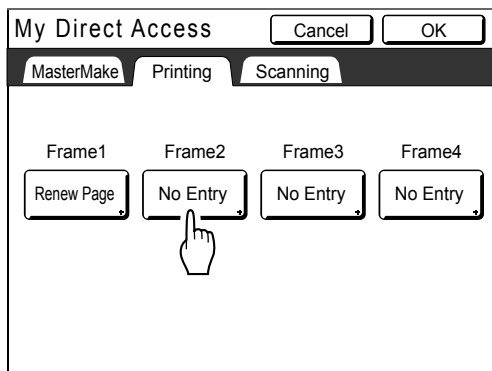
3 Select a mode tab to register new buttons.**4 Select a button to assign a function to.**

If the button has a function already assigned to it, the newly selected function will overwrite the previous function.

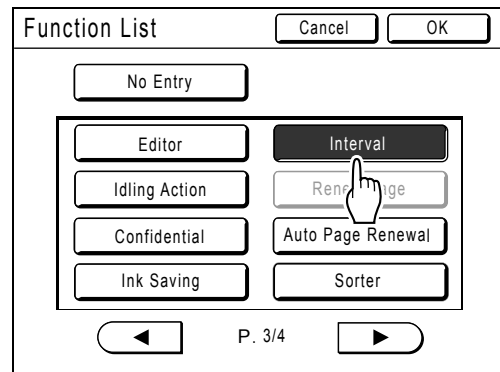
5 Select a function to assign.**Note:**

- Touch ◀ or ▶ to display more functions if necessary.
- To remove a function that is accidentally assigned, touch **[No Entry]**.
- Functions already assigned are grayed-out and are not available.
- Some functions display only when optional devices are installed.

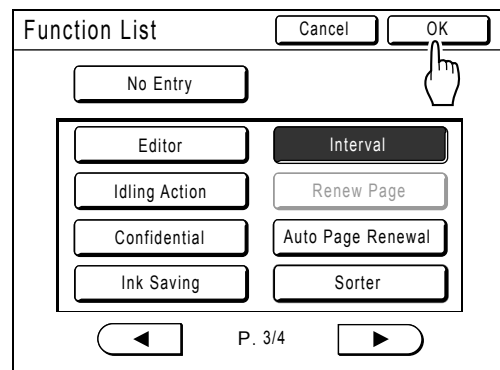
6 Touch [OK].

Returns to “My Direct Access” screen. The selected functions are added. To add more functions or to replace a button with another function, repeat step 3 to 6.

7 Touch [OK].

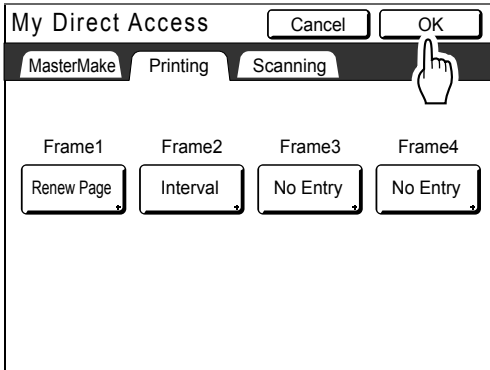

The following screen appears.



Returns to the Functions screen.

Changing Default Settings [Admin.]

The default settings can be modified to best suit your needs.
They may be edited as needed.

Important!:



- If the administrator is registered in User Management, only the administrator can change the **[Admin.]** settings. (This operation requires input of the administrator's PIN code or connection of the registered USB Flash Drive.)
☞ p.168, ☞ p.104
- Depending upon the usage environment, the "Admin." features may not be available (the "Admin." tab may not be displayed).
Consult your dealer (or authorized service representative) for details.

Note:

- The default settings are the values restored when the machine is turned ON or when the  key is pressed.



Configurable Functions

==:Initial setting (factory default)

Display Access Button	Functions	Description
[Display]	DirectAccess Entry Store frequently-used functions on the Basic Screen for each mode.	☞ p.171
	Selections Entry Store frequently-used functions on the Selections screen for each mode.	☞ p.171
	Display Priority Select first screen to display following the Startup. Note: <ul style="list-style-type: none"> • The Mode Screen is available only when "Mode Key Pattern" is set to "Mode Selection". 	Mode Screen/RISO Print/ (Scanning)
	Mode Key Pattern Select screens to display when the  key is pressed. [Mode Selection] Pressing the  key will open the Mode Screen no matter which screen you are currently on. [Loop] The screen changes as shown below when the  key is pressed. <ul style="list-style-type: none"> • Normally: "Master Making Basic Screen" ←→ "Print Basic Screen" • When the optional Document Storage Card DM-128CF or USB Flash Drive is attached: "Scan Basic Screen" ←→ "Master Making/Print Basic Screen" 	Mode Selection/Loop

Display Access Button	Functions	Description
[Display]	Start-Up Screen Select an animation to display at Start-up.	Logo(RISO)/ <u>Logo(EZ)</u> /Character
	Metric/Inch Switch (For EZ590U only) Change the format for displaying measurements to metric or inches (imperial).	<u>Inch</u> /Metric
	Display Adjustment Change background color (colour), density and brightness of the Touch Screen.	Background: <u>White</u> /Blue Display Density -5, -4 ... -1, <u>0</u> , +1 ... +4, +5 Backlight Lightness: -2, -1, <u>0</u> , +1, +2
	Displayed Language Select the language displayed on the screen. Important!: <ul style="list-style-type: none"> • Contact your dealer (or authorized service representative) to change the settings. 	#01, #02, #03 ...

Display Access Button	Functions	Description
[Default]	Image Processing Change the default setting for the “image processing mode”.	<ul style="list-style-type: none"> • <u>Line</u> • Photo (Standard, Portrait, Group) • Duo (Line, Photo/Shadow off) • Pencil (Darker, Lighter)
	Scanning Contrast Change the default setting for the “scanning contrast”.	<ul style="list-style-type: none"> • Contrast Range: Lighter/<u>Standard</u>/Darker • Contrast: 1, 2, 3, 4, 5, <u>Auto</u>
	Reproduction Size Change the default setting for the “size”.	<u>100%</u> , Auto
	Print Speed Change the default setting for the “print speed”.	1, 2, <u>3</u> , 4, 5
	Print Density Change the default setting for the “print density”.	<ul style="list-style-type: none"> • Print Density Level Lighter, <u>Standard</u>, Darker • Print Density 1, 2, <u>3</u>, 4, 5
	OP Auto Process Change the default setting for the “Auto Process” when an ADF unit (Option), Sorter TM2500 or Job Separator is installed.	<u>ON</u> , OFF
	ADF Semi-Auto Change the default setting for the “ADF Semi-Auto” when the ADF unit (Option) is installed.	ON, <u>OFF</u>
	Auto Process Mode Change the default setting for the “Auto Process”.	ON, <u>OFF</u>
Job Separation Change the default setting for the “Job Separation” when the Job Separator (option) is installed.	ON, <u>OFF</u>	

Display Access Button	Functions	Description
[Default]	<p>Jump Wing Control Change the default positioning of the Paper Jumping Wing.</p> <p>Important!:</p> <ul style="list-style-type: none"> This option is available only when the special paper setting is pre-configured. Contact your dealer (or authorized service representative) to pre-configure this setting. 	ON, <u>OFF</u>
	<p>Paper Ejection Adj Change the default settings for "Paper Ejection Adj." p.95</p>	Separation Fan: OFF, 1, <u>2</u> , 3, 4 Suction Fan: 1, 2, <u>3</u> , 4
	<p>Default Folder When the optional Document Storage Card DM-128CF is attached, change the folder in which to save the data scanned in the scan mode and the folder to save the data sent from the computer.</p>	<ul style="list-style-type: none"> Scan Data Folder: 1-6 folder (Factory default: 1_folder) PC Job Folder: 1-6 folder (Factory default: 1_folder)
[System]	<p>Custom Paper Entry Specify paper dimensions before using non-standard sized paper.</p>	p.174
	<p>Fixed Scan Size Scan the original at the specified standard size regardless of the set original size.</p>	<p>For EZ590: <u>OFF</u>, Ledger, Legal, Letter, LetterR, Statement, Statement R For EZ570: <u>OFF</u>, A3, B4, A4, A4R, B5, B5R, Foolscap</p>
	<p>Folder Renaming When the optional Document Storage Card DM-128CF is attached, changes the folder name of the folder used to save data.</p>	1-6 folder
	<p>CI Select Choose between "Internal CI" and "External CI" settings.</p>	<u>Internal CI</u> , External CI
	<p>Base IP Address Set the IP address for connecting the machine to a network. IP address settings differ depending on the type of network.</p> <p>Note:</p> <ul style="list-style-type: none"> To change an input source, touch the applicable box, or press the  key to rotate options. If the message "Starting Up Network Card" is displayed when touching [Base IP Address], touch [Cancel] and wait for the RISO Network Card (Option) to finish starting up (approx. 1 minute), then try again. 	<ul style="list-style-type: none"> When using a DHCP server [Use DHCP] When entering IP address manually [Manual Input]   or the Print Quantity Keys.
	<p>Margin-Plus Rate Specify default size-reduction rate for the "Margin+" setting.</p>	90 to 99 % (Factory default is 94%)

Display Access Button	Functions	Description
[System]	Clock/Calendar Set the internal clock of the machine. The time/date displays on the i Info screen. ☞ p.201	Year/Month/Day Hour:Minute (Day/Month/Year Hour:Minute)
	Multi-Up Interval Select the interval time (seconds) between first and second scans when using Multi-Up Printing.	<u>15s</u> /30s
	Reserve Period Select a duration of time (seconds) for the inactive machine to receive data from a computer but restricts processing any output command.	OFF/ <u>15s</u> /30s/60s
	Ex. Reserve Period When "Reserve Period" is set, extends the Reserve Period (minutes) to prevent data interruption.	<u>5mn</u> /10mn/30mn
	Auto Clear Select whether to reset all settings to default automatically when the machine is inactive for a set period (minutes).	<ul style="list-style-type: none"> Auto Clear OFF/<u>ON</u> Waiting Time 1-60 mn (factory default is 5 mn)
	Energy Saving Mode Select to activate Sleep Mode or Shutdown Power when the machine is inactive for a set period of time. <ul style="list-style-type: none"> OFF "Energy Saving Mode" is not activated. Power is turned ON/OFF using the power switch. Auto Sleep The machine is standing by to receive data from the computer, but the rest of its functions are powered off. Auto Power-OFF Automatically shuts the power off. (Data cannot be received.) 	<ul style="list-style-type: none"> Energy Saving Mode OFF/<u>Auto Sleep</u>/Auto Power-OFF Waiting Time 1-60 mn (factory default is 5 mn)
	Power-OFF Schedule Set a time of the day to automatically shut power to the machine off. If the machine is in use, or receiving data, power will not shut off.	<ul style="list-style-type: none"> Power-OFF Schedule <u>OFF</u>/ON Shut-Off time Hour: Minute

Display Access Button	Functions	Description
[System]	<p>User Management Set the User Management function.</p> <ul style="list-style-type: none"> • Management Level Set the "Management Level". • Create User Register the administrator and users of this machine. • Rename Group Change the group name. • Reset Counter Reset all user counters for master-making/printing. • Recognized by Set the Recognition and Identification System. 	p.104
	<p>Protect Determine the "Protect" setting.</p>	OFF, ON p.178
	<p>Auto Idling Select whether to perform "Auto Idling" when making a master after a set period of non-use. Also selects a period of non-use before initiating "Auto Idling", as well as the number of idle rotations.</p>	<ul style="list-style-type: none"> • Auto Idling OFF/ON • Non-Use Time 1-12 hour • Rotation 1-3 (times)
	<p>Auto Page Renewal Allows you to set when to recreate a new master. Once the specified number of copies is reached, the master in use is automatically discarded and a new one created. You can also specify the number of proof copies to make after recreating the master.</p>	<ul style="list-style-type: none"> • Auto Page Renewal OFF, ON • Auto Renewal Point 1-9999 copies (Factory default is 1000 copies) • Sample Copy Output 0-99 copies (Factory default is 3 copies)
	<p>Minimum Print Q'ty Set minimum number of copies to print. This prevents master from being made when a smaller quantity is entered for printing.</p> <p>Important!:</p> <ul style="list-style-type: none"> • This setting can be locked to prevent alteration. Consult your dealer (or authorized service representative) for details. 	OFF/ON (2-99 copies)
	<p>Stock Management In order to check current stock quantity, insert the number of consumables purchased.</p> <p>Note:</p> <ul style="list-style-type: none"> • When stock quantity falls below the "Remaining Qty to be notified", a message will appear on the display. • This setting is disabled by factory default. Consult your dealer (or authorized service representative) for details. 	<ul style="list-style-type: none"> • Purchase Qty 0-99 Pcs. • Remaining Qty to be notified 0-99 Pcs.

Display Access Button	Functions	Description
[System]	Beep Sound Select whether to activate a beep sound when a key/button is pressed, or when an error occurs. <ul style="list-style-type: none"> • ON Beeps when any key/button is pressed. Beeps when an event is caused/completed. • Limited Does not beep when keys/buttons are pressed. Does not beep when restarting the machine. • OFF Does not beep. 	OFF/Limited/ <u>ON</u>
[Editor]	Print Colors (Colours)	See RISO Editor User's Guide for details.
	Tool Bar Position	
	Sub Tool Bar	
	Page Orientation	

Customizing the Default Settings

The default settings can be changed when the machine is not in operation. Make sure there is no pending or current Print Job operation.

Note:

- If the administrator is registered in User Management, only the administrator can change the [Admin.] settings. (This operation requires input of the administrator's PIN code or connection of the registered USB Flash Drive.) See p.104
- On the Admin. screen, the current setting is displayed on the right side of each button.

1 Touch [Admin.] on the Basic Screen for each mode.

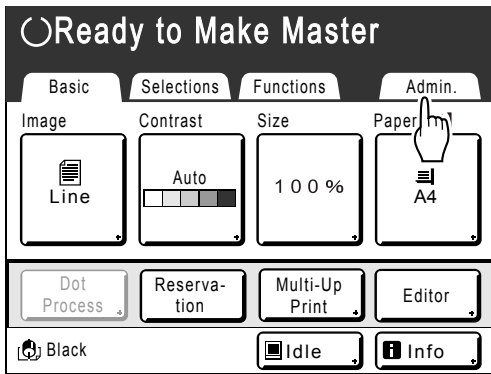

2 Touch [OK].

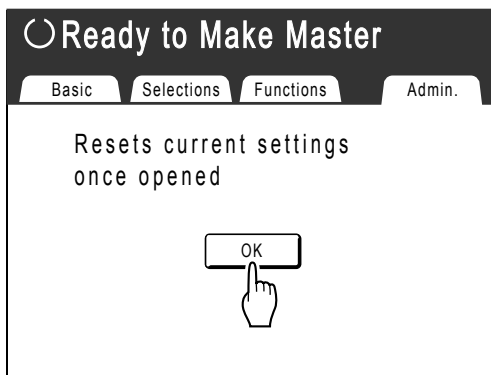

Note:

- When an administrator is registered in User Management, the Recognition Screen is displayed. Operate the screen to log in as the administrator. If already identified as the administrator, the Recognition Screen will not be displayed. Users other than administrator are prohibited.

◆ When “Recognized by” is set to “PIN code”

Input the administrator’s PIN code using the Print Quantity Keys and touch [OK].

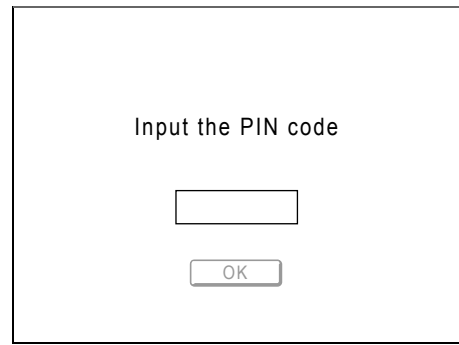

◆ When “Recognized by” is set to “USB Flash Drive”

Connect the administrator’s registered USB Flash Drive to the USB slot.

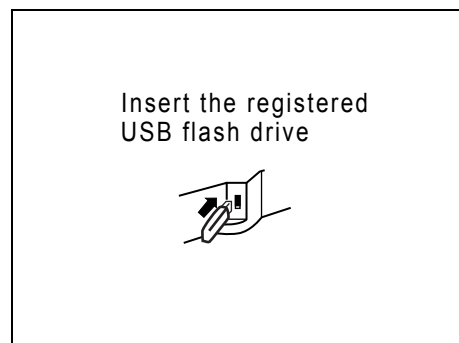

The Admin. screen is displayed once access has been identified.

3 Select a function to modify.

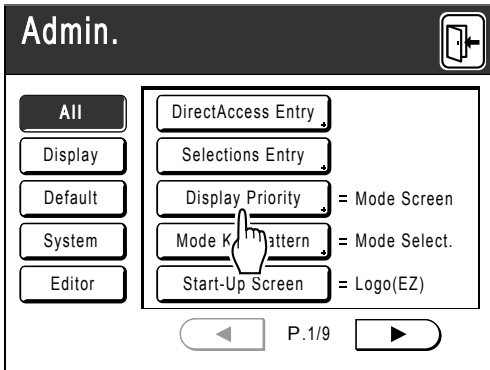

Display Access Buttons

Display Access Buttons allow for quick selection of desired functions by displaying only relevant groups of function buttons.

[All]: All Functions

[Display]: Functions related to Screen Display

[Default]: Basic Operational Functions

[System]: Functions affecting the entire System

[Editor]: Functions related to Editor

4 Change settings.

Some functions have their own Setup screens, some don't. There are several styles for setting values. Following samples demonstrate different value setting styles.

◆ No additional Setup Screen

(2 or more options to choose from)

Touch the function name button to change the value displayed to the right.

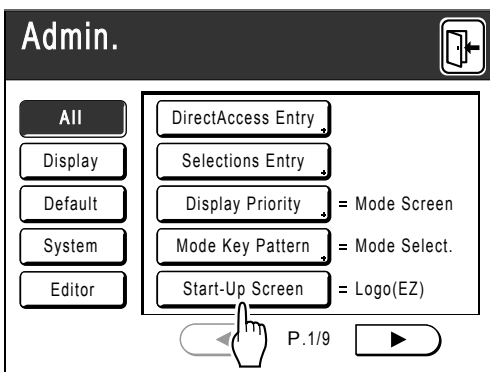

Once the settings have been changed, continue on to step 6.

◆ Additional Setup Screen Available

Button Style

Choosing a button makes it the default.

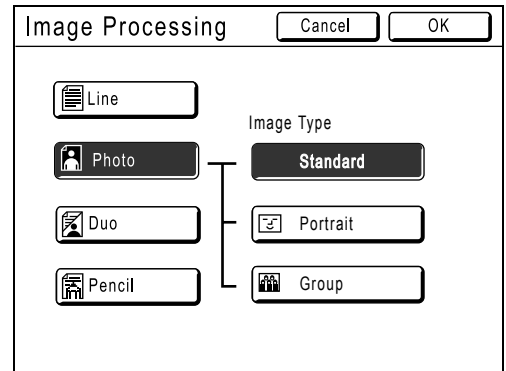

◆ Additional Setup Screen Available

Numeric Value Style

Touch ▲ ▼ to increase/decrease value. Numbers may be entered using the Print Quantity Keys.

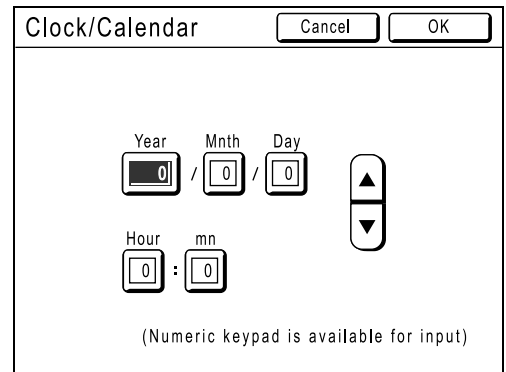

◆ Additional Setup Screen Available

Multi Level Entry Style

Select a button, then set its values either by touching more buttons or entering a value numerically.

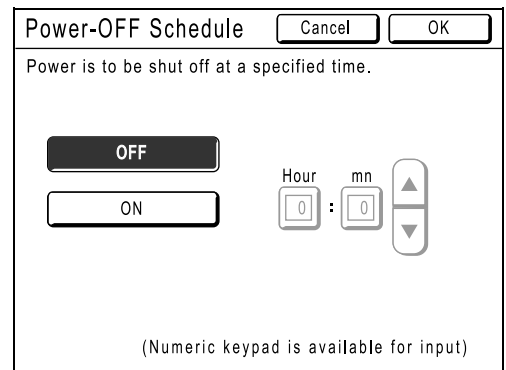

The following screen appears.

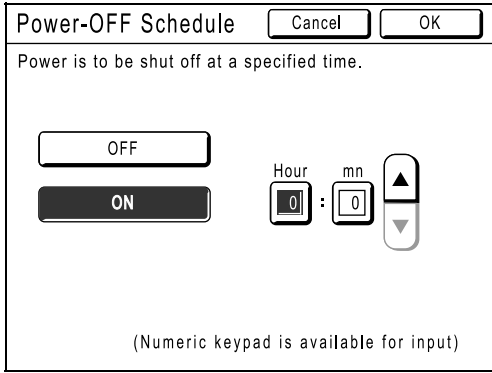

Touch **[ON]** to display more options on the right.

◆ **Additional Setup Screen Available**

Text Input Type

Input the name after touching the button of the name to change.

Touch the button and the Rename screen appears.

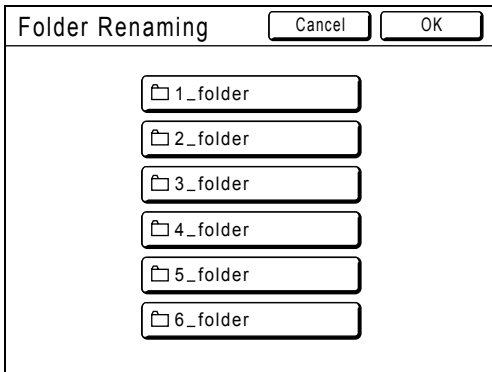

The following screen appears.

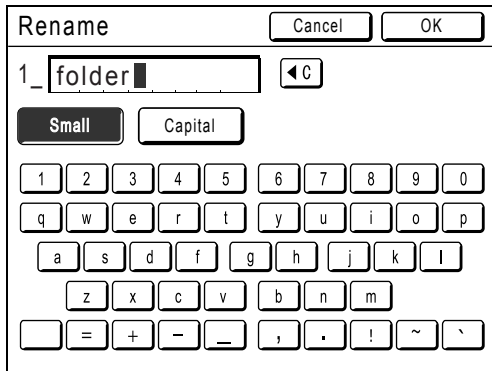

Touch the character buttons to enter text. Change capitalization by selecting the **[Small]** or **[Capital]** button.

☞ p.133

5 Touch [OK].

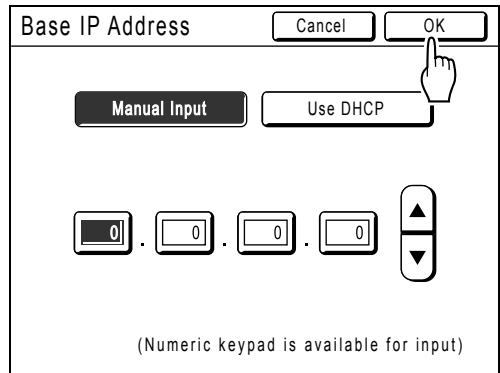

Skip to step 6 if there is no additional setup screen.

Note:

- Touch **[Cancel]** to cancel the changes and return to the Admin. screen.
- The selected value is displayed to the right of the button (for most functions).

6 Touch [Home].

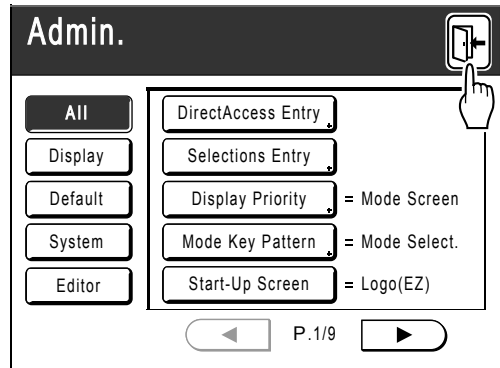

Returns to the original Basic Screen.

Setting Up Direct Access Area and Selections Tab

[Direct Access Entry] [Selections Entry]

Frequently-accessed functions for each mode can be placed on “Direct Access” area in the Basic Screen, or on “Selections” screen.

This allows quick changes and direct access to each function's Setup screens, eliminating the need to search from a long list of functions.

Each mode (Master Making/Print/Scanning) is capable of storing its own unique settings.

Basic Screen	Master Make	Print	Scanning
Direct Access	4	4	4
Selections	9	9	-

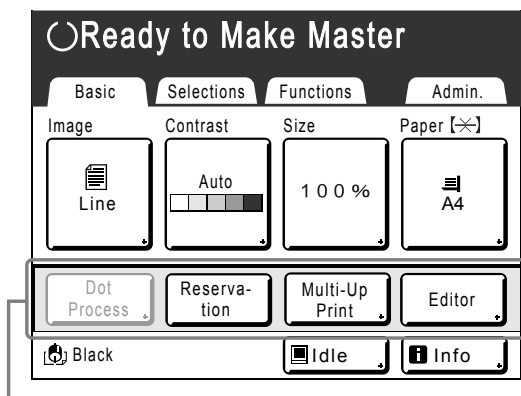

Direct Access Area

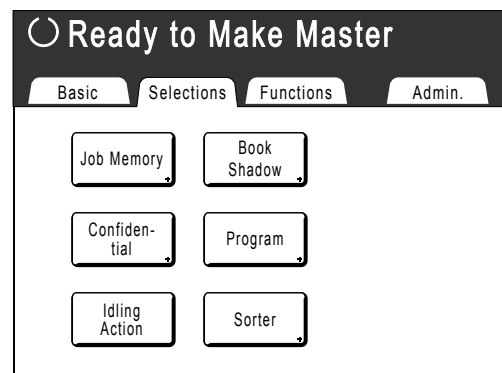

Selections Screen

Note:

- Choose functions that are relevant to each mode.
- The machine comes with factory default “Direct Access” area and “Selections” screen entries, which can be changed.
- Any functions available in the “Functions” screen can be selected.
- Optional attachment is automatically added to the “Direct Access” area and “Selections” tab if a space is available for another button.
- When the Management Level is set to “High/Full Management”, each user can set the functions displayed in the Direct Access Area (My Direct Access). See, [p.158](#).

In the following steps, the “Direct Access” area configuration screen is shown in the upper-left, and the “Selections” configuration screen is shown in the bottom-right. When both screens are the same, only one image will be shown.

1 Touch [DirectAccess Entry] or [Selections Entry] on the Admin. screen.

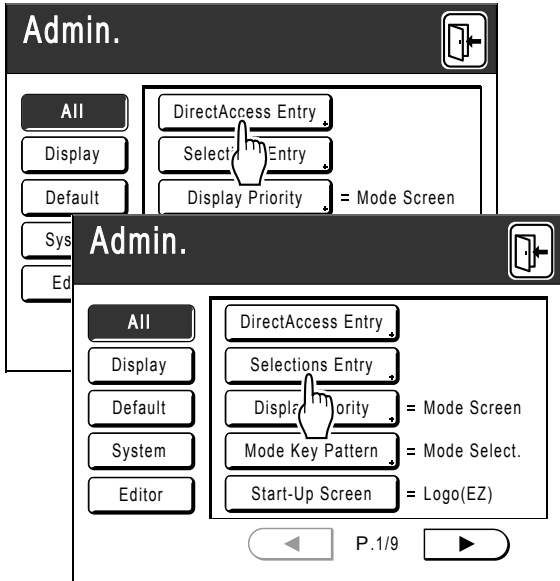

2 Select a mode tab to store new buttons.

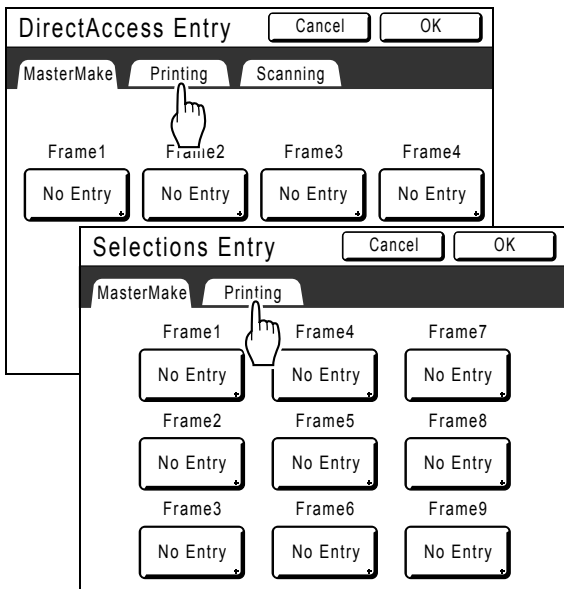

3 Select a button to assign a function.

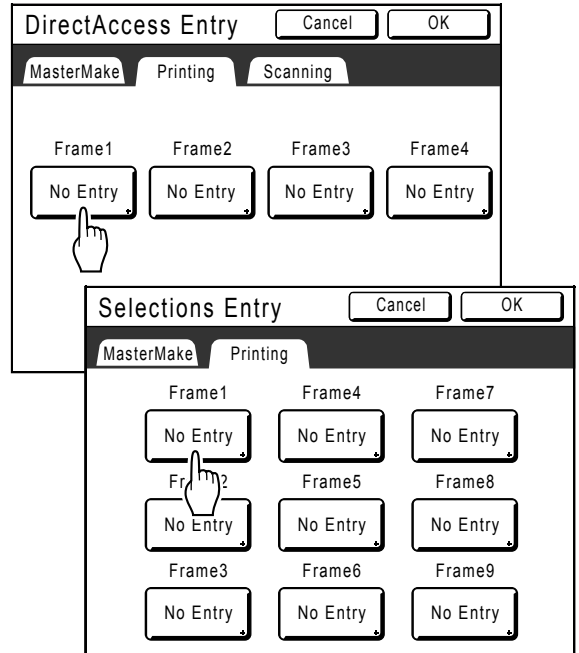

If the button has a function already assigned to it, the newly selected function will overwrite the previous function.

4 Select a function to assign.

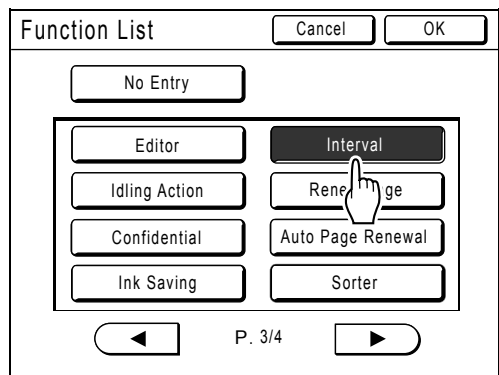

Note:

- Touch ◀ or ▶ to display more functions if necessary.
- To remove a function that is accidentally assigned, touch **[No Entry]**.
- Functions already assigned are grayed-out and are not available.
- Some functions display only when optional devices are installed.

5 Touch [OK].

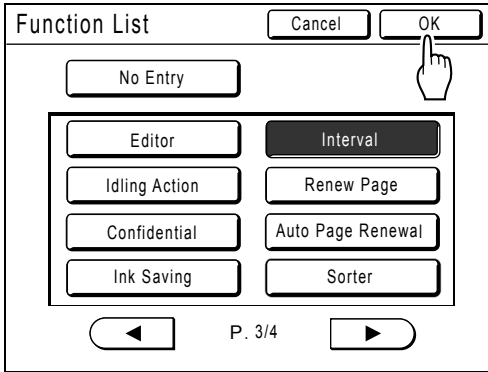

Returns to DirectAccess Entry screen or Selections Entry screen. The selected functions are added.
To add more functions, or to replace a button with another function, repeat steps 2 to 5.

6 Touch [OK].

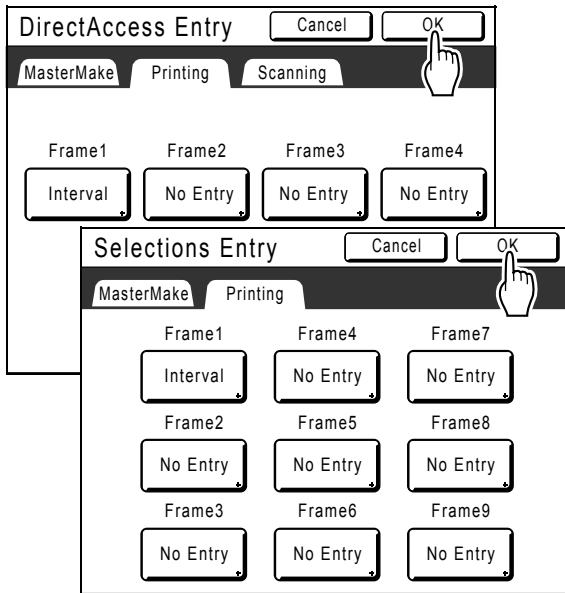

Returns to the Admin. screen. "Direct Access" area or "Selections" screen is updated.

7 Touch .

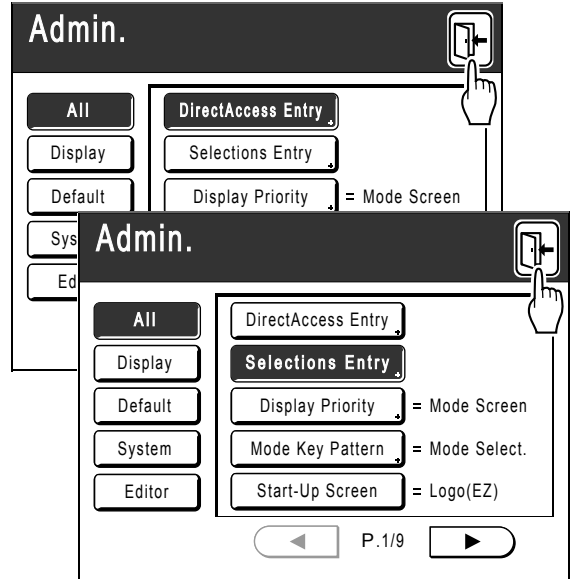

Returns to the Master Making Basic Screen or Print Basic Screen.

Registering a Custom Paper Size

[Custom Paper Entry]

Non-standard paper sizes must be pre-entered into memory. Once a paper size is stored into memory, it can be retrieved with the **[Paper]** button.

Up to 30 different sizes may be entered. Previously stored sizes can be modified or deleted.

Important!:

- Custom paper sizes must be entered. Failure to do so may result in incorrect scanning.

Entering sizes and changing names

1 Touch **[Admin.]** on the Basic Screen for each mode.

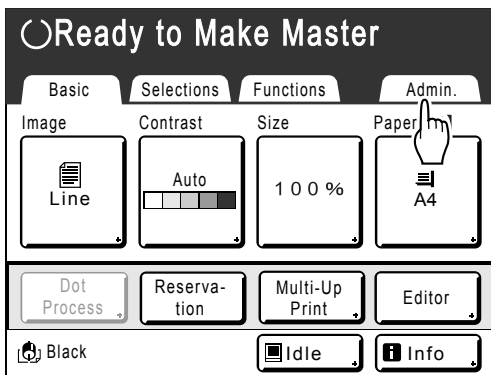

2 Touch **[OK]**.

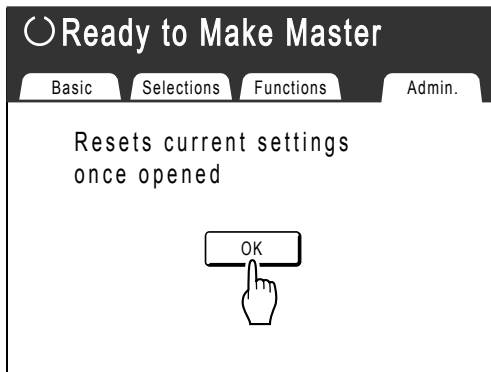

If the Recognition Screen is displayed, follow the message on the screen. See step 2 in "Customizing the Default Settings". (p.168)

3 Touch **[System]** or **[>]** to display **[Custom Paper Entry]** on the screen.

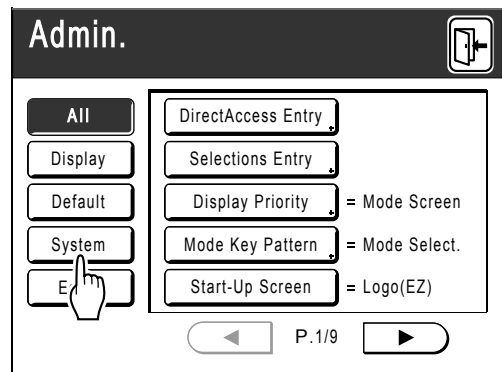

4 Touch **[Custom Paper Entry]**.

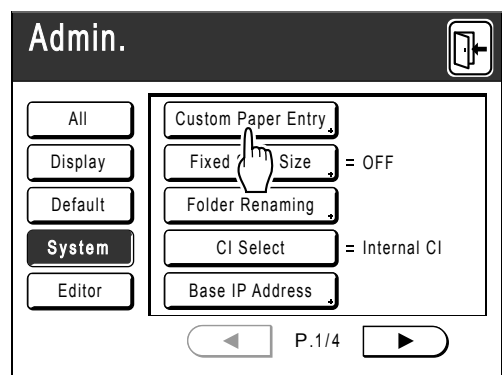

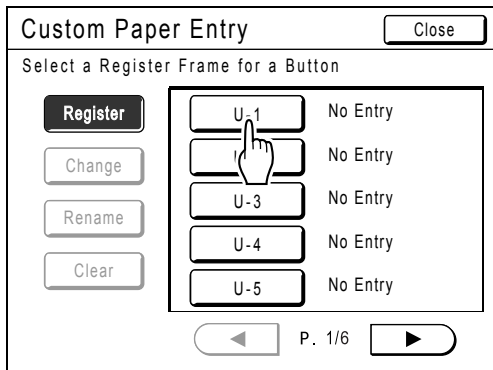

5 Touch an unused button.

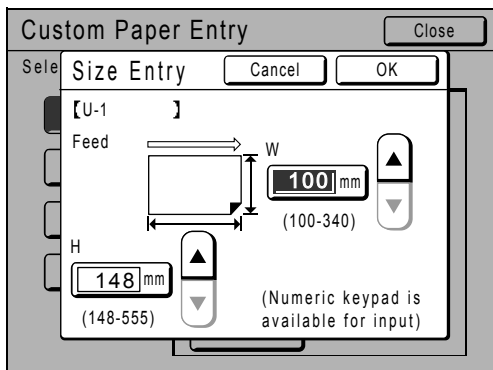

Unused buttons are displayed with a solid line. Used buttons are grayed-out and are not available.

6 Enter the paper size.



Facing towards the paper feeding direction (into Paper Feed Tray), enter W (width) and H (height). Touch either  , or use Print Quantity Keys.

7 Touch [OK].

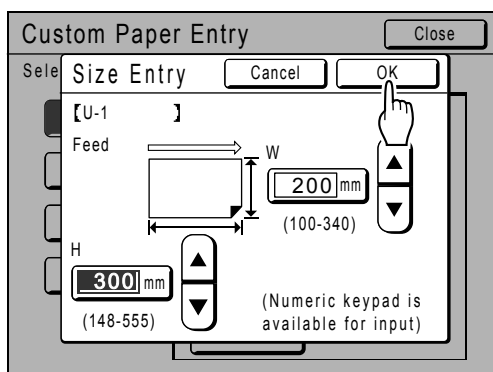

Rename as necessary.

Touch **[Close]** to skip renaming the size.

8 Touch [Rename].

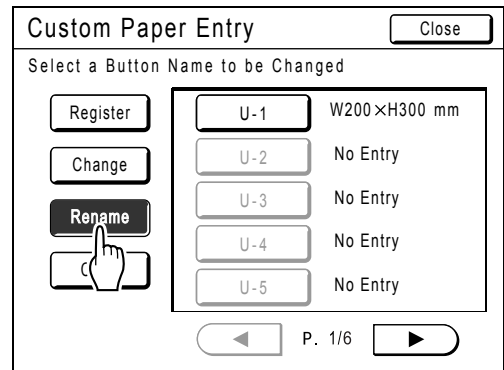

9 Select a button to rename.

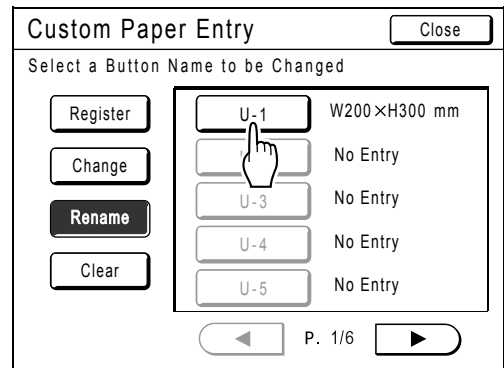

10 Touch the character buttons to enter a new name.

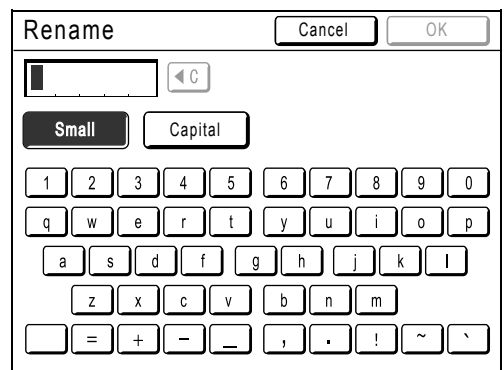

Change capitalization by selecting the **[Small]** or **[Capital]** button.

 p.133

11 Touch [OK] when done.

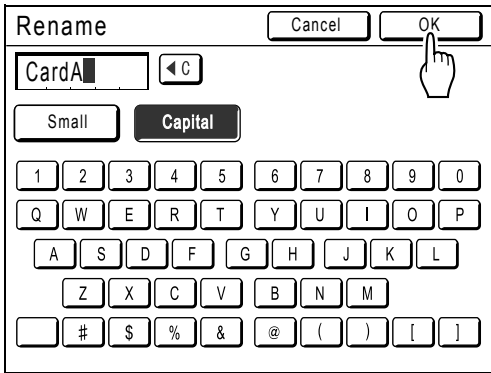

Note:

- To change a name, repeat from step 8.

12 Confirm the name and touch [Close].

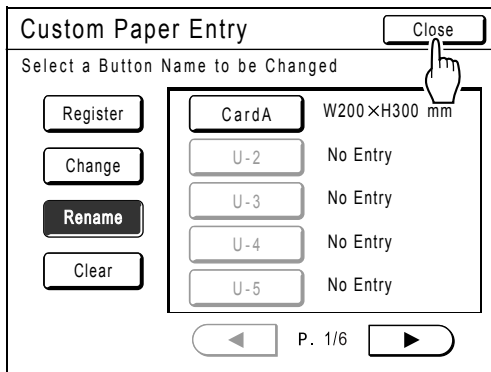

The following screen appears.

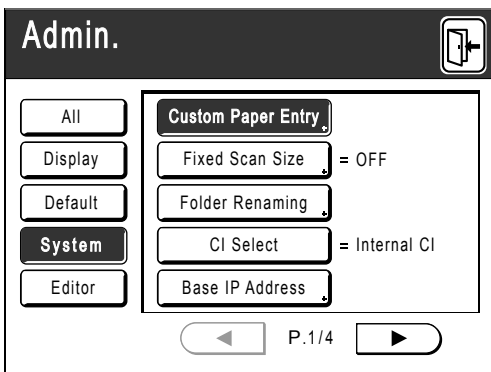

Returns to the Admin. screen. Paper size is updated.

Tip:
Printing on Extended Paper

The machine can print on paper 433 mm-555 mm (17.1"-21.9") long by storing the size as a custom-size.

☞ p.174

When entering a size longer than 433 mm (17.1") on the Custom Paper Entry screen, the paper will be treated as "Extended Paper".

When "Extended Paper" is selected on the Paper Size screen, the machine switches into "Extended Paper" mode.

Important!:

- Some Extended Paper may fail to pass through the machine due to its paper characteristics, or may get smudged with ink due to its image positioning. Consult your dealer (or authorized service representative) for advice.

"Extended Paper" Mode

- When the machine is on "Extended Paper" mode, it is indicated in the message area as either "Ready to Make Master <Ext.Paper>" or "Ready to Print <Ext.Paper>".
- On "Extended Paper" mode, the machine can print papers measuring 433 mm-555 mm (17.1"-21.9") lengthwise from top to bottom facing the paper feed direction. However, maximum printing area and top/bottom Print Positioning range remains as usual.
☞ p.18
☞ p.90
- Print timing and speed is different on "Extended Paper" mode in comparison to normal printing. This is to be expected, so do not be alarmed.
- Contact your dealer (or authorized service representative) for suggestions about placing paper on the Paper Feed Tray and the Paper Receiving Tray when on "Extended Paper" mode.

Clearing a Custom Paper Size

- 1 Touch [Custom Paper Entry] on the Admin. screen.

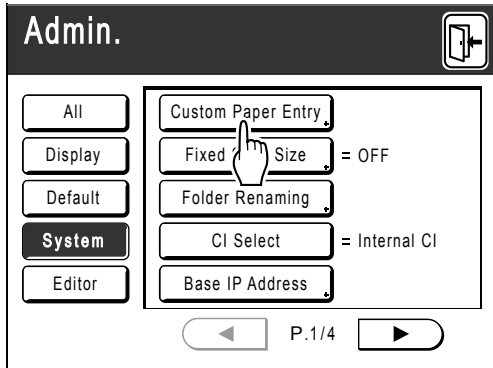

- 2 Touch [Clear].

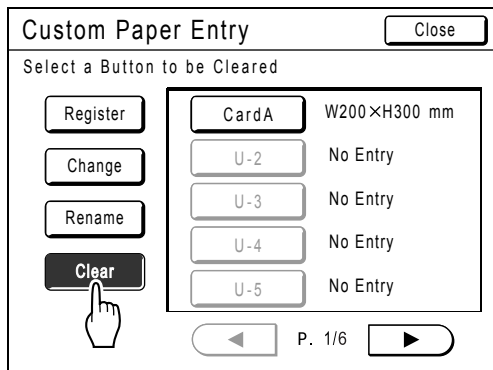

- 3 Select the paper size to clear.

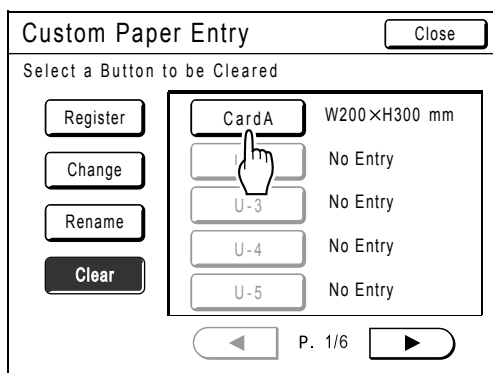

- 4 Touch [OK].

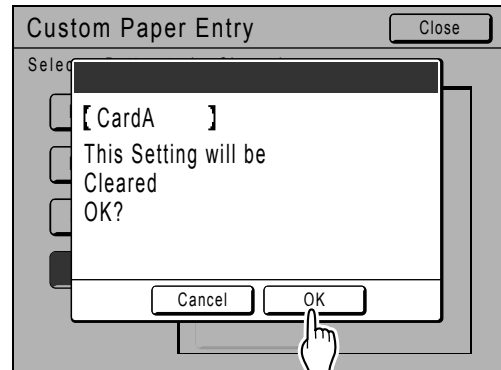

Returns to the Custom Paper Entry screen. The selected paper size is cleared.

- 5 Touch [Close].

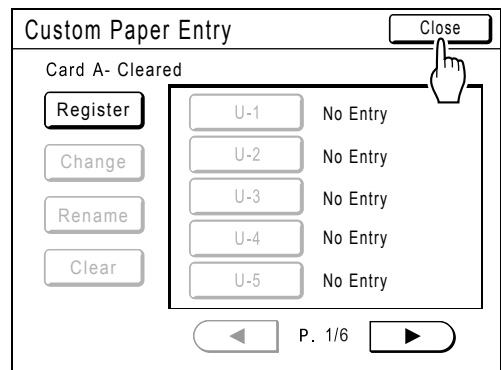

The following screen appears.

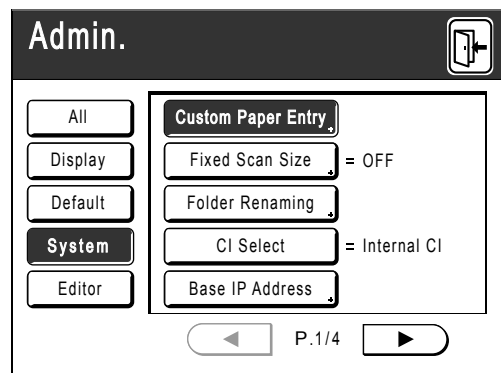

Returns to the Admin. screen. Paper size is updated.

Keeping Masters Secure After Printing

After printing is completed, the master remains on the Print Drum (Cylinder). To protect confidential documents from unauthorized duplication, use the Confidential feature to discard the master after printing. (i.e. “Confidential” function) Used masters are held in the Master Disposal Box. The machine is equipped with a protection function to prevent the master from being removed from the Master Disposal Box and leaked by any ill-intended third party.

“Protect” Setting

When the “Protect” setting is ON:

- When printing is complete, the “Confidential” function is activated to show the message to discard the master remaining on the Print Drum (Cylinder).
- The Master Disposal Box is locked and cannot be removed while the machine is standby. (However, the Master Disposal Box can be unlocked and removed if the master jams in the Disposal Unit or if the Master Disposal Box becomes full.)

Locking the Master Disposal Box

To prevent any leak of master documents after printing, the Master Disposal Box can be locked with a padlock so that no-one apart from the administrator of the machine can remove it. (Purchase an ordinary padlock whose loop will fit through the hole, which is 7 mm (1/4”) wide.)

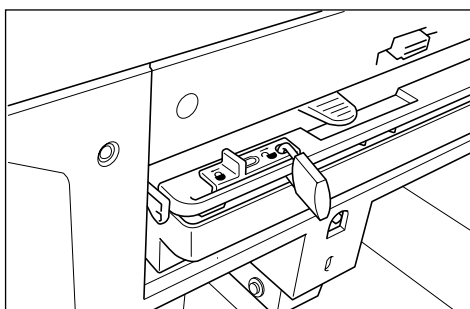

Status of Protect functions and restrictions

Status of [Protect] functions	Restrictions
Protect: OFF Padlock: No	No restrictions on printer access *1
Protect: ON Padlock: No	“Confidential” message is displayed Master Disposal Box is locked *2
Protect: OFF Padlock: Locked	No “Confidential” message is displayed Nobody but the administrator can dispose of the master.
Protect: ON Padlock: Locked	“Confidential” message is displayed Nobody but the administrator can dispose of the master.

*1 The ordinary “Confidential” function is available.

*2 The lock is released if a master jams in the Disposal Unit or if the Master Disposal Box becomes full.

Preventing Leaks of Masters After Creation or Disposal [Protect]

Turning the Protect Setting ON

1 Touch [Admin.] on the Basic Screen for each mode.

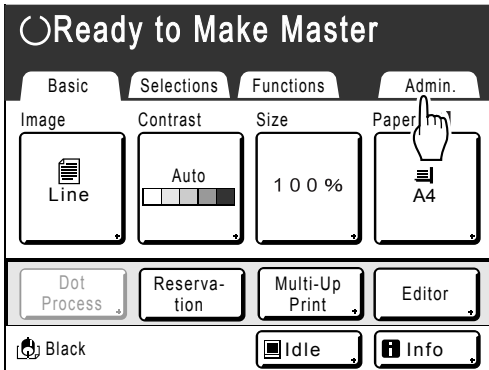

2 Touch [OK].

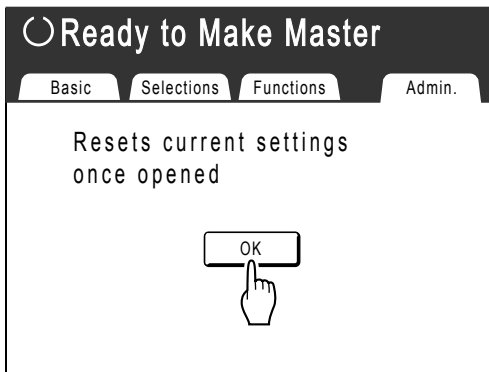

If the Recognition Screen is displayed, follow the message on the screen. See step 2 in "Customizing the Default Settings". (p.168)

3 Touch [Protect].

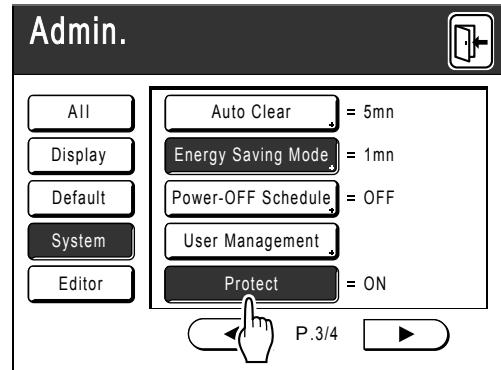

"Protect" is turned ON.

Note:

- If "Protect" is ON, "Energy Saving Mode" (Auto Sleep) is activated automatically.
- If "Protect" is ON, [Renew Page] is grayed-out and is not available.

◆ If "Protect" is ON:

The following screen is displayed after printing.

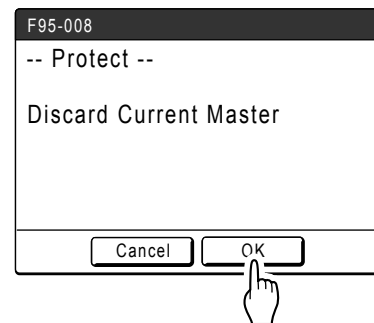



Touch [OK] or [Cancel].

[OK]: Discards the master remaining on the Print Drum (Cylinder).

[Cancel]: Choose this when you do not wish to discard the master or wish to print further copies.

Note:

- The "-- Protect -- Discard Current Master" message is also displayed when printing from computer data on a PC.
- If you select **[Cancel]** while the "Protect" setting is active, the "-- Protect -- Discard Current Master" message appears each time you press the  key or the  key.
- The screen shows the message below when:
 - setting the Print Drum (Cylinder) that has been removed without the "Confidential" operation, or
 - the machine goes into the sleep mode after a certain period of time has passed after the confirmation message was displayed, and then the sleep mode is canceled (or the power is turned ON).

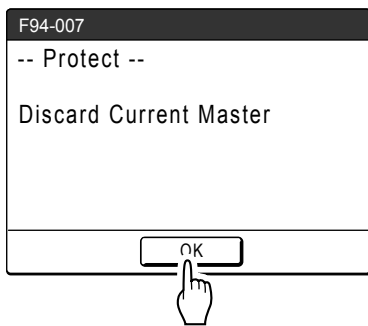

Touch **[OK]** to discard the master remaining on the Print Drum (Cylinder).

Storing Original Data and Use Method

The machine can store original data. (To use this function, an optional Document Storage Card DM-128CF or USB Flash Drive is required.)

Stored original data can be repeatedly retrieved for printing.

There are two methods of storing original data: "Storage Memory" and "USB Flash Drive". "Storage Memory" allows you to store original data on the internal optional Document Storage Card DM-128CF of the printing machine. "USB Flash Drive" allows you to store original data in a USB Flash Drive. Both methods can store original data as follows.

- Storing data from a hard-copy original after scanning from the scanner of the printer.
- Storing original data created on a computer.

The methods of storing data from a hard-copy original and printing the stored original data are explained here. Details on how to store the data created on a computer, see the "RISO Printer Driver User's Guide".

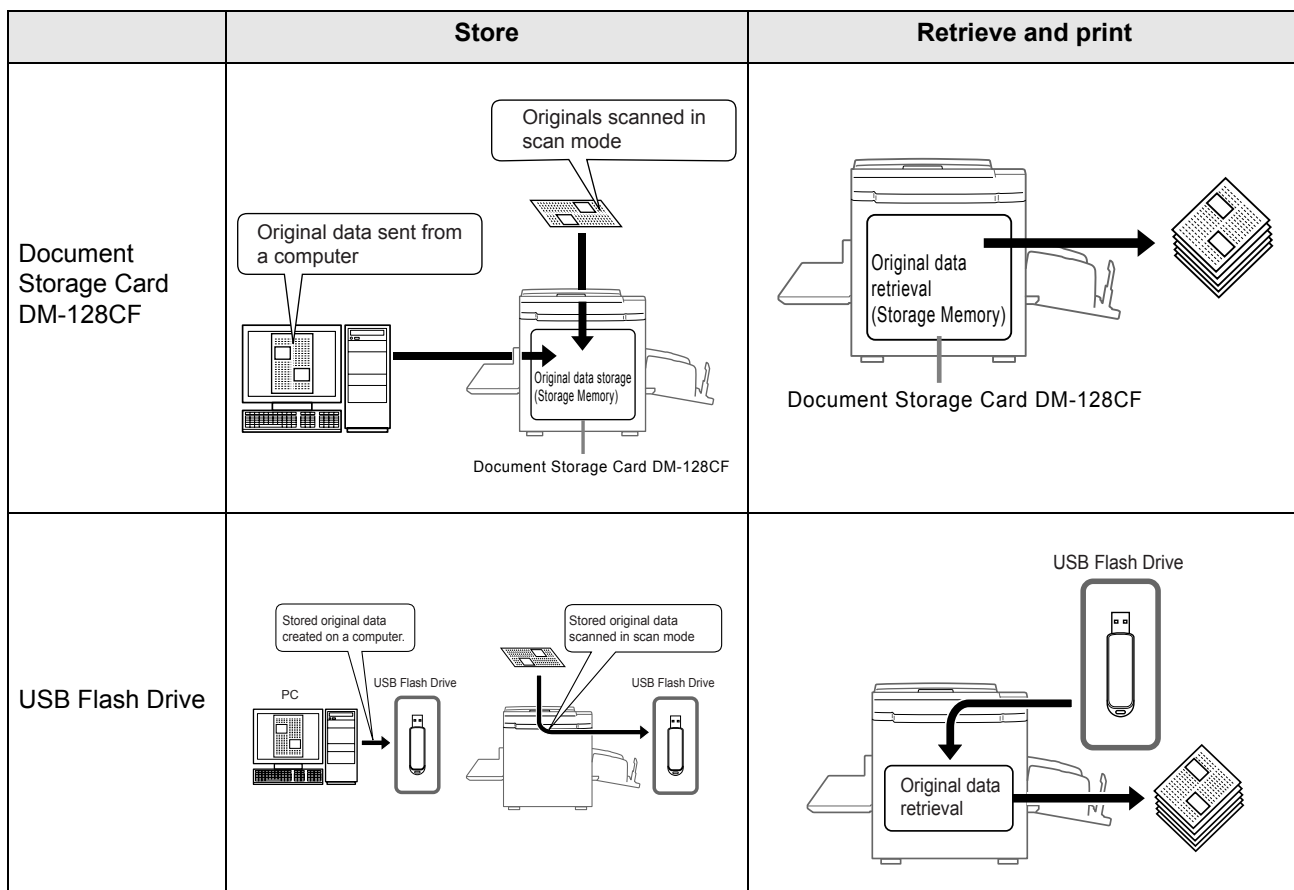

- The following operations are available with data stored in “Storage Memory” or “USB Flash Drive”.
 - Stored original data can be repeatedly retrieved for printing.
 - If the storage data contains multiple pages, you can choose to output only odd or even pages, or indicate the specific pages to print using “Output”.
☞ p.192
 - The storage data also can be overlaid onto a hard-copy original and printed.
☞ p.195
- All users of this machine can use the 6 folders in “Storage Memory”. It is convenient to store and use the data in common with others.
- 6 folders are created in each “USB Flash Drive”. Use the folders as needed, such as when selecting a folder for storing any specified data.

Important!:

- We cannot guarantee storage data or USB Flash Drive data against loss caused by accidents or unforeseen events. We recommend that you use your computer to make back-up copies of any important documents.

Note:

- You can easily delete unnecessary stored data when remaining free space of the optional Document Storage Card DM-128CF or USB Flash Drive is limited. The free space is displayed in the Storage Selection screen or USB Job List screen.
☞ p.192
- Folder names of the optional Document Storage Card DM-128CF can be changed on the Admin. screen.
☞ p.164
- To change folder names of the USB Flash Drives, use the “RISO Utility Software” (RISO USB PRINT MANAGER) included on the provided software CD-ROM. (If you change folder names by Explorer, they will not be recognized by the machine.) ☞ “RISO Utility Software User’s Guide” (CD-ROM)
- You can change the order of the storage data and USB Flash Drive data.
☞ p.194

Converting Hard-copies into Stored Data (Scan Mode)

Scan mode is a function that allows you to scan a hard-copy original with the machine's scanner to save as storage data or USB Flash Drive data.

You can repeatedly retrieve and print previously scanned and stored original data. This saves you the trouble of rescanning documents when repeatedly printing the same materials.

☞ p.189

This function also prevents documents from getting lost or damaged over time.

Note:

- You can easily delete unnecessary stored data when remaining free space of the optional Document Storage Card DM-128CF or USB Flash Drive is limited.

☞ p.192

The following functions can be used in scan mode: See the explanation of each function for more details.

- Image (☞ p.52)
- Contrast (☞ p.54)
- Size (enlargement/reduction) (☞ p.55)
- Dot Process (☞ p.62)
- 2 Up/Multi-Up Print (☞ p.65)
- Book Shadow (☞ p.77)
- Preview (☞ p.83)

The following functions are specific to scan mode.

- Format (☞ p.188)

Scanning an Original

1 Place the original.

See step 4 in "Printing from a Paper Document or Book" (☞ p.38).

2 Select a scan mode.

See ☞ p.24 for information about selecting a scan mode.

After selecting the Scan mode and if the following "Page Size" screen is displayed, select the page size (original size) and touch **[OK]**.

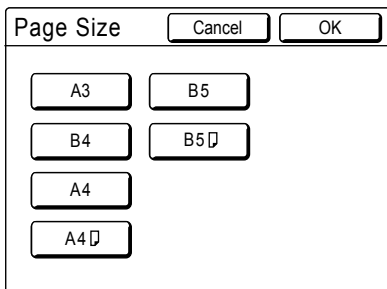

The Scan Basic Screen is displayed.

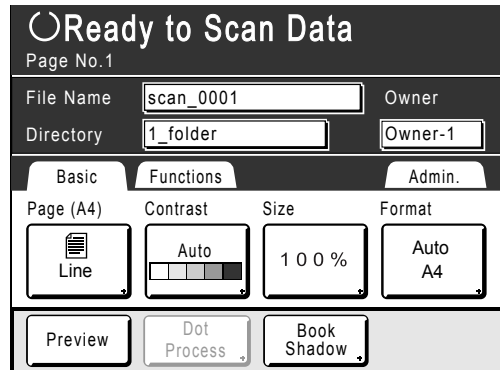

3 Setting data information.

Sets the file name, directory and owner name.

☞ p.186

4 Setting required functions.

Set the required functions for scanning the original.

Note:

- You can check scanned data instantly by enabling the “Preview” function. You can also use this function to check data before saving.
 ↗ p.83
- See ↗ p.184 for the functions that can be set.

Important!:

- Set “Format” when scanning custom-sized originals.
 ↗ p.188

5 Press the key.

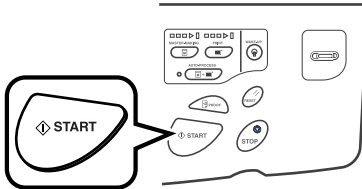

The scan starts.

Note:

- After scanning the original, a preview shows on the display if “Preview” is set.

6 Repeat steps 2, 4 and 5 if the original has multiple pages.

Note:

- If multiple originals were placed on the ADF unit (Option), all originals will be scanned at the same settings.

7 Touch .

Once the original to be saved as one set of data is scanned, touch .

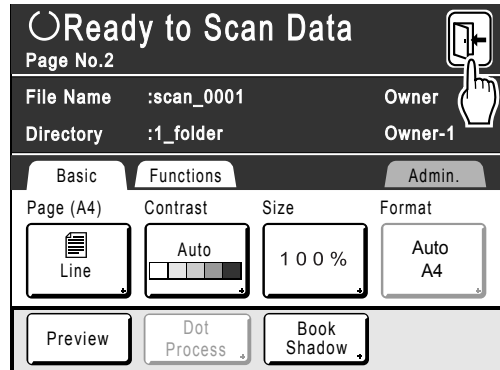

A confirmation screen appears.

8 Touch [Yes].

The data is saved.

Note:

- Press the  key to exit scan mode.

Setting Data Information

Settings for the data to be scanned and stored are configured on the Scan Basic Screen.

1 Select a scan mode.

See p.24 for information about selecting a scan mode.

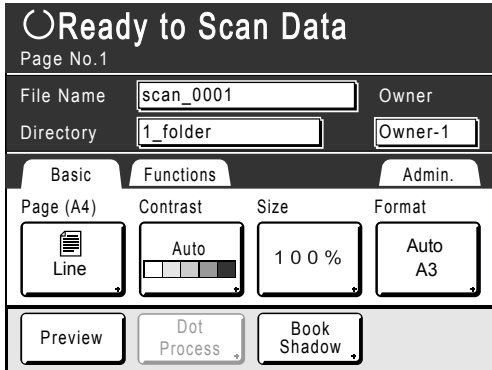

The file name, directory and owner name are automatically allocated when scan mode is started, but you can change this preset information if needed.

Note:

- Default settings for the “Directory” folder can be changed in “Admin.” (p.164)

2 Enter a file name.

- 1) Touch the file name input box.

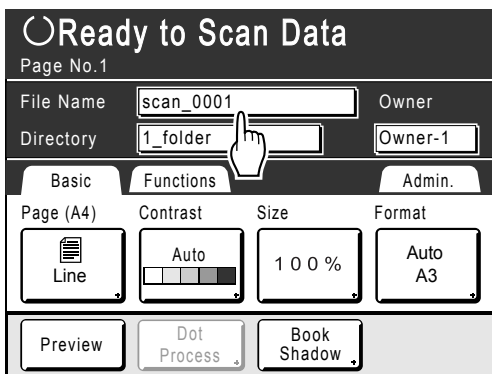

The Rename screen appears.

- 2) Touch the **<C** button to delete the current name.

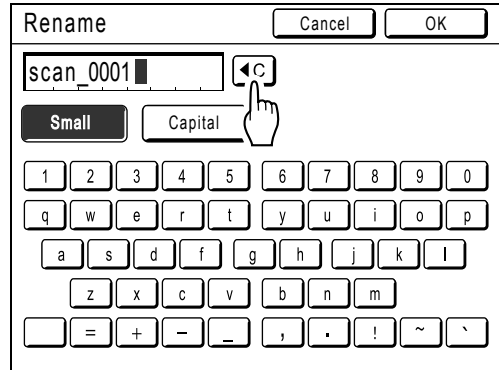

Note:

- You can also press the **C** key to delete.

- 3) Touch the text button and enter the file name one character at a time. Touch the Text Type button to change the display, and look for the text you want to enter. (p.133)
- 4) Touch **[OK]**. The file name is confirmed and the screen returns to the Scan Basic Screen.

3 Specifying a Directory.

When saving in the USB Flash Drive, connect the USB Flash Drive to the USB slot in advance.

- 1) Touch the directory input box.

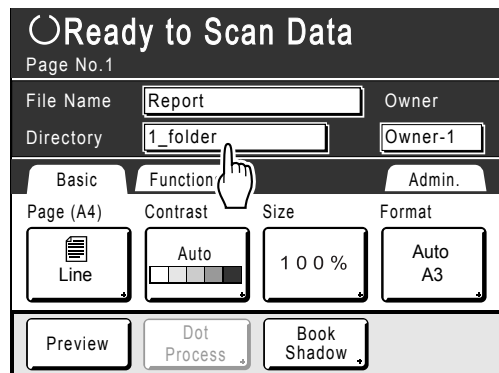

The Directory screen appears.

- 2) Touch **[Storage Memory]** or **[USB Flash Drive]**.

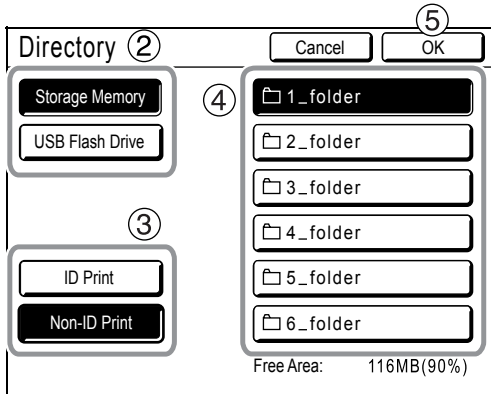

If the USB Flash Drive is not connected, **[USB Flash Drive]** is grayed-out and is not available.

- 3) Touch **[ID Print]** or **[Non-ID Print]**. **[ID Print]** and **[Non-ID Print]** are displayed only when "Management Level" is set to "High/Full Management".
- 4) Touch the folder to save the data.
- 5) Touch **[OK]**. The "Directory" folder is confirmed and the screen returns to the Scan Basic Screen.

Note:

- The folder name of the "Directory" folder of storage data can be changed in "Admin.". (p.164)

4 Specifying an Owner.

- 1) Touch the owner input box.

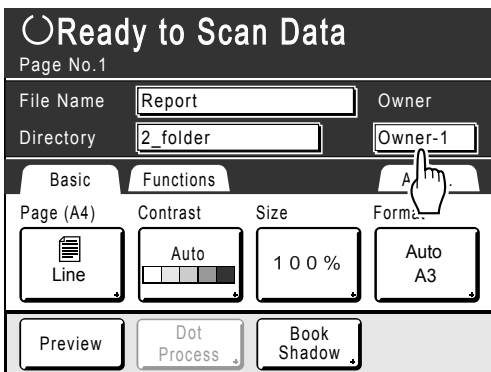

The Owner screen appears.

- 2) Touch the button of the owner to set.

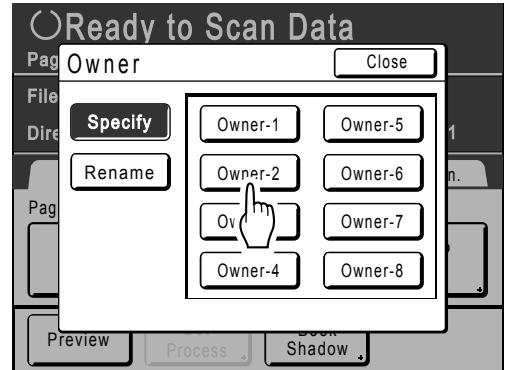

The owner name is confirmed and the screen returns to the Scan Basic Screen.

Tip:
Changing the Owner Name

- 1) Touch **[Rename]** on the Owner screen.

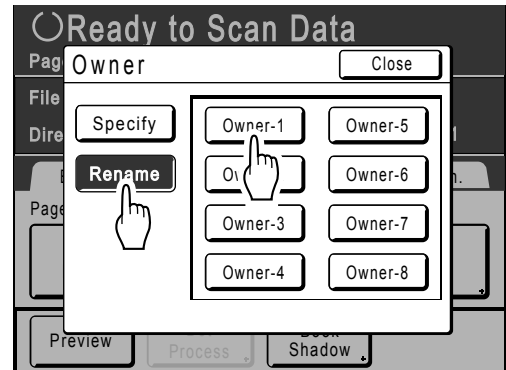

Touch the button of the owner to rename. The Rename screen appears.

- 2) Touch the **[C]** button to delete the current name.
- 3) Enter the Owner name.
- 4) Touch **[OK]**.

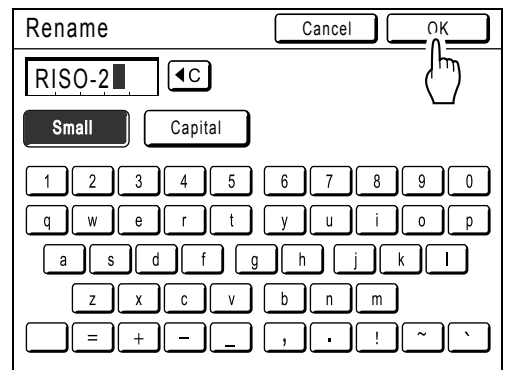

The owner name is confirmed and the screen returns to the Owner screen.

Specifying Stored Size

Specify the size at which to save the scanned original.

It is necessary to set the Format size when:

- you place the originals on the glass platen
- you set the custom-sized originals in the ADF unit (Option)
- you want to save at a size that differs from the size of the original

1 Touch [Format] on the Scan Basic Screen.

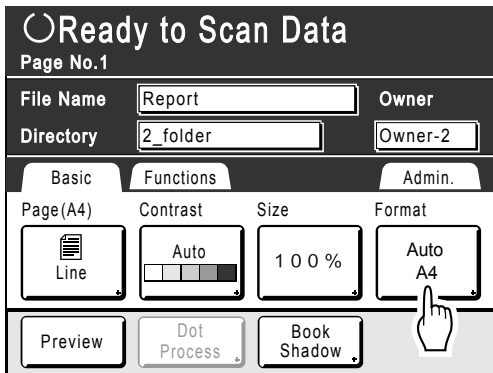

The Format screen appears.

2 Touch the Format size button to be set.

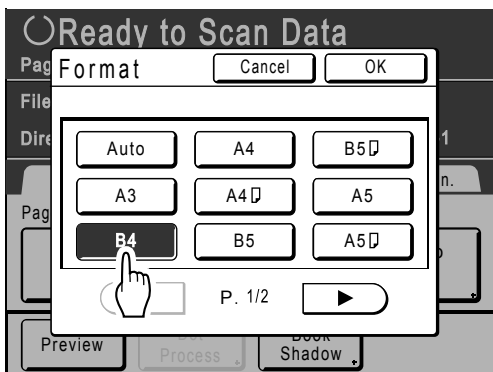

If you select [Auto], the same size as the original will automatically be set.

3 Touch [OK].

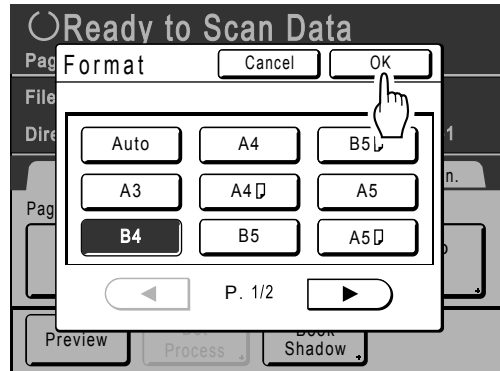

The following screen appears.

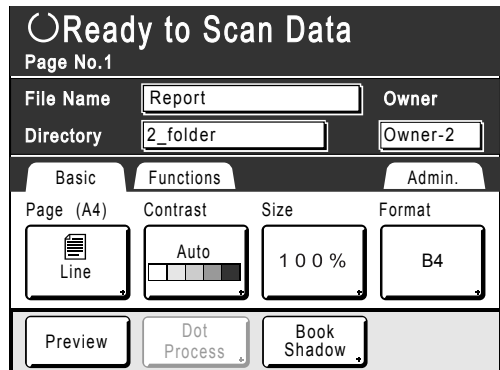

The stored size is confirmed and the screen returns to the Scan Basic Screen.

Note:

- Check the enlarging/reducing when you want to store the data in a paper size other than the original paper size.

Retrieving Stored Data and Printing

[Storage Memory][USB Job List]

Retrieving Stored Data

When retrieving the USB Flash Drive data, connect the USB Flash Drive to the USB slot in advance. For details on how to print USB Flash Drive data, see p.43 “Printing from a Computer Data”.

Note:

- When “User Management” is set up by the administrator, the users will be asked to identify themselves during operations. For details, refer to p.42.
- When “Recognized by” is set to “PIN code” in User Management and the USB Flash Drive is connected while the Basic Screen for each mode is displayed, the USB Job List screen is automatically displayed. See step 4.

1 Touch [Functions] on the Master Making Basic Screen.

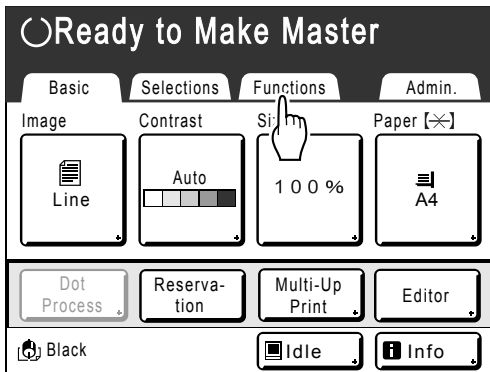

2 Touch [Storage Memory] or [USB Job List].

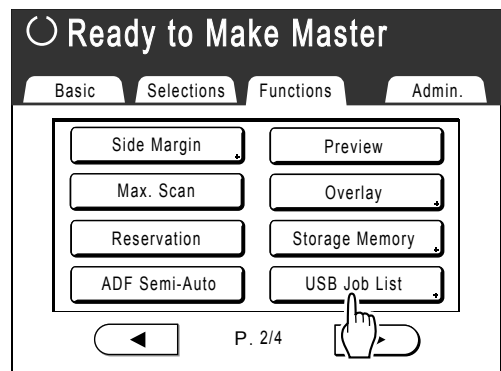
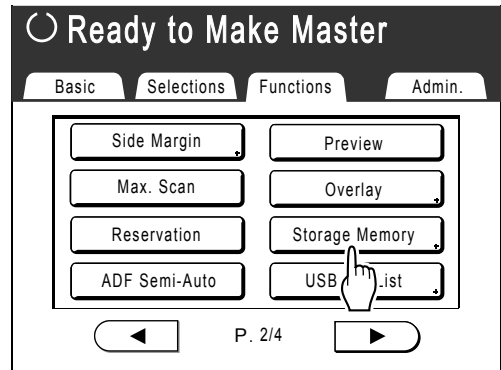

The Storage Selection screen or USB Job List screen (with “Non-ID Print”) is displayed. (The “ID Print Job” button is displayed on the screen.)

3 Select [ID Print Job] or [Non-ID Print].

Note:

- When “Management Level” is set to “Low/ Admin tab only” in User Management, [ID Print Job] will not be displayed.

◆ **When retrieving data set with “ID Print Job”**

Touch [ID Print Job].

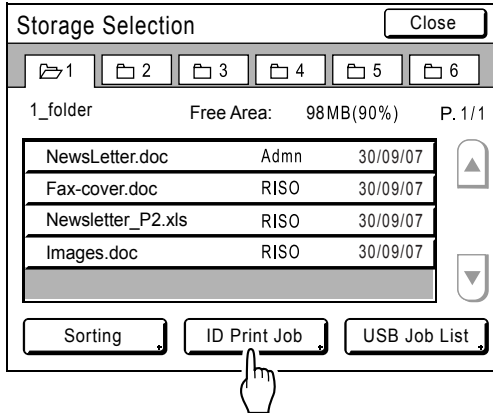

◆ **When retrieving data set with “Non-ID Print”**

When “Non-ID Print” is displayed on the screen, touch “Non-ID Print”.

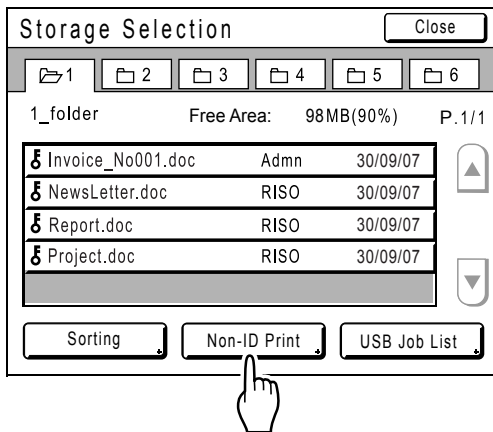

4 Touch the data to print.

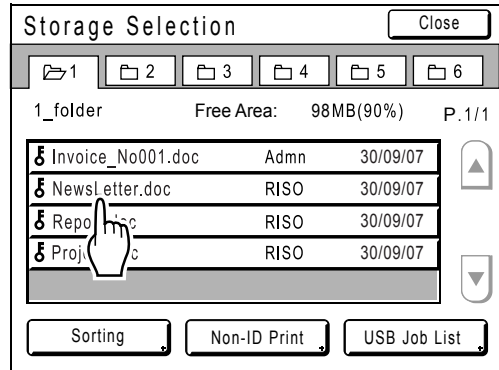

If you are selecting data stored in a different folder, touch that folder's tab.

Note:

- If the stored data is not shown on the screen, touch ▲ or ▼ to display.
- Touching [USB Job List] or [Storage Memory] displayed in the bottom right corner of the screen switches to the Storage Selection screen or USB Job List screen.

5 Confirm the retrieved data.

Use the thumbnail to determine whether the retrieved data is the data desired.

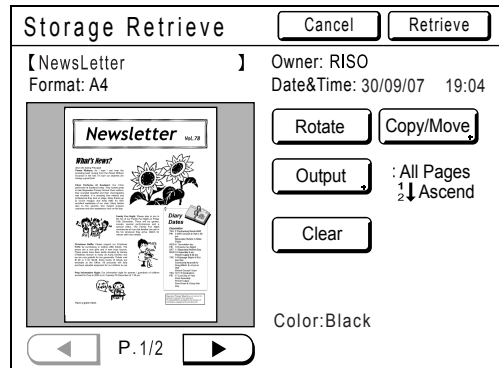

From the Storage (USB Job List) Retrieve screen, you can confirm retrieved data and specify output settings.

See p.192 for operational details.

6 Touch [Retrieve].

The data is retrieved and Storage Mode Basic Screen appears.

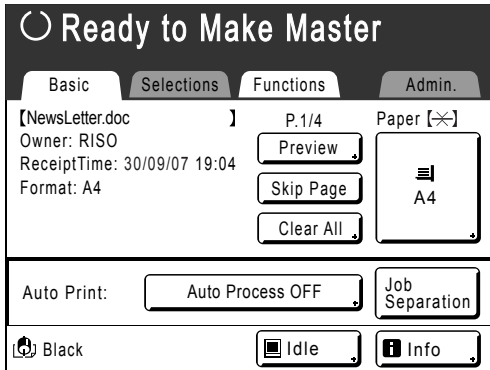

7 Press the key.

A master is made from the data.

After this, follow the same operations for paper documents.

Using the Storage Retrieve Screen/USB Job List Retrieve Screen

Each section of the Storage Retrieve screen/USB Job List Retrieve Screen is shown below. An example of the Storage Retrieve screen is explained here.

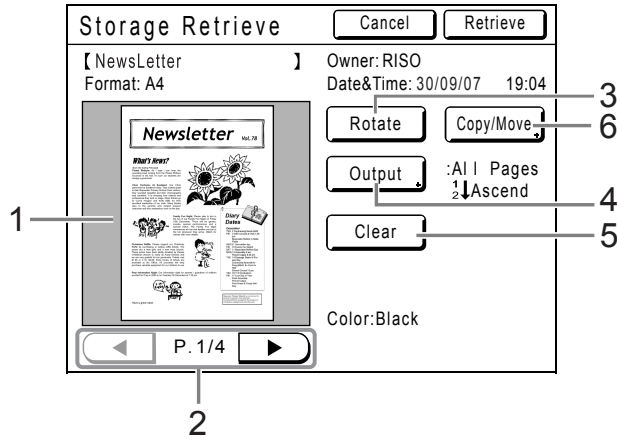

- 1) A thumbnail is displayed for each page.
- 2) If the data contains multiple pages, touch to change page.
- 3) Touch to rotate the storage data 180 degrees and output.
- 4) **Output Range**

If the storage data/USB Flash Drive data consists of multiple pages, you can specify which pages to print. Touch **[Output]** to display the Output screen.

To specify a page range, touch the page input box and touch either or to specify the pages.

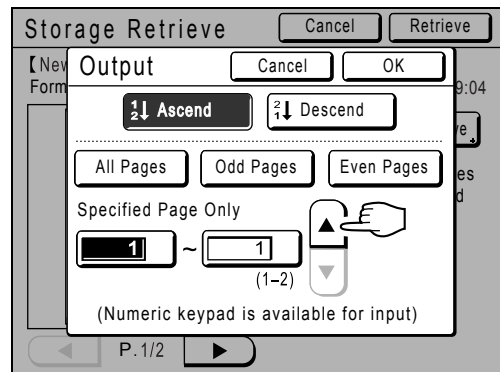

5) Clear

Touch **[Clear]** and a confirmation screen appears. Touch **[OK]** to clear the data.

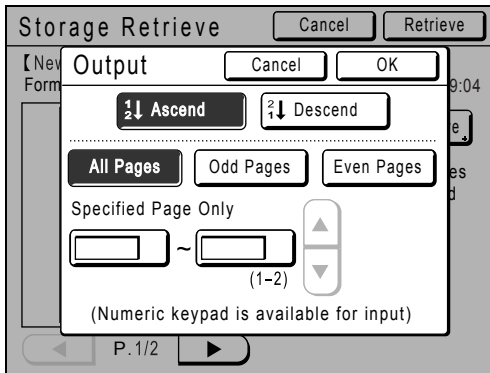

Touch the corresponding buttons to print all pages, only odd pages, or only even pages. You can also specify whether to print the selected pages in **[Ascend]** or **[Descend]** order.

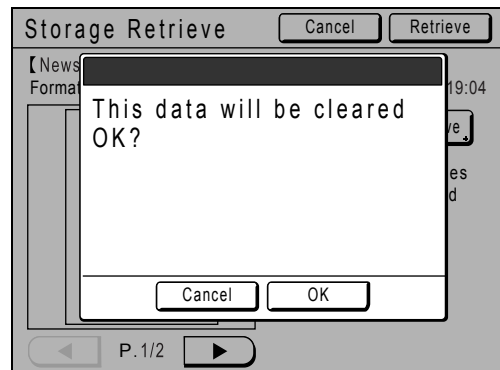

6) Copy/Move

Copy/Move the stored data between the Storage Memory and USB Flash Drive. From the Storage Retrieve screen, copy/move data to the USB Flash Drive. From the USB Job List retrieve screen, copy/move data to the Storage Memory.
For details, see p.197.

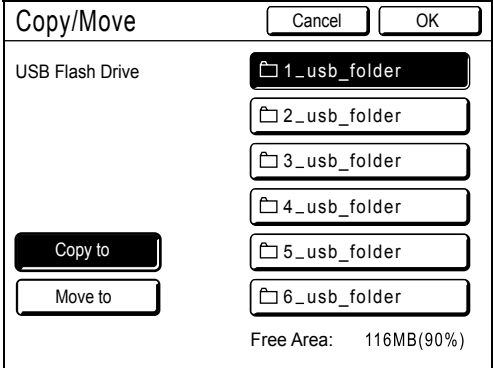

Changing the Data Order

You can change the order of the stored data displayed on the Storage Selection screen/USB Job List screen. An example of the Storage Selection screen is explained here.

Note:

- The factory setting is “Date Descend”.

1 Touch [Sorting].

Note:

- [Sorting] is inactive if there is no storage data/ USB Flash Drive data or only one stored item.

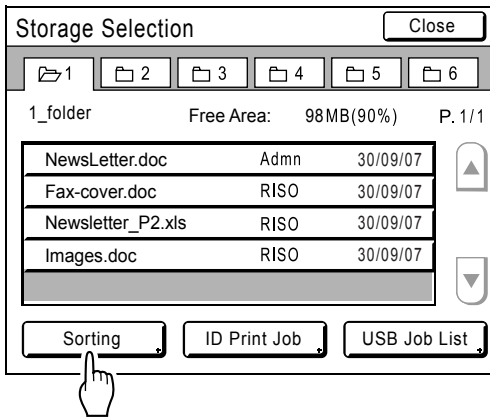

2 On the Sorting screen, touch the button of the order you want.

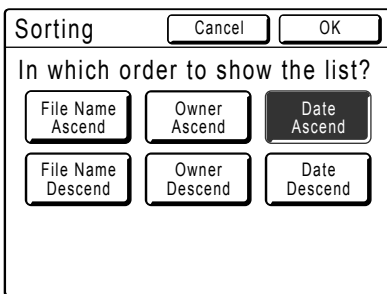

3 Touch [OK].

Returns to the Storage Selection screen (USB Job List screen).

Overlaying Stored Data onto a Print Job

[Overlay]

You can overlay stored data onto a hard-copy original.

For example, this function can be used to overlay a stamp over multiple originals indicating "Sample".

Important!:

- This function cannot be used with the following functions.
 - Ink Saving
 - Top Margin
 - Side Margin
 - Storage Memory ("Overlay" images cannot be stored.)
 - USB Job List ("Overlay" images cannot be stored.)
 - When sending original data from the computer

1 Place an original.

Place the original on Glass Platen or in ADF unit (Option).

See [p.38](#) for information on placing the original.

2 Touch [Functions] on the Master Making Basic Screen.

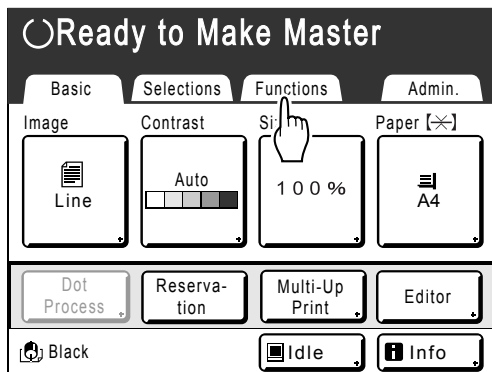

3 Touch [Overlay].

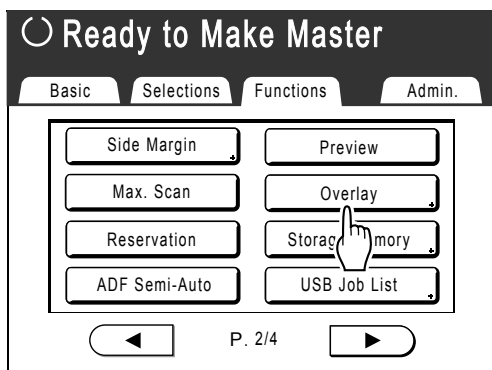

The Storage Selection screen appears.

When overlaying data stored in the USB Flash Drive, connect the USB Flash Drive to the USB slot and touch **[USB Job List]**.

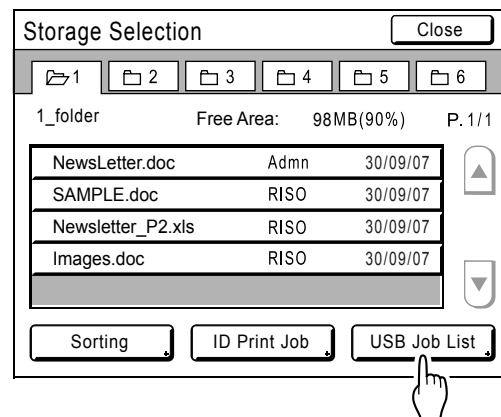

USB Job List screen is displayed.

Important!:

- Do not remove the USB Flash Drive until printing is finished.

4 Select the stored data to overlay.

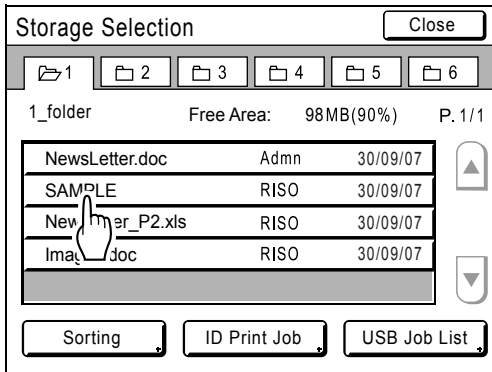

Details on how to select data, see steps 3 and 4 in “Retrieving Stored Data and Printing” (p.190).

5 Confirm the stored data and touch [Retrieve].

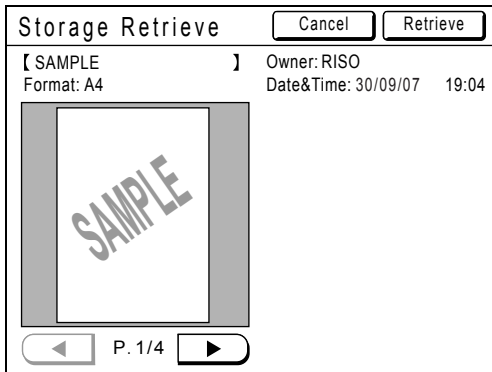

Tip:
Overlaying Stored Data

The stored data overlays at the size it was saved. You cannot enlarge/reduce the size to match the original or paper size.

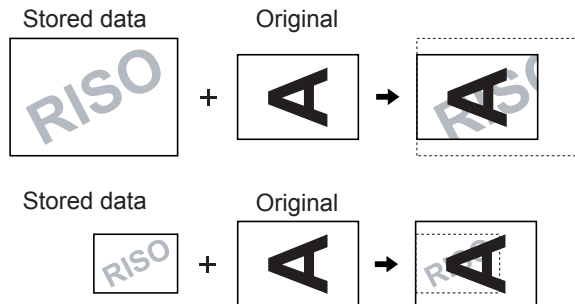

The stored data is overlaid after being centered at the top of the original. You cannot adjust the overlay position.

The following screen appears.

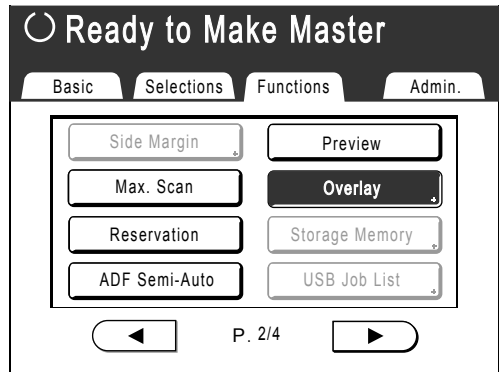

“Overlay” is set and the screen returns to the Functions screen.

6 Print.

For subsequent operations, see step 5 in “Printing from a Paper Document or Book” (p.39).

Copying/Moving Stored Data

Data can be copied or moved between the Storage Memory and USB Flash Drive. This is useful for performing backup or when the remaining free space of the Storage Memory or USB Flash Drive is limited.

Note:

- It is not possible to copy/move data within the Storage Memory or USB Flash Drive.
- The original data stored in the USB Flash Drive can be organized or managed by a computer using the “RISO Utility Software” (RISO USB PRINT MANAGER) included on the provided CD-ROM. For details, see the “RISO Utility Software User’s Guide” (CD-ROM).
- The [ID Print Job] is maintained even if it is copied or moved.

The procedure for copying/moving data from the Storage Memory to the USB Flash Drive is explained here.

1 Confirm that the USB Flash Drive that will store the data is connected.

If the USB Flash Drive is not connected, connect the USB Flash Drive to the USB slot.

2 Touch [Functions] on the Master-Making Basic Screen.

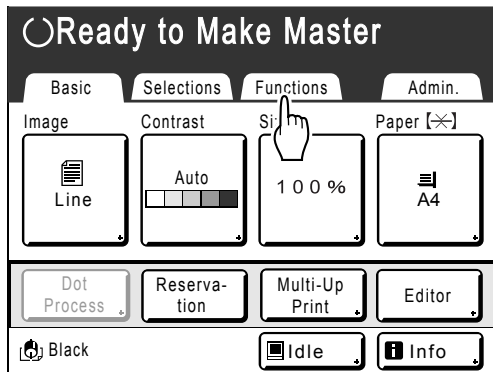

3 Touch [Storage Memory].

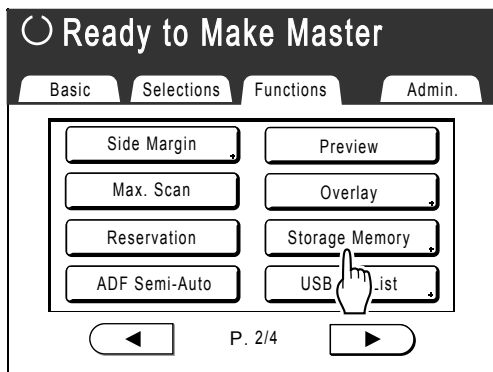

Note:

- When copying/moving the data from the USB Flash Drive to the Storage Memory, touch [USB Job List].

4 Touch the storage data to copy/move.

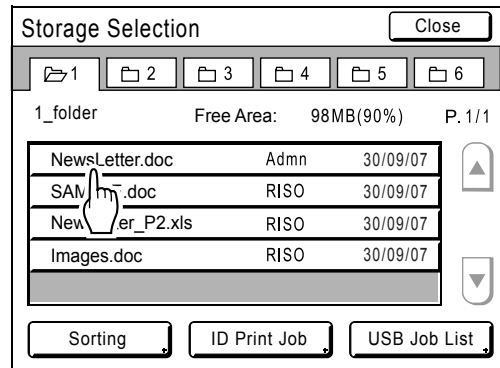

For details on how to select data, see steps 3 and 4 in “Retrieving Stored Data and Printing” p.190.

5 Touch [Copy/Move].

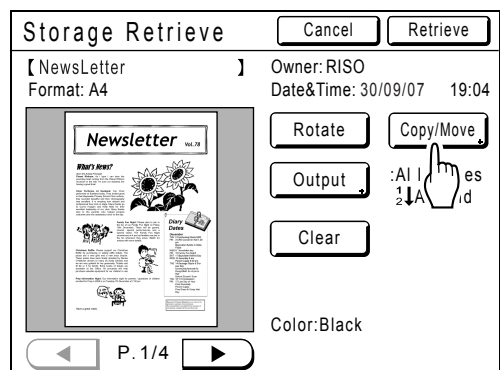

6 Touch [Copy to] or [Move to].

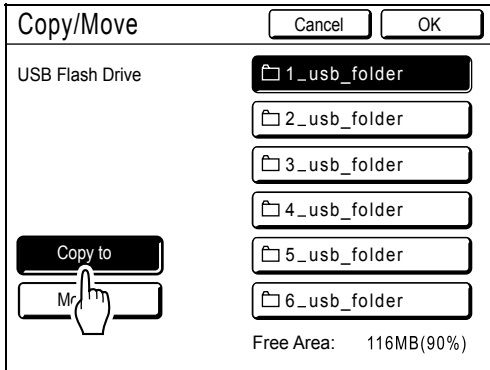

7 Touch the button of the destination folder that you want to copy or move the data to.

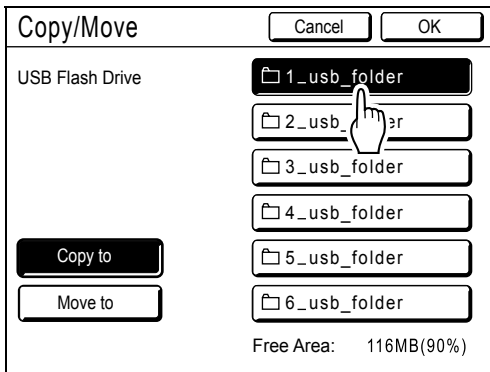

8 Touch [OK].

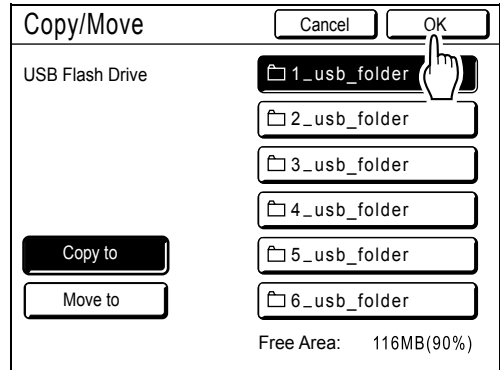

The following screen appears.

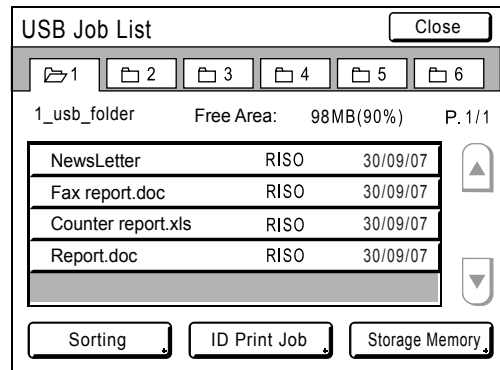

Data is copied/moved and the selected destination folder is displayed.

When the remaining free space of the USB Flash Drive is limited, the following message is displayed. Touch **[USB Job List]** to organize the data of USB Flash Drive, or touch **[Cancel]** to cancel copying/moving.

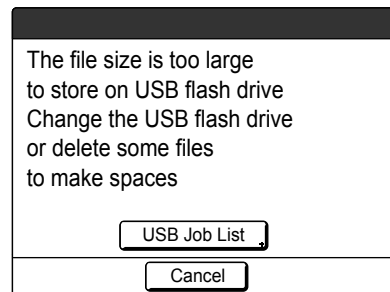

Important!:

- While processing the data, do not remove the USB Flash Drive. This will cause data to disappear and the USB to malfunction.

Replacing Consumables

Check for Remaining Amount of Consumables

The machine checks and reports on remaining amount of ink, master, as well as the space left in the disposal box.

Note:

- The report may not be displayed if detection fails.
- The reported amount is for reference only and may not be perfectly accurate.

1 Touch [i Info] on the Basic Screen.

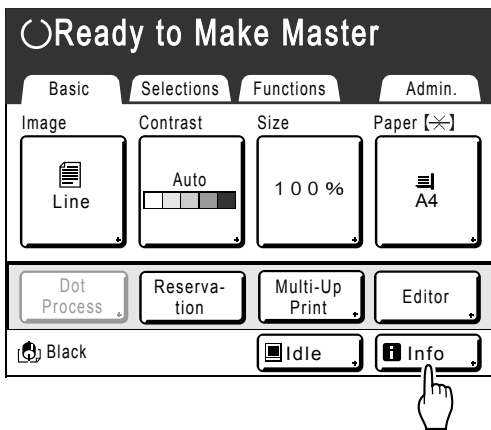

2 Check for remaining amount of consumables.

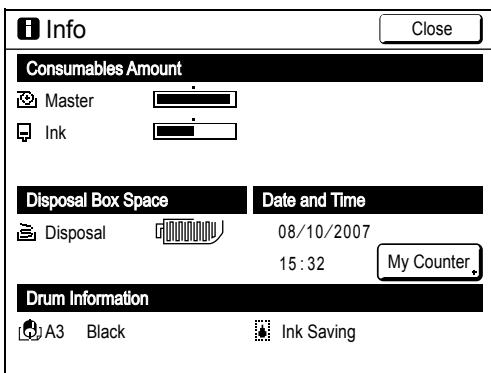

When running low, be sure to restock supply.

- Master (p.202)
- Ink (p.205)
- Master Disposal (used master) (p.207)

Display Details

Indicator/Message	Description
	The black bar indicates the remaining amount. Ex: approximately 10% left
(Unknown), ---, no display	Indicates that consumable data is not available, is not set, etc.

◆ About the “My Counter” screen

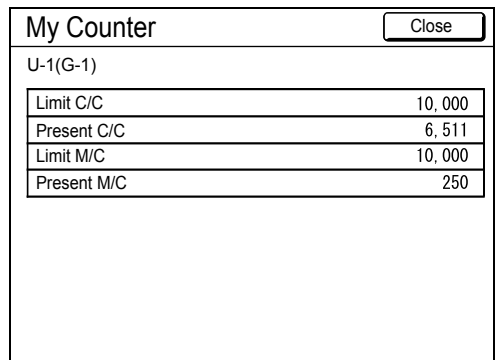

When the “Management Level” in the User Management is set to “High/Full Management”, touch [My Counter] to display “My Counter” screen.

On the “My Counter” screen, you can confirm the current user’s Limit C/C, M/C and Present C/C, M/C. Limit C/C and M/C are set by the administrator. Consult your administrator for details.





Tip:



 Information Button

 icon on the  Information Button displays current status of the consumables as detected by the machine.

The  icon will change depending on the matching information detected from the consumable.

- When matching information was correctly retrieved from the consumable  (normal display)
- When matching information is not available  (gray display)

When the  icon is grayed, the remaining amount of master/ink cannot be displayed.

When the master material or ink runs low,  (master) or  (ink) icon blinks on the right of the button to let you know that the item should soon be replaced.

Note:

- If the machine is unable to retrieve matching data from the consumable, you must enter the correct setting value.

 p.232

Replacing the Master Roll

When the Master Roll is depleted, a message is displayed and the machine stops. Replace with a new Master Roll.

Important!:

- For the Master Roll, it is recommended to use the products specified by RISO.
- Keep the power ON while replacing the master.

1 Open the Front Cover.

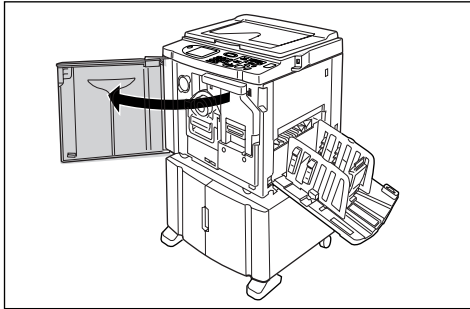

2 Check the indicator of the Master Making Unit Release Button is ON.

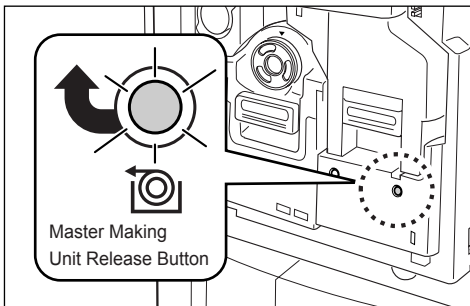

If the indicator is off, press the Master Making Unit Release Button to turn it on.

Important!:

- When the Print Drum (Cylinder) is out, Master Making Unit cannot be pulled out. Return the Print Drum (Cylinder) into position and press the Master Making Unit Release Button.
p.209

3 Pull out the Master Making Unit.

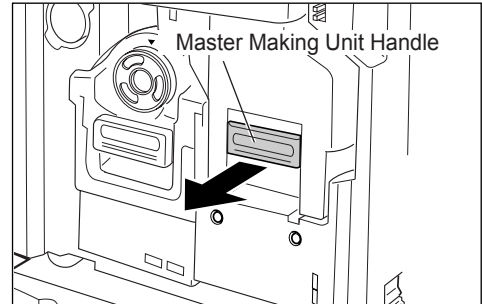

Grasp the Master Making Unit Handle and pull forward.

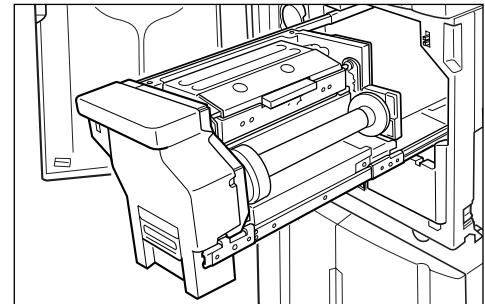

Pull out slowly until it stops.

4 Open the Master Making Unit Cover.

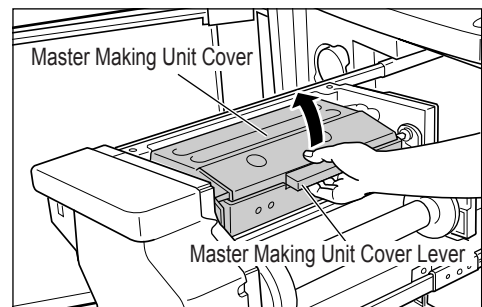

Grasp the Master Making Unit Cover Lever and open the Master Making Unit Cover.

5 Open the Master Roll Holder.

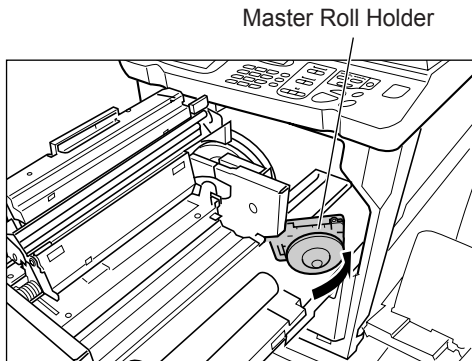

6 Remove the depleted Master core.

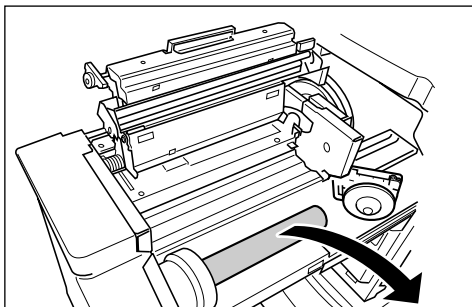

Note:

- Dispose the depleted master core according to the disposal rule of your local community. p.212

7 Install a new Master Roll.

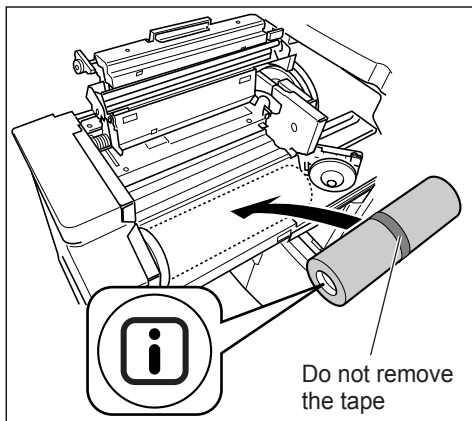

Remove the plastic shrink wrap from the new Master Roll, and place in with the **i** mark to the left.

Important!:

- Take care not to damage the **i** section when removing the shrink wrap. If the **i** section is bent or the perforation cut, the master will become unusable.
- Do not remove the tape yet.

8 Close the Master Roll Holder.

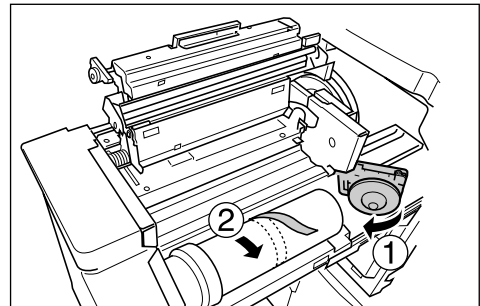

Remove the tape once the Master Roll Holder has been closed.

9 Insert the leading edge of the master under the Master Guide Flap.

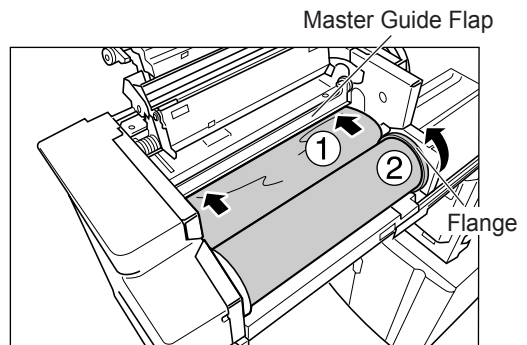

Insert the leading edge of the master into its entrance under the Master Guide Flap and advance it as far in as it will go (①). If the Master is loose, turn the flange at the right towards the rear and rewind (②).

Tip:

If You Cannot Insert the Master

Insert the leading edge of the Master using the following steps.

- 1) Raise the Master Guide Flap
Turn the dial on the edge of the Master Guide Flap towards the rear and raise the Master Guide Flap.
- 2) Pull out the master to the line indicated by the arrow.
- 3) Lower the Master Guide Flap.

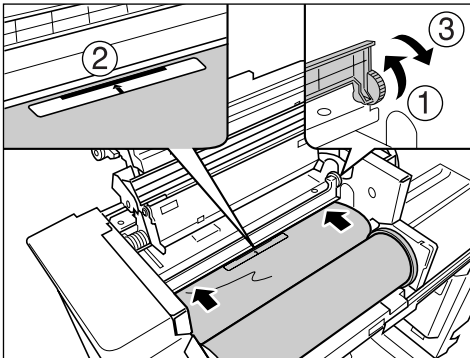

10 Return each part to its original position.

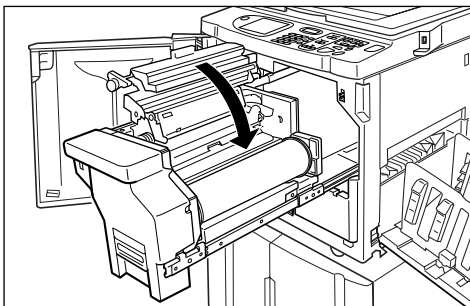

Close the Master Making Unit Cover.

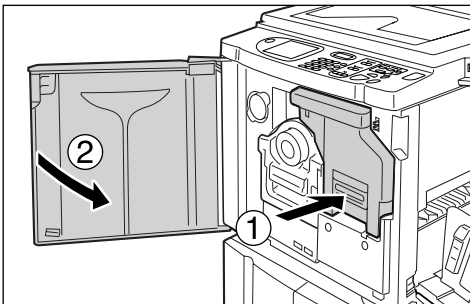

Return the Master Making Unit to its original position and close the Front Cover.

Replacing the Ink Cartridge

When the ink is depleted, a message is displayed and the machine stops.
Replace with a new Ink Cartridge.

⚠ Caution:

- Ink may be left on the area around the Print Drum (Cylinder), so take care not to smudge your hands or clothes.
- Wash immediately with soap if you should get ink on your hands, etc.

Important!:

- For the Ink Cartridge, it is recommended to use the products specified by RISO.
- Keep the power ON while replacing the Ink Cartridge.
- Replace with an Ink Cartridge of the same ink color (colour). If you want to change the ink color (colour), replace the Print Drum (Cylinder) itself.
☞ p.209

1 Open the Front Cover.

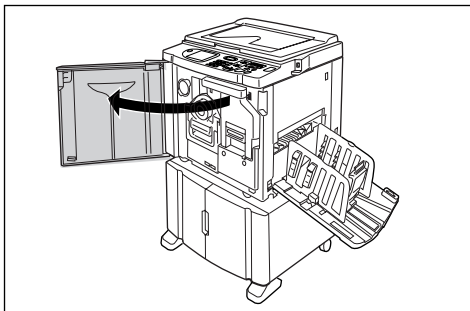

2 Pull the empty Ink Cartridge out of the holder.

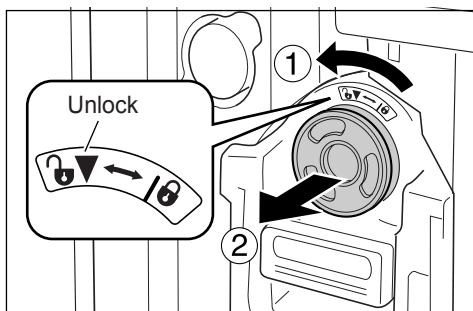

Turn the Ink Cartridge to the counter clockwise (🔓) and then pull it out.

Note:

- Dispose the empty Ink Cartridge according to the disposal rule of your local community.
☞ p.212

3 Remove the cap on the new Ink Cartridge.

Turn the Ink Cartridge cap to remove.

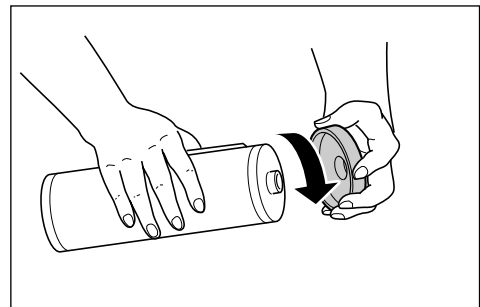

Important!:

- Do not touch or give impact to the outlet surface of the new Ink Cartridge.
Do not peel off the label beside the Ink Cartridge opening.

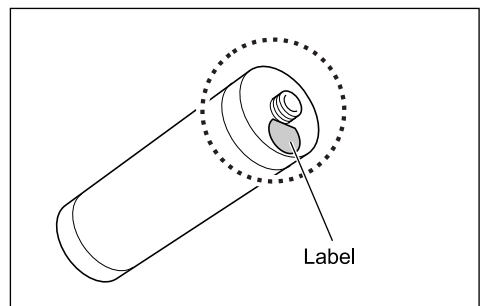

Note:

- You can store the Ink Cartridge cap on the upper left of the Print Drum (Cylinder).

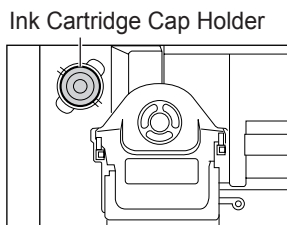

4 Insert the new Ink Cartridge.

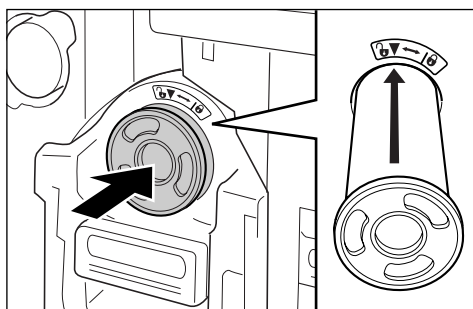

Align the arrow on the Ink Cartridge to the ▼ mark on the drum (cylinder) unit, and insert until it stops.

5 Lock the Ink Cartridge.

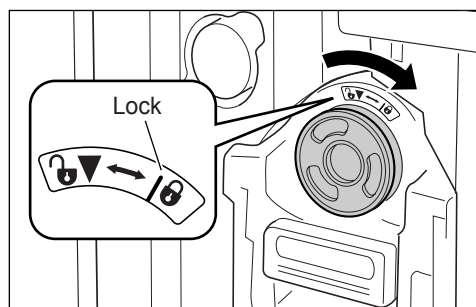

Turn the Ink Cartridge clockwise (🔒) and lock in position.

6 Close the Front Cover.

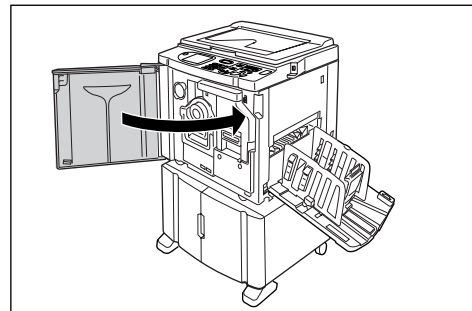

Emptying the Master Disposal Box

Used masters are held in the Master Disposal Box. When the Master Disposal Box becomes full, a message displays and the machine stops. Discard the used masters.

⚠ Caution:

- Wash immediately with soap if you should get ink on your hands, etc.

Important!:

- The Master Disposal Box can be padlocked to prevent the information contained in the discarded master from being leaked. If the Master Disposal Box is safely protected by the padlock, be sure to contact the administrator before discarding the master.
- When “Protect” is ON, you can remove the Master Disposal Box only when the messages such as “Master Disposal Box is Full” or “Master Jammed in Disposal Unit” are displayed. ↪ p.178

1 Remove the Master Disposal Box.

If the Master Disposal Box lever is locked, slide the lever to the right to unlock.

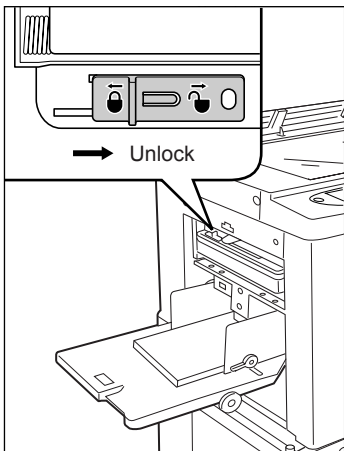

Grasp the Master Disposal Box handle and pull the box forward.

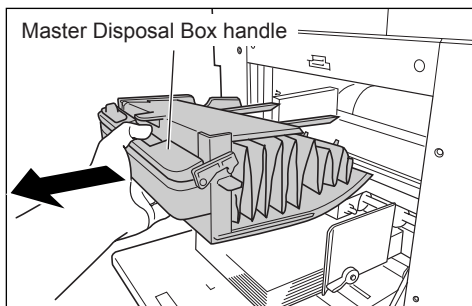

Important!:

- If the Master Disposal Box is padlocked, contact the administrator to undo the padlock.

2 Discard the ejected masters.

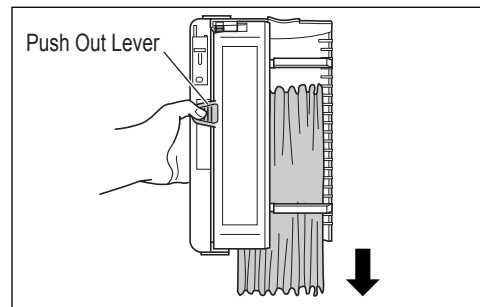

Tilt the Master Disposal Box forward and directly discard the used master into the garbage box (or bag) by grasping the Push Out Lever.

3 Place the Master Disposal Box into position.

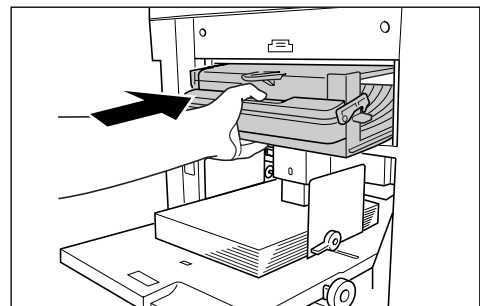

Insert the Master Disposal Box until it stops.

Note:

- If necessary, slide the lever to the left to lock the Master Disposal Box and also have the padlock for further safety.

☞ p.178

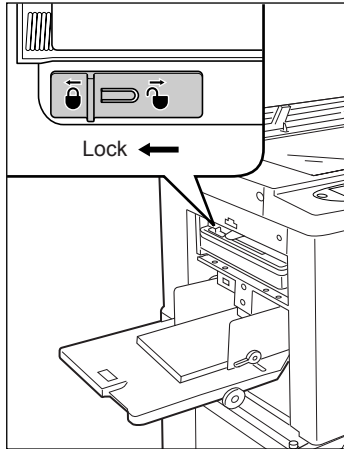

- Dispose the ejected masters according to the disposal rule of your local community.

☞ p.212

Replacing the Print Drum (Cylinder) (Color (colour) Change)

When replacing with a Color Drum (Cylinder) to change colors (colours), or when removing jammed paper, follow the steps to remove Print Drum (Cylinder). Be sure to use a Color Drum (Cylinder) specifically designed and approved for use with this machine.

⚠ Caution:

- Do not stand the Print Drum (Cylinder) upright. Doing so may stain the floor, etc.

Important!:

- Use only Print Drums (Cylinders) specifically designed and approved for use with this machine.
- Keep the power ON while removing or replacing the Print Drum (Cylinder).
- Make sure to place the changed Print Drum (Cylinder) into the drum (cylinder) case and store horizontally.

Removing the Print Drum (Cylinder)

1 Open the Front Cover.

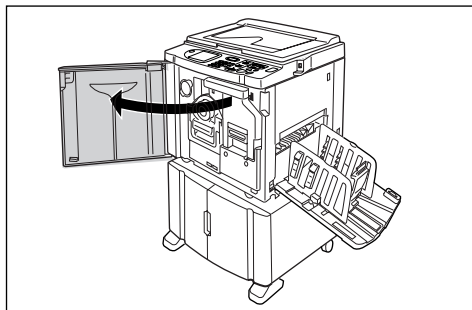

2 Check that the indicator of the Print Drum (Cylinder) Release Button is ON.

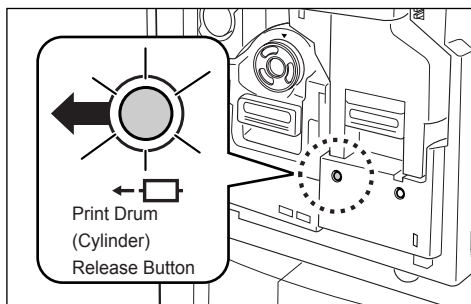

If the indicator is off, press the Print Drum (Cylinder) Release Button to turn it on.

Important!:

- When the Master Making Unit is out, the Print Drum (Cylinder) cannot be pulled out. Return the Master Making Unit into position and press the Print Drum (Cylinder) Release button.
☞ p.202

3 Pull out the Print Drum (Cylinder).

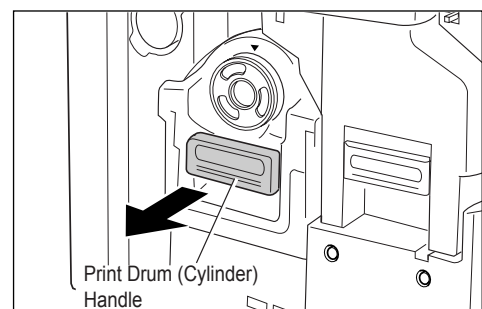

Grasp the Print Drum (Cylinder) Handle and slowly pull until the Print Drum (Cylinder) is completely extended.

4 Remove the Print Drum (Cylinder).

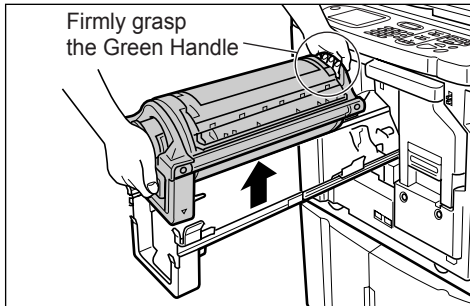

Use both hands to lift the Print Drum (Cylinder) straight up to remove from the rail. Proceed with replacing the drum (cylinder), removing the paper jam, etc..

⚠ Caution:

- Do not touch the connector on the Print Drum (Cylinder). Neglecting this may result in malfunction of the Print Drum (Cylinder) because of static electricity or other factors.

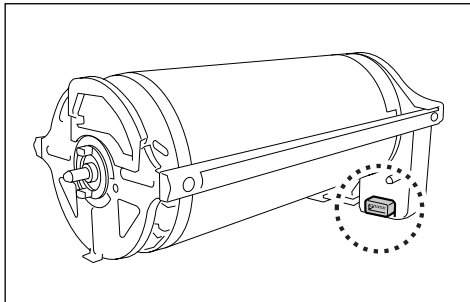

Installing the Print Drum (Cylinder)

1 Place the Print Drum (Cylinder) on the Rail.

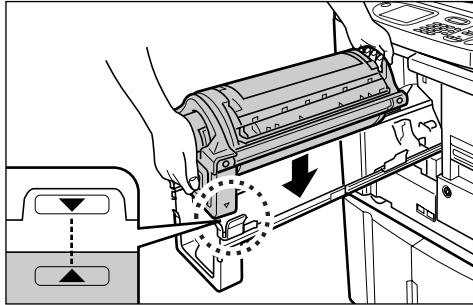

Align the ▼ mark on the Print Drum (Cylinder) with the ▲ mark on the guide, and place the Print Drum (Cylinder) horizontally onto the rail.

Note:

- If the Print Drum (Cylinder) was manually rotated, be sure to turn it back so that ► and ◀ marks align, after it is placed on the rail.

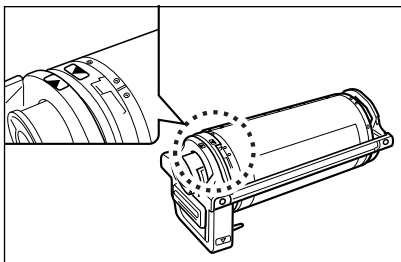

2 Return the Print Drum (Cylinder) to its original position.

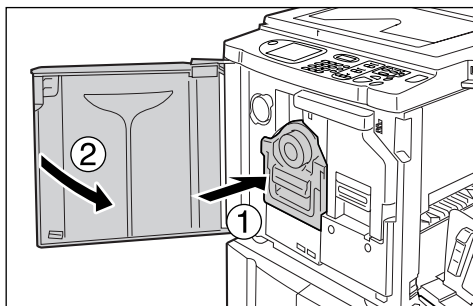

Push the Print Drum (Cylinder) in as far as it will go, and then close the Front Cover.

Important!:

- Do not grasp the Print Drum (Cylinder) Handle when pushing in the Print Drum (Cylinder).

Tip:

Changing the Drum (Cylinder) Type

When you install a different type of Print Drum (Cylinder), the Confirm Drum (Cylinder) Type screen appears.



- 1) Select the type corresponding to the installed Print Drum (Cylinder).
- 2) Touch [OK].
The Print Drum (Cylinder) type is confirmed and printing is enabled.

Important!:

- You will not be able to print until the Print Drum (Cylinder) type is confirmed.
- If you install a non-approved Color Drum (Cylinder), the message “Wrong-Type Print Drum (Cylinder) Installed Replace with Correct Type” is displayed. Install a Color Drum (Cylinder) specifically approved for use with this machine.

Disposal of Depleted Consumables

Dispose of depleted Ink Cartridges, Master cores, ejected masters according to the regulations in your local community.

If required, separate the specific components using the following procedures to dispose them properly.

◆ Ink Cartridge

Remove the label (metal included) at the arrow from the outlet surface of the Ink Cartridge, and then dispose them separately.

Because ink may have adhered to the outlet surface of the Ink Cartridge, be careful not to smudge your clothes.

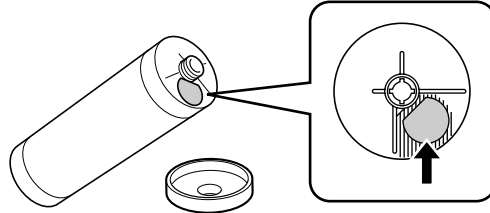

Parts	Materials
Ink Cartridge material	plastic (polypropylene/polyethylene)
Label material	plastic (metal included)
Ink	Soy oil, petroleum hydrocarbons, water, pigments

◆ Master core

A metallic component has been attached to the bottom of the end section having the  mark stamped.

Because the component section has been perforated for cutout convenience, tear along the perforation for proper disposal.

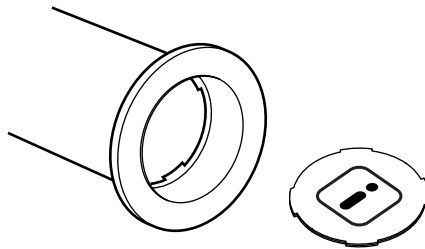

Parts	Materials
Core material	Paper
Master material	plastic, Japanese paper
Material of the cutout component	plastic (metal included) and paper

◆ Ejected Master

Parts	Materials
Master material	plastic, Japanese paper
Ink material	Soy oil, petroleum hydrocarbons, water, pigments

Note:

- It is made of carbon and hydrogen compounds. If fully combusted, it will turn into water and carbon dioxide.



Maintenance

Cleaning

The print quality may suffer if parts such as Thermal Print Head of the Master Making Unit, Scanner Glass of the ADF unit (Option), White Roller, etc. are contaminated with dust, dirt, ink, white-out, etc..

Follow the steps below for periodic cleaning.

⚠ WARNING:

- Before cleaning any part of the machine, turn off the power.
- Do not remove any fixed covers.
- Contact your service representative immediately if you suspect any dangerous situations or have questions or problems with the machine.
- Contact your service representative before moving the machine.
- Do not allow unauthorized persons to make adjustments or repairs.

⚠ Caution:

- The machine has precision moving parts inside. Do not handle the machine in any other way than described in this manual.
- Be careful of the edge of metal parts, otherwise it may cause an injury.
- Do not make any modifications to the machine or remove any parts.
- Neither RISO nor its dealer is responsible for maintenance service performed by non-RISO-authorized personnel.

Thermal Print Head

Clean the Thermal Print Head each time you replace the Master Roll.

Open the Master Making Unit Cover, and gently wipe the Thermal Print Head in the back of the unit several times with a soft cloth or tissue.

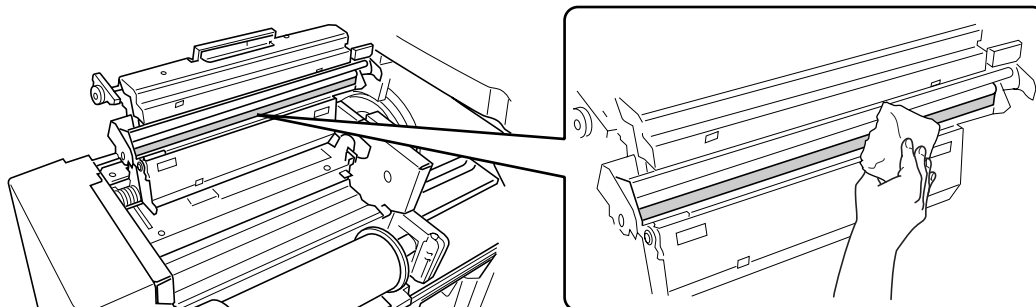

⚠ Caution:

- Since the Thermal Print Head is very delicate, avoid shocks or scratches with a hard object.
- Since Thermal Print Head is susceptible to (damage by) static electricity, please be sure to remove the static electricity charged in the body before cleaning.

Glass Platen and Platen Cover Pad

If the Glass Platen and/or Platen Cover Pad is stained, gently wipe them with a soft cloth or tissue.

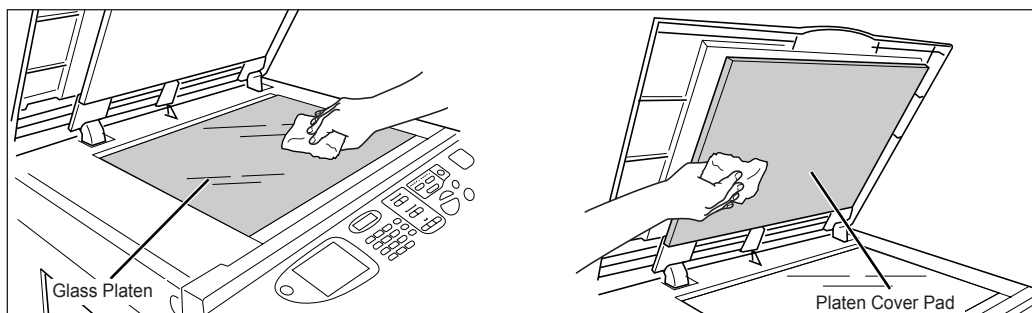

⚠ Caution:

- Since the Glass Platen is very delicate, avoid shocks or scratches with a hard object.

Scanner Glass and White Sheet of ADF unit (Option)

Gently wipe the Scanner Glass, and the White Sheet several times with a soft cloth or tissue.

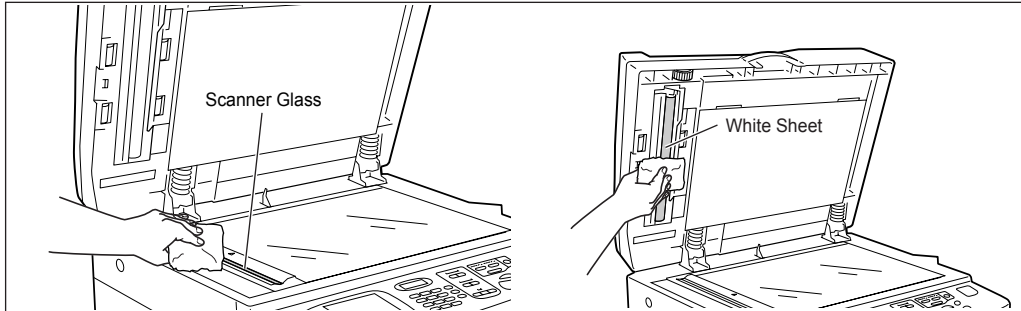

⚠ Caution:

- Since the Glass Platen is very delicate, avoid shocks or scratches with a hard object.

Pressure Roller

If the Pressure Roller, which presses print paper against the Print Drum (Cylinder), is stained, smudged strips may appear on the back of copies.

If this happens, gently wipe the Pressure Roller with a soft cloth dampened with alcohol.

To remove the Print Drum (Cylinder), see [p.209](#).

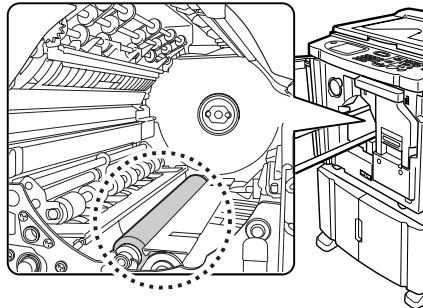

⚠ Caution:

- Be sure to turn OFF power to the machine when cleaning the Pressure Roller.
- When putting your hand into the unit, do not touch the paper separation hook or master removal hook. The sharp tips of the hooks can hurt your hand.
- Ink may be left on the area near the Print Drum (Cylinder), so take care not to smudge your hands or clothes. Wash immediately with soap if you should get ink on your hands, etc.

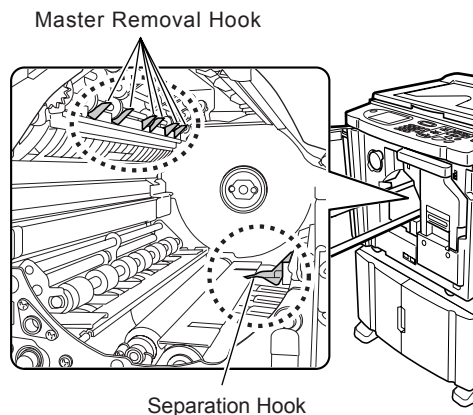

The Exterior

Use a soft cloth to gently wipe down the entire printer on a regular basis in order to prevent the exterior from getting dirty.

If using a cleaning agent, use one recommended by your authorized service representative.

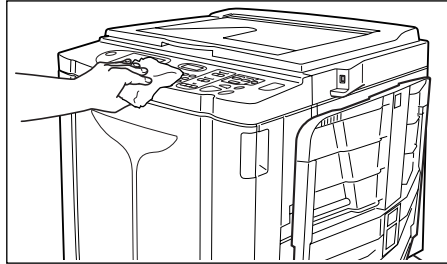

⚠ Caution:

- Because the machine exterior is plastic, never use alcohol or solvent when cleaning.
- The Display may be cleaned by gently wiping with a dry cloth. Dampen a cloth with a small amount of cleaner and gently wipe to remove any ink.
Do not spray or pour cleaner solution directly onto the display. Doing so can cause damage.

Troubleshooting

When a Message Displays

Refer to the following information to determine the cause and take appropriate actions when the machine stops operating and a message is displayed.

Error Message Layout

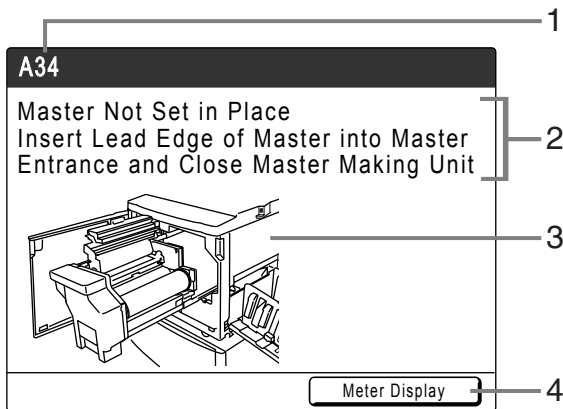

A message and a troubleshooting illustration will be displayed in accordance with the message type to show how to resolve the problem.









- 1) **Error Number**
error type and error ID number
- 2) **Error Messages**
description of the error and actions to resolve the problem
- 3) **Graphic Area**
visually demonstrates how to resolve the problem
- 4) **Meter Display**
touch to display the “Meter Display” window

Error Number	Error Types	Description	Reference page
T00-000	Service Call Errors	Errors that require repair or inspection by an authorized service representative. To resolve a Service Call Error, contact your dealer (or authorized service representative) with the error number.	☞ p.219
A00-000	Master Jam Errors	Displays when the master is jammed, etc..	☞ p.219
B00-000	Optional Device Errors	Displays when an error occurs on the optional device.	☞ p.220
C00-000	Consumable Errors	Displays when a consumable such as ink or master roll is depleted.	☞ p.221
D00-000	Installation Errors	Displays when a part or unit is not properly installed.	☞ p.222
J00-000	Paper Jam Errors	Displays when an original document or printing paper is jammed.	☞ p.224

T00-000:Service Call Errors (in alphabetical order)

Message	Possible Cause	Action
!!Low Battery!! Call Service	The battery is low or depleted.	Contact your dealer (or authorized service representative) and have the battery replaced. Press the  key or the  key to clear the error message display.
!!System Error!! Press Reset Key If Recovery has Failed, Call Service	A system error has occurred.	Press the  key. If the problem persists, contact your dealer (or authorized service representative).
!!System Error!! Turn Main Power SW OFF Then ON If Recovery has Failed, Call Service		Shut off power, then restart. If the problem persists, contact your dealer (or authorized service representative).

A00-000:Master Jam Errors (in alphabetical order)

Message	Possible Cause	Action
Master Disposal Error Pull Out Print Drum (Cylinder) and Discard Master	The master was not properly discarded.	<ol style="list-style-type: none"> 1) Pull out the Print Drum (Cylinder) and remove the master from the drum (cylinder).  p.209 2) Return the Print Drum (Cylinder) in place. 3) Press the  key.
Master Jammed in Disposal Unit Pull Out Master Disposal Box and Remove Jammed Master	The master is jammed in the Master Disposal Unit.	Pull out the Master Disposal Box and remove the jammed master.  p.207 If the error persists, contact your dealer (or authorized service representative).
Master Loading Error Pull Out Print Drum (Cylinder) and Discard Master	The master did not properly attach to the Print Drum (Cylinder).	<ol style="list-style-type: none"> 1) Pull out the Print Drum (Cylinder) and remove the master from the drum (cylinder).  p.209 2) Return the Print Drum (Cylinder) in place. 3) Press the  key.
Master Mis-Feed Pull Out Master Making Unit and Rewind Master Roll, then Reset Master in Place	The master is improperly installed.	Pull out the Master Making Unit, rewind the master and reinstall.  p.202
Master Not Set in Place Insert Lead Edge of Master into Master Entrance and Close Master Making Unit	The master is improperly installed or is missing.	Pull out the Master Making Unit and reinstall the master.  p.202 Important!: <ul style="list-style-type: none"> • If the leading edge of the master is wrinkled or torn, cut the edge straight and reinstall.

Message	Possible Cause	Action
Master Remains on Print Drum (Cylinder) Pull Out Print Drum (Cylinder) and Remove Master	An unnecessary master remains on the Print Drum (Cylinder).	<ol style="list-style-type: none"> 1) Pull out the Print Drum (Cylinder) and remove the master from the drum (cylinder). ☞ p.209 2) Return the Print Drum (Cylinder) in place. 3) Press the  key.
Safety SW on Standard Feed Tray is Activated Reset paper on Standard Feed Tray	The safety switch for the Standard Feed Tray (Paper Feed Tray) has been activated.	Check underneath the Standard Feed Tray (Paper Feed Tray) and on top of the printing paper for any obstructions. Remove if any exist.
System Error in Master Making Unit Take Out Master and then Close Master Making Unit Cover	The cutter mechanism for the master malfunctioned.	Pull out the Master Making Unit and remove the master. ☞ p.202 Closing the Master Making Unit Cover will reset the error. Setup the master again.

B00-000:Optional Device Errors (in alphabetical order)

Message	Possible Cause	Action
Can not identify	<ul style="list-style-type: none"> • Something other than the USB Flash Drive is connected to the USB slot. • A defective USB Flash Drive is connected to the USB slot. • A USB Flash Drive not recognized for this machine is connected to the USB slot. 	Connect a USB Flash Drive for this machine. ☞ p.11
	Insufficient free space of the USB Flash Drive.	Connect the USB Flash Drive to the USB slot after increasing the free space of USB Flash Drive by a computer.
Can not identify (USB hub)	A USB hub is connected to the USB slot.	Connect the correct corresponding USB Flash Drive. ☞ p.11
Check Sorter's Panel Display	Optional sorter error.	Check the sorter's panel. See the instruction manual of the sorter for its operations.
Close Sorter's Cover	Optional sorter cover is open.	Close the sorter cover.
Insert Card in Key/Card Counter	No card in the Key Card Counter (option).	Insert Card in the Key Card Counter.
!! Job Separator is OFF !! Turn On Power Switch of it	The Job Separator (option) is turned OFF.	Turn on the Job Separator.
No IP Address Assigned to This Printer Contact Your Network Administrator	IP address for the machine is not properly set.	Contact your system administrator and set the machine IP address correctly. ☞ p.164
No Paper Tape in Job Separator Replace Tape Roll	No tape in the Job Separator (option).	Load new tape into the Job Separator.

Message	Possible Cause	Action
Paper Tape Jam in Job Separator Remove Paper Tape	Tape jam occurred in the Job Separator (option).	Check the Job Separator and remove jammed tape.

C00-000:Consumable Errors (in alphabetical order)

Message	Possible Cause	Action
Add Paper	No printing paper in the Paper Feed Tray.	Load paper into the Paper Feed Tray. ☞ p.32
Master Disposal Box is Full Empty Master Disposal Box	The Master Disposal Box is full.	Empty the Master Disposal Box. ☞ p.207
No Ink Replace Ink Cartridge	The ink is depleted.	Replace and install a new Ink Cartridge. Use the Ink Cartridge specifically designed and approved for use with this machine ☞ p.205 Important!: • If the error persists after replacing the Ink Cartridge, check for proper installation of the Ink Cartridge.
No Master Replace Master Roll	The Master Roll is depleted.	Install a new Master Roll. Use Master Roll specifically designed and approved for use with this machine ☞ p.202

D00-000:Installation Errors (in alphabetical order)

Message	Possible Cause	Action
Close Front Cover	The Front Cover is open or improperly closed.	Check for the magnet underneath the Front Cover and firmly close.
Close Master Making Unit Cover	The Master Making Unit Cover is open or is improperly installed.	Pull out the Master Making Unit, check and firmly close its cover.
Install Ink Cartridge	The Ink Cartridge is improperly installed or is missing.	Properly install the Ink Cartridge. ☞ p.205
Master Making Unit has been Unlocked	The Master Making Unit is ready to be pulled out.	Pull out the Master Making Unit.
Print Drum (Cylinder) has been Unlocked	The Print Drum (Cylinder) is ready to be pulled out.	Pull out the Print Drum (Cylinder).
Print Drum (Cylinder) Not Set in Place Press Print Drum (Cylinder) Release Button and Pull Out Print Drum (Cylinder) after the Button Lights	The Print Drum (Cylinder) is locked but not pushed in properly.	Push the Print Drum (Cylinder) in as far as it will go and press the Print Drum (Cylinder) Release Button . Remove the Print Drum (Cylinder) after the button is lit and reinstall.
Rear Cover of Main Body is Off Call Service	The machine rear cover is removed.	Contact your dealer (or authorized service representative).
Set Master Disposal Box in Place	The Master Disposal Box is improperly set or is missing.	Properly set the Master Disposal Box. ☞ p.207
Set Master in Place	No master is installed.	Install a Master Roll. ☞ p.202
Set Master Making Unit in Place	The Master Making Unit is missing or is improperly installed.	Properly install the Master Making Unit. ☞ p.202
Set Print Drum (Cylinder) in Place	The Print Drum (Cylinder) is improperly set or is missing.	Properly install the Print Drum (Cylinder). ☞ p.209
Wrong-type Ink Cartridge Installed or Cannot Read Ink Info Replace Ink Cartridge or Contact dealer/Riso office	Inappropriate Ink Cartridge is installed.	Properly install a correct Ink Cartridge. ☞ p.205 Important!: • Use the Ink Cartridge specifically designed and approved for use with this machine. Failure to do so may cause problems or damage to the machine.
	The label on the Ink Cartridge outlet surface has come off or surface is with dirt.	The label on the Ink Cartridge outlet surface contains information needed for printing. If the machine cannot read the information, it does not operate. Set an Ink Cartridge that is specific to the machine and that is with label attachment and free from dirt.

Message	Possible Cause	Action
<p>Wrong-type Master Installed or Cannot Read Master Info Replace Master Roll or Contact dealer/Riso office</p>	<p>Incorrect master is installed.</p>	<p>Set a correct Master Roll. ☞ p.202</p> <p>Important!:</p> <ul style="list-style-type: none"> • Use a Master Roll specifically designed and approved for use with this machine. Failure to do so may cause problems or damage to the machine.
	<p>The ⓘ section on the master core is missing, or it has worn off, or it has been tilted.</p>	<p>The ⓘ section on the master core contains information needed for making masters. If the machine cannot read the information, it does not operate. Set a dedicated Master Roll that has the ⓘ mark and is free from wear and tilt.</p>
<p>Wrong-Type Print Drum (Cylinder) Installed Replace with Correct Type</p>	<p>Incorrect Print Drum (Cylinder) is installed.</p>	<p>Install a correct Print Drum (Cylinder). ☞ p.209</p> <p>Important!:</p> <ul style="list-style-type: none"> • Use a Print Drum (Cylinder) specifically designed and approved for use with this machine. Failure to do so may cause problems or damage to the machine.

J00-000:Paper Jam Errors

Displays when the original document or printing paper is jammed inside the machine, the ADF unit (Option) or Sorter (option). The location of the paper jam is indicated by the flashing icon (① - ⑤) in the illustration. Refer to the table below (① - ⑤) and resolve the issue as indicated.

Note:

- Use appropriate printing paper to prevent paper jams. Also select appropriate original document suitable for the ADF unit (Option).
 - ☞ p.15
 - ☞ p.17

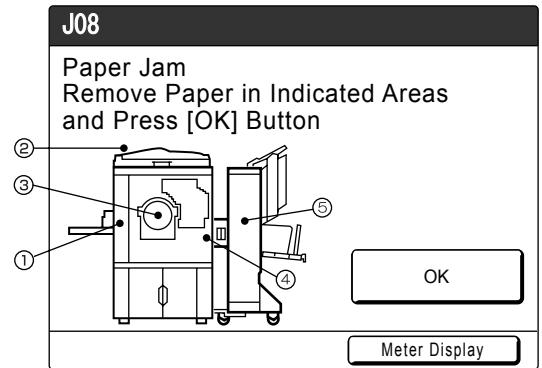

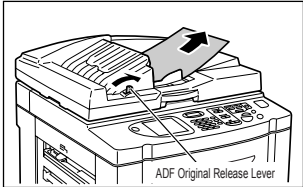
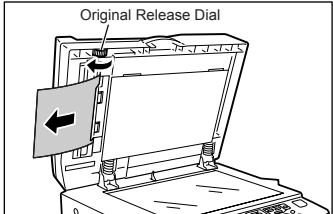
Area Indicated/ Blinking	Possible Cause	Action
①	Paper is jammed in the Paper Feed area.	<ol style="list-style-type: none"> 1) Check the paper feed side and remove the jammed paper. 2) Reload printing paper. 3) Press the  key if error display does not clear. When using special paper, adjust the Paper Feed Pressure Adjustment Lever according to the paper characteristics. ☞ p.33
②	The original is jammed in the ADF unit (Option).	<p>Removing in the document insertion direction Pull the ADF Original Release Lever (Option) to the right, and remove the original.</p>  <p>When removing in the document ejection direction Raise the Platen Cover, turn the ADF Original Release Dial and remove the original.</p> 

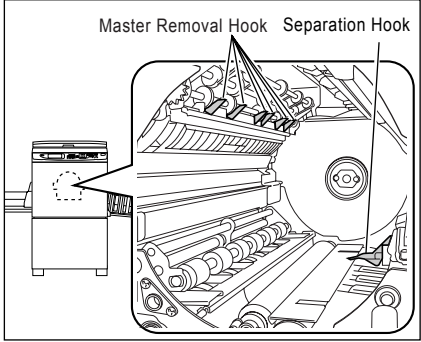
Area Indicated/ Blinking	Possible Cause	Action
③	Paper is jammed in the Print Drum (Cylinder) area.	<p>1) Pull out the Print Drum (Cylinder). ☞ p.209</p> <p>2) Remove the jammed paper.</p> <p>⚠ Caution:</p> <ul style="list-style-type: none"> Do not touch the separation hook or master removal hook when putting your hand into the unit to remove paper. The sharp tips of the hooks can hurt your hand.  <p>The diagram shows a cross-section of the printer's internal mechanism. Two hooks are labeled: 'Master Removal Hook' and 'Separation Hook'. The Master Removal Hook is a larger, curved hook, and the Separation Hook is a smaller, sharper hook. They are positioned near the print drum and paper path.</p>
④	Paper did not eject correctly.	<p>Check for any jammed paper on the paper exit area.</p> <p>When using special paper, adjust the Paper Arranger on the Receiving Tray Paper Guides according to the paper characteristics.</p> <p>☞ p.35</p>
⑤	Paper jam in the Sorter (option).	<p>Remove the jammed paper from the Sorter (option).</p>

Pop-Up Message Layout

Pop-Up Messages communicates various operational statuses.



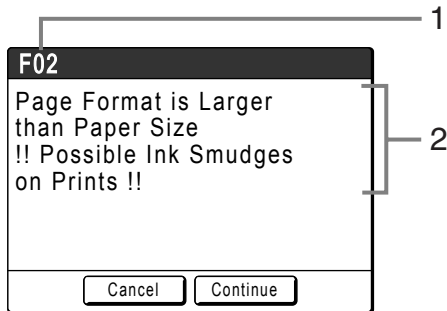

You can continue operation over some of them, but depending upon the context, others will require your action before operations can be resumed.

















- 1) **Error Number**
A reference letter (E/F) and an ID number.
- 2) **Pop-Up Messages**
Content of the message.









Error Number	Error Types	Description	Reference page
E00-000	Maintenance Call	Pops up when battery replacement or a routine inspection by a service personnel is required.	p.226
F00-000	Warning Messages	Pops up when printing job cannot proceed due to a conflict between a Control Panel setting and the status of the machine.	p.227















E00-000: Maintenance Call (in alphabetical order)















Message	Symptom/Action	How to Clear a Pop-Up Message
!!Battery Replacement!! Call Service	(Symptom) Low battery. (Action) Contact your dealer (or authorized service representative) and have the battery replaced.	Touch [Close] . (Alternatively, press the  key or the  key to clear.)
!!Maintenance!! Call Service	(Symptom) Notifies user of need for a periodic maintenance. (Action) Consult your dealer (or authorized service representative).	Touch [Close] . (Alternatively, press the  key or the  key to clear.)





F00-000:Warning Messages (in alphabetical order)

Message	Symptom/Action	How to Clear a Pop-Up Message
Auto Page Size Selection is Not Available for Irregular-Size Original Select Format Size to Store and then Restart	<p>(Cause 1) Attempting to scan an irregular-size original using "Auto" in scanning mode.</p> <p>(Action) Select the original size manually.</p> <p>(Cause 2) A normal-size original has been set in the wrong position.</p> <p>(Action) Lift the Platen Cover Pad up and set the original correctly.</p>	<ul style="list-style-type: none"> • To specify the format for saving Touch [Saving Format]. • To cancel scanning Touch [Cancel]. (Alternatively, press the  key or the  key to clear.)
!! Book Shadow Editor is Not Available with ADF !! Place Original on Glass Platen	<p>(Symptom) ADF is disabled while Book Shadow function is active.</p> <p>(Action) Place the original on the Glass Platen. ☞ p.77</p>	<p>Touch [Close]. (Alternatively, press the  key or the  key to clear.)</p>
Check Stock of Required Ink and Please Order If Needed	<p>(Symptom) The remaining quantity of Ink Cartridge or Master Roll has become less than specified on "Stock Management". ☞ p.166</p>	<p>Touch [Close]. (Alternatively, press the  key or the  key to clear.)</p>
Check Stock of Required Master and Please Order If Needed	<p>(Action) Order Ink Cartridges or Master Rolls if necessary.</p>	<p>Touch [Close]. (Alternatively, press the  key or the  key to clear.)</p>
Check the Original Size The Original Size is larger than Max. Printing Area	<p>(Symptom) As the original size is larger than the maximum printing area, extra areas may not be printed.</p> <p>(Action) Modify the reproduction size.</p>	<ul style="list-style-type: none"> • To change the "Size" setting; Touch [Size Setting]. • When resuming the print job; Touch [Continue]. (Alternatively, press the  key to print.) • When stopping the print job; Touch [Cancel]. (Alternatively, press the  key or the  key to clear.)
Check the Settings The Selected Reproduction Ratio will not fit the Max. Printing Area	<p>(Symptom) Reproduction size is too large for the detected original size and exceeds the maximum printing area.</p> <p>(Action) Modify the reproduction size.</p>	<ul style="list-style-type: none"> • When changing the "Size" setting; Touch [Size Setting]. • When resuming the print job; Touch [Continue]. (Alternatively, press the  key to print.) • When stopping the print job; Touch [Cancel]. (Alternatively, press the  key or the  key to clear.)

Message	Symptom/Action	How to Clear a Pop-Up Message
Close Platen Cover If original moves you may not get desired result	(Symptom) The Platen Cover was opened during the editing process of the RISO Editor function. (Action) Close the Platen Cover gently.	Touch [Close] .
Enter Print Quantity Over [N], Programed Minimum Value	(Symptom) You are trying to print fewer copies than previously specified on "Minimum Print Quantity". (Action) Enter a larger number to print, or change "Minimum Print Q'ty" on the Admin. screen. ☞ p.166	Specify more than the displayed number of copies and press the  key.
!! Images may not fit in Frame of Paper with This Reproduction Size !! Check Current Selection	(Symptom) Reproduction size for the detected original size is larger than paper size. (Action) Modify the reproduction size. ☞ p.55	<ul style="list-style-type: none"> • When resuming the print job; Touch [Continue]. (Alternatively, press the  key to print.) • When stopping the print job; Touch [Cancel]. (Alternatively, press the  key or the  key to clear.)
Invalid Print Drum (Cylinder) has been Selected Change Drum (Cylinder), or Reselect Drum (Cylinder) Size	(Symptom) You have selected a different Print Drum (Cylinder) than the one currently in place, as confirmed in the Confirm Drum (Cylinder) Type screen when it was installed. (Action) Select the type of Print Drum (Cylinder) currently installed. Alternatively, you can change the Print Drum (Cylinder). ☞ p.209	<ul style="list-style-type: none"> • When changing a setting; In the Confirm Drum (Cylinder) Type screen, select the type of Print Drum (Cylinder) currently installed and touch [OK]. • When installing a different Print Drum (Cylinder); Pull out the Print Drum (Cylinder) and replace with the correct one. <p>When the Print Drum (Cylinder) is re-installed, the Warning Message will clear.</p>
!! Multi-Up is Not Available with This Paper Size !! Replace with Proper Paper of Standard Size	(Symptom) Multi-up functions cannot be used when custom-sized paper is in the Paper Feed Tray. (Action) Load standard-sized paper in the Paper Feed Tray.	Touch [Close] . (Alternatively, press the  key or the  key to clear.)
!! No Auto Reproduction Size Selection with This Combination of Original and Printing Paper !! Select Size Manually	(Symptom) Auto Reproduction Size is less than 50% or more than 200%. (Action) Modify the reproduction size.	<ul style="list-style-type: none"> • When changing the "Size" setting; Touch [Size Setting]. • When stopping the print job; Touch [Cancel]. (Alternatively, press the  key or the  key to clear.)

Message	Symptom/Action	How to Clear a Pop-Up Message
<p>!! No Auto Reproduction with This Original and Printing Paper !! Select Size Manually</p>	<p>(Symptom) Auto reproduction is not available because the size of the original could not be detected.</p> <p>(Action) Set the reproduction-size manually.</p>	<ul style="list-style-type: none"> • When changing the “Size” setting; Touch [Size Setting]. • When stopping the print job; Touch [Cancel]. (Alternatively, press the  key or the  key to clear.)
<p>No Master on Print Drum (Cylinder) Make a New Master</p>	<p>(Symptom) You are attempting to print, but there is no master on the Print Drum (Cylinder).</p> <p>(Action) Set the original and create a master.</p>	<p>Touch [Close].</p> <p>Important!:</p> <ul style="list-style-type: none"> • Do not leave the Print Drum (Cylinder) without a master. This dries out the drum (cylinder) and causes damage. You must either create a master or perform a “Confidential” operation to wrap a master around the Print Drum (Cylinder).
<p>Original Size Exceeds Limitation of Multi-Up Specify Original Size</p>	<p>(Symptom) “Multi-Up” is not available for the original size.</p> <p>(Action) Specify the original size.  p.65</p>	<ul style="list-style-type: none"> • When changing the “Original Size” setting; Touch [Original Size]. • When resuming the print job; Touch [Continue]. (Alternatively, press the  key to print.) • When stopping the print job; Touch [Cancel]. (Alternatively, press the  key or the  key to clear.)
<p>Original Undetected Reset Original</p>	<p>(Symptom) The machine failed to detect the original document. The original document may not be placed.</p> <p>(Action) Re-position the original.</p>	<p>Re-position the original to clear the Pop-Up Message.</p> <ul style="list-style-type: none"> • When resuming the print job; Touch [Continue]. (Alternatively, press the  key to print.) • When stopping the print job; Touch [Cancel]. (Alternatively, press the  key or the  key to clear.)
<p>Page Format is Larger than Paper Size !! Possible Ink Smudges on Prints !!</p>	<p>(Symptom) The printing paper is smaller than the Master.</p> <p>(Action) Use a correct size printer paper.</p>	<ul style="list-style-type: none"> • When printing from the machine; Touch [Continue]. (You can also print by pressing the  key.) • When stopping the print job; Touch [Cancel]. (You can also stop by pressing the  key or the  key.)
<p>Page Format is Larger than Paper Size !! Possible Ink Smudges on Prints !! (Continue->PROOF Key)</p>	<p>(Symptom) The printing paper is smaller than the Master.</p> <p>(Action) Use a correct size printer paper.</p>	<ul style="list-style-type: none"> • When printing from the machine; Press the  key. • When stopping the print job; Touch [Cancel]. (You can also stop by pressing the  key or the  key.)

Message	Symptom/Action	How to Clear a Pop-Up Message
Please inform this message to your administrator Due date for ID counter report	(Symptom) Due date for ID Counter Report. (Action) Report to your administrator. ☞ p.154	Touch [Close] . (Alternatively, press the  key or the  key to clear.)
Processing Print Data from PC This Function is Not Available while Processing Current Data	(Symptom) The machine is receiving the document data from the computer. While the data is being transmitted, Scan mode is disabled. (Action) Initiate the Print job after the transmission is complete, or print from the machine.	Touch [Close] . (Alternatively, press the  key or the  key to clear.)
Reached to the limit count Contact the administrator	(Symptom) The upper limit for master-making/printing set by the administrator was reached. (Action) Contact your Administrator.	Touch [Close] . (Alternatively, press the  key or the  key to clear.)
! Scanning is Not Possible ! External CI is not Connected or Processing Connection Check Cable Connection	(Symptom) The scanning function is unavailable due to a lost connection with an external controller or because connection processing has not finished. (Action) Check the connection with the external controller.	Touch [Close] . (Alternatively, press the  key or the  key to clear.)
Set Original and Press Start Key Re-scanning will be Started to Add Image Processing	(Symptom) No original is set on the machine to rescan for image processing by the RISO Editor. (Action) Set the original and scan again.	Touch [Close] . (Alternatively, press the  key or the  key to clear.)
Starting Up Network Card Please Wait a Moment	(Symptom) RISO Network Card (Option) is starting up. (Action) Please wait a moment. Alternatively, print from the machine.	Touch [Close] . (Alternatively, press the  key or the  key to clear.)
!! The Data Storage Area has Become Full !! Clear Old Storage Data	(Symptom) Insufficient free space on the Document Storage Card DM-128CF. (Action) Check the storage data and delete unnecessary jobs.	Touch [Close] . (Alternatively, press the  key or the  key to clear.) • For checking the storage memory Touch [Storage Memory] .

Message	Symptom/Action	How to Clear a Pop-Up Message
<p>The file size is too large to store on USB Flash Drive Change the USB Flash Drive or delete some files to make spaces</p>	<p>(Symptom) Insufficient free space on the USB Flash Drive.</p> <p>(Action) Check the USB Flash Drive data and delete unnecessary jobs.</p>	<p>Touch [Close]. (Alternatively, press the  key or the  key to clear.)</p> <ul style="list-style-type: none"> • For checking the USB Flash Drive data Touch [USB Job List].
<p>!!The Print Drum (Cylinder) Type has been Changed!! Select the Current Print Drum (Cylinder) Type</p>	<p>(Symptom) A different type of Print Drum (Cylinder) has been installed.</p> <p>(Action) Select the type of Print Drum (Cylinder) currently installed. Alternatively, change back to the same type of Print Drum (Cylinder) as before. p.209</p>	<ul style="list-style-type: none"> • When changing a setting; In the Confirm Drum (Cylinder) Type screen, select the type of Print Drum (Cylinder) currently installed and touch [OK]. • When installing a different Print Drum (Cylinder); Pull out the Print Drum (Cylinder) and replace with the same one as before. <p>When the Print Drum (Cylinder) is re-installed, the Warning Message will clear.</p>
<p>!! Unmatched Size-- Current Page and Printing Paper !! Check Paper Size</p>	<p>(Symptom) The original data sent from the computer does not match the print paper size.</p> <p>(Action) Check the print paper size and change paper or size as needed.</p>	<ul style="list-style-type: none"> • When resuming the print job; Touch [Continue]. (Alternatively, press the  key to print.) • When stopping the print job; Touch [Cancel]. (Alternatively, press the  key or the  key to clear.)



Consumable Information Screen

In order to assure optimum printing, the machine acquires information from the consumables. If acquired matching information is not proper, the Consumable Information Screen is shown. Enter appropriate values.

The  icon on the Info Button will be grayed-out when this occurs.

☞ p.201

Note:

- Entering an inappropriate value does not affect usual operations but may result in bad print quality.
- When you perform the following operations, the values set on the “Consumables Information Input Wizard” screen disappears and thus you need to enter the values again.
 - After the power switch is set to  (OFF), the switch is set to  (ON) again
 - After the machine is placed into the Sleep status, the  key is pressed
- If you are not sure the best setting for the consumables used in the machine, we may suggest that you use “1” (default setting) except for “H1” setting and adjust from there if necessary based on the result of the printed copies. Riso takes no responsibility, and cannot advise as to the best setting, for particular consumables not manufactured and sold by Riso.

Ink Information Input Screen

This screen pops up when data could not be obtained from the Ink Cartridge.

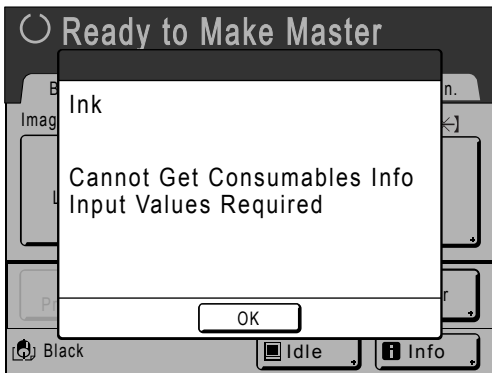

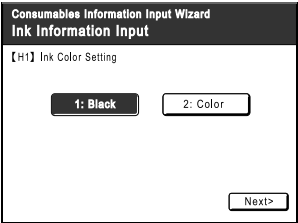

Touch **[OK]** and enter values as shown below.

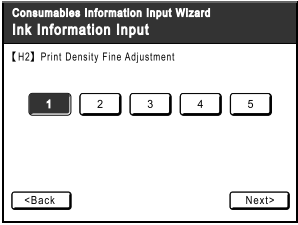
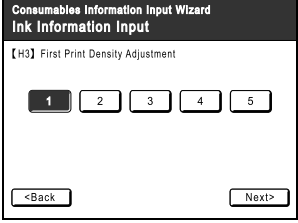
Screen Display	Description	Values
	<p>[H1] Ink Color (Colour) Setting Select the same color (colour) as the Print Drum (Cylinder) currently in use.</p>	<p>1: Black 2: Color (Colour)</p>

Screen Display	Description	Values
	<p>[H2] Print Density Fine Adjustment Select a Print Density level to match the ink to fine-tune print result.</p>	<p>1 (Light) - 5 (Dark)</p>
	<p>[H3] First Print Density Adjustment Select a Print Density level of the first print to match the ink. This can be selected independent of [H2] Print Density Fine Adjustment setting.</p>	<p>1 (Light) - 5 (Dark)</p>

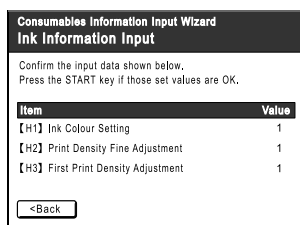
A confirmation screen displays when done.



Press the  key to approve selection.
Returns to the Basic Screen.

Note:

- Master Information Input screen may also display. If so, enter Master Information as well.
[p.233](#)

Master Information Input Screen

This screen pops up when data could not be obtained from the Master Roll.
Touch **[OK]** and enter values as shown below.

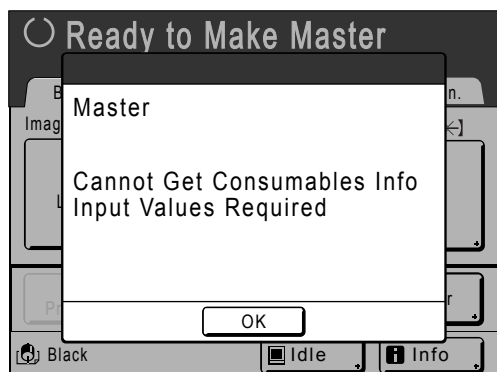

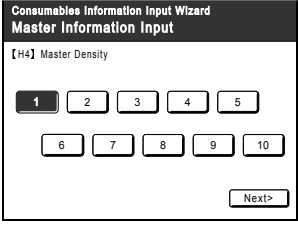
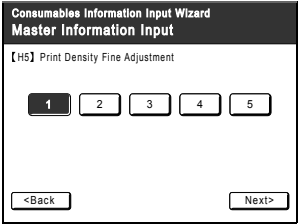
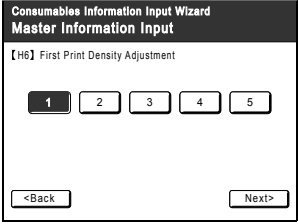
Screen Display	Description	Values
	<p>[H4] Master Density Select the standard density to be applied during creation of the master.</p>	<p>1 (Light) - 10 (Dark)</p>
	<p>[H5] Print Density Fine Adjustment Select a Print Density level to match the master to fine-tune print result.</p>	<p>1 (Light) - 5 (Dark)</p>
	<p>[H6] First Print Density Adjustment Select a Print Density level of the first print to match the master. This can be selected independent of [H5] Print Density Fine Adjustment.</p>	<p>1 (Light) - 5 (Dark)</p>



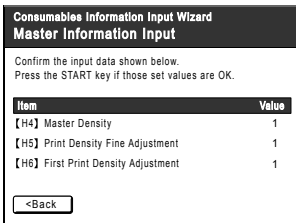



A confirmation screen displays when done.





Press the  key to approve selection.
Returns to the Basic Screen.

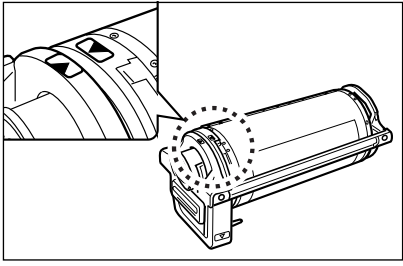

Troubleshooting



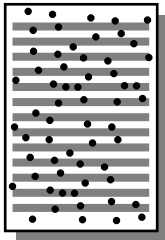

If you run into a problem, consult the following chart first to find answers before calling for a repair.

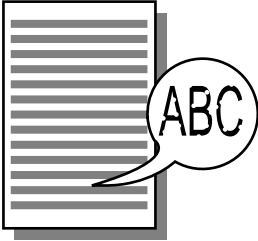

Problem	Possible Cause	Action
The machine does not start up when the power switch is pressed.	You may have pressed the power switch while the machine was in the Sleep Mode.	Try pressing the power switch again. Before pressing the power switch, you may want to find out whether the machine is indeed in the Sleep Mode, by checking the  indicator on the Control Panel. If the  key is lit, the machine is in sleep mode. Press the  key to end sleep mode and to activate the machine.
	Power has been disconnected.	<ul style="list-style-type: none"> • Check the power cord for proper connection to both the machine and the power outlet. • Check the power breaker.
The front cover is closed, but the error message still does not clear.	The Front Cover has not been firmly closed.	Completely close the Front Cover. The magnetic latch should properly engage.
The Paper Feed Tray cannot be closed.	The Feed Paper Tray Guides have not been widened up to the limit.	Turn the power on and lower the Paper Feed Tray to the bottom. Set the Feed Tray Paper Guide Lock Lever to  , widen the Feed Tray Paper Guides up to the limit, and close the Paper Feed Tray. ☞ p.32
	The power was turned off before the Paper Feed Tray was lowered to the bottom.	
The Print Drum (Cylinder) cannot be placed into position.	The Print Drum (Cylinder) was stopped at an inappropriate position after rotation.	After manually rotating the drum (cylinder), make sure that the  mark and the  mark meet as shown. 
	The Print Drum (Cylinder) has not been correctly set to the guide.	Set the drum (cylinder) to the guide correctly. ☞ p.211

Problem	Possible Cause	Action
<p>An error indication does not disappear even though consumables (ink, master roll) are set.</p>	<p>The consumables (ink, master roll) have not been correctly set.</p>	<p>After inserting the Ink Cartridge, turn it clockwise (🔒) to lock. Or set the Ink Cartridge again. 🔗 p.205</p> <p>Set a master roll so that the 📄 mark comes to the left, and set the Master Making Unit. 🔗 p.202</p>
	<p>The Ink Cartridge does not contain ink information.</p>	<p>Do not remove the label attached on the Ink Cartridge outlet section. If you did so, set a new Ink Cartridge. 🔗 p.205</p>
	<p>The master roll does not contain master information.</p>	<p>Do not remove the 📄 section from the master core. If you did so, set a new master roll. 🔗 p.202</p>
<p>The Master Disposal Box cannot be removed.</p>	<p>The “Protect” setting is ON.</p>	<p>If the “Protect” setting is ON, the Master Disposal Box cannot usually be removed. 🔗 p.179</p>
	<p>The Master Disposal Box lever is locked.</p>	<p>Slide the Master Disposal Box lever to the right to unlock. If the Master Disposal Box is padlocked, contact the administrator to release the padlock. 🔗 p.207</p>
<p>There is no image on copies.</p>	<p>The original is placed face up.</p>	<p>Place the original face down. (This is also true for the ADF unit (Option))</p>
	<p>The master is installed with the incorrect side out.</p>	<p>Reinstall the Master Roll with correctly. 🔗 p.202</p>
<p>Some areas are missing in the printed copy.</p> 	<p>The Glass Platen (and/or the ADF Scanner Glass) is not clean.</p>	<p>Clean the Glass Platen (and/or the ADF Scanner Glass). 🔗 p.215</p>
	<p>A foreign object may exist on the master.</p>	<p>Pull out the Print Drum (Cylinder) and check if any object exists on the master. If a foreign object exists between the master and the drum (cylinder), remove the master. Then set the drum (cylinder) and perform the master-making operation again.</p>
	<ul style="list-style-type: none"> • The paper size placed on the Paper Feed Tray was not the same as the size of the original at the time of the master-making process. • The Feed Tray Paper Guides were not fit to the width of paper at the time of the master-making process. 	<p>A master is made according to the size of paper placed on the Paper Feed Tray; namely the width of the Feed Tray Paper Guides and the length of paper. If the size of paper placed on the tray is smaller than the size of the original, a master is not made for the entire original. Set the same size of paper on the tray as the original and perform the master-making operation.</p>

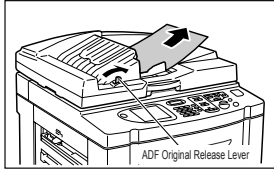
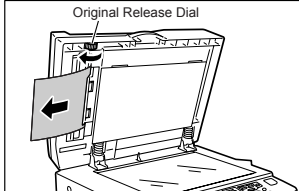

Problem	Possible Cause	Action
<p>Vertical blank lines are found on printed copies.</p> 	<p>The Thermal Print Head of the Master Making Unit or the Scanner Glass of ADF unit (Option) has been stained with dirt, white-out, etc.</p>	<p>Gently wipe the Thermal Print Head or Scanner Glass with a soft cloth. ☞ p.215</p>
<p>The unwanted background of an original is picked up on copies.</p> 	<p>If newspaper or colored (coloured) paper is used as an original, the background is picked up on copies.</p>	<p>Lighten the “Contrast” and create a new master. ☞ p.54</p>
<p>Dirt is found on printed copies.</p>	<p>The Glass Platen (and/or the ADF Scanner Glass) is not clean.</p>	<p>Clean the Glass Platen (and/or the ADF Scanner Glass). ☞ p.215</p>
<p>The edges of printed copies are smudged with ink.</p>	<p>Larger size of paper than the original was placed on the Paper Feed Tray at the time of the master-making process.</p>	<p>Because a master was made according to a larger size than the original, the edges of the original were processed as shadows. Set the same size of paper as the original and perform the master-making operation again. Or attach tape as described below to solve the problem.</p>
	<p>Did you use [Max. Scan] setting when making the master?</p>	
	<p>When printing thick paper such as cards, corners of the paper contacted and damaged the master.</p>	<p>Make another master and print with the new master. Or pull out the Print Drum (Cylinder) and attach cellophane tape to the damaged section on the master. However, if attached with cellophane tape, a master may not be properly sent to the Master Disposal Box.</p>

Problem	Possible Cause	Action
<p>The back of the printed paper is smudged with ink</p> 	<p>The Pressure Roller has been stained with ink.</p>	<p>Remove the Print Drum (Cylinder) and clean the Pressure Roller. ☞ p.216 If the print position is outside the print paper, this may cause the Pressure Roller to be stained with ink. Be careful when changing the size of print paper or shifting the print position.</p>
	<p>The Feed Tray Paper Guides were not fit to the width of paper at the time of the master-making process.</p>	<p>Adjust the Feed Tray Paper Guides to the width of the paper. If the Feed Tray Paper Guides are set wider than the width of the paper, a master will become wider than necessary. ☞ p.32</p>
	<p>Are you using a paper that does not efficiently absorb ink?</p>	<p>The ink did not dry fast enough, marking onto the reverse side of the next paper. Either change the paper or try “Ink Saving” or “Interval” features. ☞ p.64 ☞ p.93</p>
<p>Printed images are faint. Printed texts are blurred.</p> 	<p>If the machine is not used for an extended period of time, ink on the surface of the Print Drum (Cylinder) may dry. This results in faint or blurred printing just after printing is started.</p>	<p>The ink on the Print Drum (Cylinder) will dry when the machine is not in use for an extended period. Printing with dried ink will produce light or faded copies. Press the  key and make several copies before making copies to be actually used. Or use the “Idling Action”. ☞ p.146</p>
	<p>Faint originals result in faint images.</p>	<p>Increase the scanning level and perform the master-making operation again. ☞ p.54 For originals written with a pencil, select the Pencil mode. ☞ p.52</p>
	<p>If the temperature is low (below 15° C (59° F)) in a place where the machine is installed or Ink Cartridges are stored, ink does not flow smoothly.</p>	<p>Use the machine after keeping it at room temperature for a while. ☞ p.11</p>
	<p>The Ink Saving mode has been set.</p>	<p>With the “Ink Saving” mode selected, the ink on printed copies is fainter than usual. ☞ p.64</p>

Problem	Possible Cause	Action
<p>Multi-up did not function. There is nothing printed on one side.</p> 	<p>Did you place the second original in time after the beep, while the message "Place Another Original and Press Start Key" was showing?</p>	<p>When you print using "Multi-Up", the machine will beep during the Multi-Up Interval. Place the second original during that interval. If the machine starts scanning for the second time without a beep, even when you are scanning from the Glass Platen, you will need to adjust "Multi-Up Interval" settings on the Admin. screen. ☞ p.165</p>
	<p>Did you accidentally press the  key while the original was being scanned?</p>	<p>The print operation will stop if the  key is pressed while scanning is in progress. Do not press the  key until all originals have been scanned.</p>
<p>The left and right print positions have been shifted.</p>	<p>The left and right print positions have not been adjusted for the center.</p>	<p>The Paper Feed Tray is equipped with the Horizontal Print Position Adjustment Dial. Lower the tray, adjust the position, and then perform proof copy to check the position. ☞ p.90</p>
<p>Paper sticks to the surface of the Print Drum (Cylinder).</p>	<p>The margin at the top of the original or print is too small.</p>	<p>The margin of the original (top of the print in the paper output direction) must be 5 mm ($\frac{3}{16}$") at least. Lower the vertical print position. If this adjustment is impossible, reproduce an original with enough margin and perform the master-making operation again. ☞ p.55</p>
	<p>The print paper is inappropriate.</p>	<p>Use the recommended paper. ☞ p.15</p>
	<p>The original has a solid black portion at its top.</p>	<p>If an original has a solid black portion at the top, printed copies may not properly output. Replace the original in the reverse direction and restart the master-making process.</p>
<p>Printed and curled copies are output.</p>	<p>The print paper is loaded at a horizontal grain direction.</p>	<p>Load print paper with a vertical grain direction.</p>
<p>Paper gets jammed in the ADF unit (Option).</p>	<p>There is any paper caught in the ADF unit (Option).</p>	<p>Pull the ADF Original Release Lever to the right or turn the Release Original Dial and remove the jammed paper.</p>  

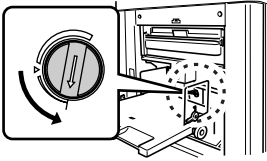
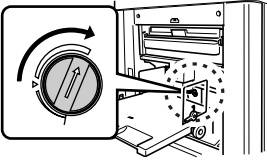
Problem	Possible Cause	Action
<p>Printed copies are not neatly aligned in the Paper Receiving Tray.</p>	<p>The positions of the Receiving Tray Paper Guides and the Paper Stopper are inappropriate.</p>	<p>Adjust the Receiving Tray Paper Guides and the Paper Stopper to the size of paper. For thick paper, slightly widen them as necessary. If you have adjusted the horizontal position on the Paper Feed Tray, shift the Receiving Tray Paper Guides in the same direction. ☞ p.35</p>
	<p>The Paper Arrangers are not properly set.</p>	<p>Set the Paper Arrangers properly. ☞ p.35</p>
	<p>The Paper Feed Pressure Adjustment Lever is positioned incorrectly.</p>	<p>If the Paper Feed Pressure Adjustment Lever is set to “CARD ()”, printed copies may not be correctly aligned when using standard paper. Set the Paper Feed Pressure Adjustment Lever to “NORMAL ()”. ☞ p.33</p>
<p>Paper goes over the receiving tray stopper.</p>	<p>---</p>	<p>Follow the steps to level the receiving tray as follows:</p> <ol style="list-style-type: none"> 1) Fold the Receiving Tray Paper Guides/Stopper. 2) Lift up the sides of the receiving tray with both hands, and move the receiving tray shaft to the position B. Position A is recommended in most cases. <div data-bbox="987 1038 1260 1364" data-label="Image"> </div> <p>A: Ordinary position B: Move to this position when paper goes over the tray.</p>

Problem	Possible Cause	Action
<p>Paper is not smoothly fed from the Paper Feed Tray. (skipped paper, or multiple-sheet feeding)</p>	<p>The print paper is inappropriate.</p>	<p>Use paper that falls within the recommended range. ☞ p.15</p>
	<p>The position of the Paper Feed Pressure Adjustment Lever was inappropriate.</p>	<p>When using thick or slippery paper, set the Paper Feed Pressure Adjustment Lever to CARD (). ☞ p.33</p>
	<p>The angle of the Stripper Plate is inappropriate.</p>	<p>Turn the Stripper Plate Angle Adjustment dial as follows;</p> <ul style="list-style-type: none"> • When the feeding skips Turn the dial to the left.  <ul style="list-style-type: none"> • When multiple sheets are fed Turn the dial to the right.  <p>Important!:</p> <ul style="list-style-type: none"> • Before making the adjustment, be sure to remove all paper from the Paper Feed Tray and confirm that the tray has lowered to the bottom.
	<p>The Paper Feed Adjustment on the Functions screen is not properly set.</p>	<p>Adjust the “Paper Feed Adj.”. Contact your dealer (or authorized service representative) for details on making the adjustment.</p>
<p>The back of the printed card is peeling, or the leading edge gets wrinkled.</p>	<p>The angle of the Stripper Plate is in appropriate</p>	<p>Turn the Stripper Plate Angle Adjustment Dial to adjust the angle.</p>
<p>An error message displays even though there is no paper jam.</p>	<p>Is the lifted paper getting ejected at the second rotation of the Print Drum (Cylinder)?</p>	<p>Check the printed copy, and if the top margin is less than 5 mm ($3/16$"), slightly lower Print Position.</p>
	<p>Is sunlight directly hitting the machine?</p>	<p>The sensor is affected by direct sunlight. Install shades or curtains, or move the machine out of direct sunlight.</p>

Problem	Possible Cause	Action
When printing a multiple page computer file, the machine repeats the master-making process one page at a time.	Is "Collate" option selected in the Printer Driver?	Delete the current print job. Deselect "Collate", and resend the data to the machine. See p.44 , step 3. p.49
The computer sent the file, but it was not received by the machine.	Is the Admin. screen currently showing on the display?	Touch  and switch to the Basic Screen from the Admin. screen.
The  key is blinking.	Received data is waiting for output?	Press the  key and proceed to print.

Appendix

Optional Accessories

A variety of optional accessories are available to enhance the capabilities of the machine. For details about the optional accessories, see your dealer (or authorized service representative).

◆ Auto Document Feeder AF-VI:II

Feed up to 50 sheets of originals automatically.

◆ Color Drum (Cylinder)

Simply change the Drum (Cylinder) to print in multiple colors (colours). (Case included)

◆ A4 (Letter) Drum (Cylinder) W

A special drum (cylinder) for A4 or Letter size landscape paper. (Case included)

◆ Wide Stacking Tray

This unit can take paper up to 340 mm × 555 mm (13³/₈" × 21²⁷/₃₂" in size.

◆ Key Card Counter

With a single button press, shows the numbers of printed copies and consumed masters within a given period of time. This can help you manage costs.

◆ Job Separator

With the Programed Printing function, allows the machine to print and sort into groups separated by tape.

◆ Sorter TM2500

The sorters should be directly connected to the machine. TM2500 can sort 25 copies at maximum.

◆ Document Storage Card DM-128CF

A Storage Card for using the Storage Memory function.

◆ Card Feed kit

This unit allows you to feed thicker paper such as cards.

◆ Envelope Feed Kit

This unit allows you to feed envelopes.

◆ Stand

◆ Ink/Master Holder

A rack kit for storing supply such as ink and masters.

◆ RISO Network Card

Use to directly connect the machine to the network.

This comes with the RISO-MONITOR software that allows you to check the status of the machine from computers.

Specifications

RISO EZ590

Master-making/printing methods	High-speed digital master-making/full automatic stencil printing
Original Type	Book (10 kg (22 lb) or less), sheet
Original Size (max./min.)	When using the Glass Platen : 50 mm × 90 mm (1 ³¹ / ₃₂ " × 3 ⁹ / ₁₆ ") - 280 mm × 432 mm (11" × 17") When using the Auto Document Feeder AF-VI:II : 100 mm × 148 mm (3 ¹⁵ / ₁₆ " × 5 ²⁷ / ₃₂ ") - 310 mm × 432 mm (12 ³ / ₁₆ " × 17")
Original Paper Weight	When using the Glass Platen : 10 kg (22 lb) or less When using the Auto Document Feeder AF-VI:II : 50 g/m ² (14-lb bond) - 128 g/m ² (34-lb bond)
Print Paper Size (max./min.)	100 mm × 148 mm (3 ¹⁵ / ₁₆ " × 5 ²⁷ / ₃₂ ") - 310 mm × 432 mm (12 ³ / ₁₆ " × 17")
Paper Supply Capacity	1000 sheets (64 g/m ² (17-lb bond))
Print Paper Weight	46 g/m ² (13-lb bond) - 210 g/m ² (110-lb index)
Image Processing mode	Line, Photo (Standard/Portrait/Group), Duo (Line/Photo/Shadow off), Pencil (Darker/Lighter)
Master-making Time	Approx. 20 seconds (for A4/landscape/100% reproduction ratio)
Printing Area (max.)	291 mm × 425 mm (11 ⁷ / ₁₆ " × 16 ³ / ₄ ")
Print Reproduction Ratio	Zoom : 50 - 200% Standard reproduction ratio (enlargement) : 200%, 154%, 129%, 121% Standard reproduction ratio (reduction) : 78%, 65%, 61%, 50% Margin+ : 90 - 99 %
Print Speed	Approx. 60 - 130 pages per minute (five steps variable)
Print Position Adjustment	Vertical : ±15 mm (±1 ⁹ / ₃₂ ") Horizontal : ±10 mm (± ³ / ₈ ")
Ink Supply	Full automatic (1000 ml per cartridge)
Master Supply/Disposal	Full automatic (approx. 215 sheets per roll)
Master Disposal Capacity	100 sheets
User Interface	LCD Touch Panel with Progress Arrow indicators, front-side operation
Optional Accessories	Auto Document Feeder AF-VI:II, Color Drum (Cylinder), A4 (Letter) Drum (Cylinder) W, Wide Stacking Tray, Key Card Counter, Job Separator, Sorter TM2500, Document Storage Card DM-128CF, Card Feed kit, Envelope Feed Kit, Stand, Ink/Master Holder, RISO Network Card
Power Source	EZ590U : 100-120/220-240V~, 50-60Hz<3.4A/1.6A>
Dimensions	When in use : 1380 mm(W) × 645 mm(D) × 660 mm(H) (54 ⁵ / ₁₆ "(W) × 25 ³ / ₈ "(D) × 26"(H)) When in storage : 775 mm(W) × 645 mm(D) × 660 mm(H) (30 ¹⁷ / ₃₂ "(W) × 25 ³ / ₈ "(D) × 26"(H))
Weight	Approx. 103 kg (227 lb)

Note:

- Please note that due to improvements and changes to the machine, some images and explanations in this manual may not correspond to your machine.
- The specifications are subject to change without prior notice.

RISO EZ570

Master-making/printing methods	High-speed digital master-making/full automatic stencil printing
Original Type	Book (10 kg (22 lb) or less), sheet
Original Size (max./min.)	When using the Glass Platen : 50 mm × 90 mm (1 ³¹ / ₃₂ " × 3 ⁹ / ₁₆ ") - 297 mm × 420 mm (11 ¹¹ / ₁₆ " × 16 ¹⁷ / ₃₂ ") When using the Auto Document Feeder AF-VI:II : 100 mm × 148 mm (3 ¹⁵ / ₁₆ " × 5 ²⁷ / ₃₂ ") - 310 mm × 432 mm (12 ³ / ₁₆ " × 17")
Original Paper Weight	When using the Glass Platen : 10 kg (22 lb) or less When using the Auto Document Feeder AF-VI:II : 50 g/m ² (14-lb bond) - 128 g/m ² (34-lb bond)
Print Paper Size (max./min.)	100 mm × 148 mm (3 ¹⁵ / ₁₆ " × 5 ²⁷ / ₃₂ ") - 310 mm × 432 mm (12 ³ / ₁₆ " × 17")
Paper Supply Capacity	1000 sheets (64 g/m ² (17-lb bond))
Print Paper Weight	46g/m ² (13-lb bond) - 210g/m ² (110-lb index)
Image Processing mode	Line, Photo (Standard/Portrait/Group), Duo (Line/Photo/Shadow off), Pencil (Darker/Lighter)
Master-making Time	Approx. 20 seconds (for A4/landscape/100% reproduction ratio)
Printing Area (max.)	291 mm × 413 mm (11 ⁷ / ₁₆ " × 16 ¹ / ₄ ")
Print Reproduction Ratio	Zoom : 50 - 200% Standard reproduction ratio (enlargement) : 163%, 141%, 122%, 116% Standard reproduction ratio (reduction) : 87%, 82%, 71%, 61% Margin+ : 90 - 99 %
Print Speed	Approx. 60 - 130 pages per minute (five steps variable)
Print Position Adjustment	Vertical : ±15 mm (± ¹⁹ / ₃₂ ") Horizontal : ±10 mm (± ³ / ₈ ")
Ink Supply	Full automatic (1000 ml per cartridge)
Master Supply/Disposal	Full automatic (approx. 220 sheets per roll)
Master Disposal Capacity	100 sheets
User Interface	LCD Touch Panel with Progress Arrow indicators, front-side operation
Optional Accessories	Auto Document Feeder AF-VI:II, Color Drum (Cylinder), A4 (Letter) Drum (Cylinder) W, Wide Stacking Tray, Key Card Counter, Job Separator, Sorter TM2500, Document Storage Card DM-128CF, Card Feed kit, Envelope Feed Kit, Stand, Ink/Master Holder, RISO Network Card
Power Source	EZ570E, EZ570A, EZ570AN: 100-120/220-240V~,50-60Hz<3.4A/1.6A>
Dimensions	When in use : 1380 mm(W) × 645 mm(D) × 660 mm(H) (54 ⁵ / ₁₆ "(W) × 25 ³ / ₈ "(D) × 26"(H)) When in storage : 775 mm(W) × 645 mm(D) × 660 mm(H) (30 ¹⁷ / ₃₂ "(W) × 25 ³ / ₈ "(D) × 26"(H))
Weight	Approx. 103 kg (227 lb)

Note:

- Please note that due to improvements and changes to the machine, some images and explanations in this manual may not correspond to your machine.
- The specifications are subject to change without prior notice.

Index

Symbols

* Key	22
+ Key	22
× Key	22

Numerics

2 Up	65, 66, 70
------------	------------

A

A4 (Letter) Drum (Cylinder) W	244
Adding Paper	34
ADF Original Guide	20
ADF Original Receiving Tray	20
ADF Original Release Dial	224
ADF Original Release Lever	20, 224
ADF Semi-Auto	150, 163
ADF unit	17, 20, 38, 150, 216
Admin.	161
Admin. Screen	27
Advanced Features	104
Appendix	244
Auto	56
Auto Clear	165
Auto Document Feeder	20
Auto Document Feeder AF-VI:II	244
Auto Idling	40, 166
Auto Page Renewal	147, 149, 166
Auto Power-OFF	165
Auto Print	29, 51
Auto Process Mode	163
Auto Process OFF	51
Auto Sleep	165
Auto-Process	61
Auto-Process Indicator	61
Auto-Process Key	23, 61

B

Base IP Address	164
Basic Process	30
Basic Screen Layout	28
Beep Sound	167
Blocked	28
Book Shadow	77
Buttons on Touch Screen	29

C

C Key	22
Cancel Job	126
Card Feed Kit	244
Center Position Indicator	90
Changing Administrator/User Registration	117
Changing Output Directions	49
Changing Special Paper Ctrl setting	102
Changing Stored Program	135
Changing the Data Order	194
Changing the Owner Name	187

Checking Remaining Consumable Amount	200
CI Select	164
Cleaning	214
Clear All	29, 49, 50
Clearing All User Counters	123
Clearing Job Memory	143
Clearing Program	134
Clearing Special Paper Ctrl setting	103
Clearing User Registration	119
Clock/Calendar	165
Closing the Paper Feed Tray	34
Closing the Paper Receiving Tray	36
Color Drum (Cylinder)	209, 244
Computer Connection	13
Confidential	124
Configurable Functions	161
Connection Method	13
Connector	210
Consumable Errors	218, 221
Consumable Information Screen	232
Consumables	12, 200
Contrast	54
Control Panel	20, 22
Copying Stored Data	197
Counter	21
Counter Report	155
Create User	106, 166
Custom Paper Entry	164, 174
Custom-Sized Paper	60, 174, 177

D

Data Information	186
Data Order	194
Data-Map	28
Default Folder	164
Default Settings	161, 168
Density (print density)	89
Direct Access	171
Direct Access Area	28, 171
Direct Access Entry	161, 171
Direct Print	43
Disable	116
Disabling User identification Access	116
Display	20, 22, 24
Display Adjustment	162
Display Language	162
Display Priority	161
Disposing of Consumables	212
Document Storage Card DM-128CF	244
Dot Process	62
Duo	52
Duo (Line)	52
Duo (Photo)	52
Duo (Shadow off)	53

- E**
- E-mail 154, 155
 - Energy Saving Mode 165
 - Enlarging/reducing 71
 - Enlarging/Reducing Originals 55
 - Entering Master Information 233
 - Entering sizes and changing names 174
 - Entering the User Name 113
 - Envelope Feed Kit 244
 - Error 28
 - Error Messages 218
 - Ex. Reserve Period 145, 165
 - Extended Paper 176
- F**
- Feed Tray Ascent/Descent Button 20, 34, 91
 - Feed Tray Paper Guides 20, 32
 - Fixed Scan Size 164
 - Flanges 203
 - Folder Renaming 164
 - Format 188
 - Free 55, 58
 - Front Cover 21
 - Function and Name of Each Part 20
 - Functions Area 28
 - Functions Descriptions 9
 - Functions Screen 27
- G**
- Gauge Cover 38
 - Glass Platen 17, 20, 38, 215
 - Go to Next 126
 - Group 114, 125
- H**
- High/Full Management 104, 105
 - Horizontal (Left/Right) Adjustment 91
 - Horizontal Print Position Adjustment Dial 20, 91
 - Humidity range 11
- I**
- i Information 28, 201
 - Icons Used in This Manual 8
 - ID Counter Report 154
 - ID Print 45
 - ID Print Job 190
 - Idle 28
 - Idling Action 146
 - Image 52
 - Image Processing 52, 163
 - Initial Screen 24, 37
 - Ink 205, 212
 - Ink Cartridge 21, 205, 212
 - Ink Cartridge Cap Holder 21, 206
 - Ink Handling 12
 - Ink Information Input 232
 - Ink Saving 64
 - Ink/Master Holder 244
 - Installation 10
 - Installation Errors 218, 222
 - Installation location 10
 - Installing the Print Drum (Cylinder) 211
 - Interval 93
- J**
- Job 29
 - Job List Screen 45
 - Job Memory 136, 137, 139, 141, 143
 - Job Operation Area 29
 - Job Properties Area 29
 - Job Separation 163
 - Job Separator 126, 244
 - Jump Wing Control 95, 96, 164
- K**
- Key Card Counter 244
- L**
- Limit 115
 - Line 52
 - Log out Key 23
 - Loop 26
 - Low/Admin tab only 104, 105
- M**
- Machine Handling 11
 - Maintenance 214
 - Maintenance Call 226
 - Malfunctions 235
 - Management Level 104, 105, 109, 166
 - Manual 45
 - Margin 18, 69
 - Margin+ 55, 56
 - Margin-Plus Rate 164
 - Master 213
 - Master core 203, 212
 - Master Disposal Box 20, 207
 - Master Disposal Box Handle 207
 - Master Disposal Box Lever 207
 - Master Guide Flap 21, 203
 - Master Information Input 233
 - Master Jam Errors 218, 219
 - Master Making Unit 21, 202
 - Master Making Unit Cover 21, 202
 - Master Making Unit Cover Lever 202
 - Master Making Unit Handle 21, 202
 - Master Making Unit Release Button 21, 202
 - Master Removal Hook 216, 225
 - Master Replacement 202
 - Master Roll 21
 - Master Roll Holder 21, 203
 - Master-Making Key 23
 - Materials Not to Be Printed 18
 - Max. Scan 86

Maximum Printing Areas	18	Paper Jumping Wing	21, 95
Message	218	Paper Receiving Tray	21, 35, 36
Meter Display	152	Paper Recommendations	15
Metric/Inch Switch	162	Paper Stopper	21, 35, 36
Mid/ID Print Only	104, 105	Pause	28
Minimum Print Q'ty	166	Pencil	52
MODE Key	22, 26	Pencil (Darker)	53
Mode Key Pattern	161	Pencil (Lighter)	53
Mode Screen	25	Photo	52
Mode Selection	26	Photo (Group)	52
Monthly Reminder	156	Photo (Portrait)	52
Moving Stored Data	197	Photo (Standard)	52
Multi-Page Mode	126, 128	PIN code	105, 107, 111, 168
Multiple-Original	65	PIN code Input Screen	26, 38, 42
Multi-Up function	65	Platen Cover	20
Multi-Up Interval	69, 165	Platen Cover Pad	20, 215
Multi-Up Print	65, 66, 72	Pop-Up Message	226
Multi-Up Tickets	65, 68, 74	Power connection	10
My Counter	200	Power Switch	21, 32
My Direct Access	158	Power-OFF Schedule	165
N		Pressure Roller	216
Next Page	126	Preview	29, 49, 83
Non-ID Print	190	Print	154, 155
O		Print Basic Screen	25
OP Auto Process	163	Print Colors (Colours)	167
Operation Environment	11	Print Density	22, 89, 163
Operation flow of User Management	106	Print Density Adjustment	89
Operation Safety Guide	11	Print Density Adjustment Indicator	22, 89
Operational Instructions	9	Print Density Adjustment Keys	22, 89
Option	244	Print Drum (Cylinder)	21, 209, 211
Optional Device Area	29	Print Drum (Cylinder) Handle	21, 209
Optional Device Errors	218, 220	Print Drum (Cylinder) Release Button	21, 209
Orientation of Print Paper	69	Print Drum (Cylinder) Replacement	209
Original	17	Print Key	23
Original Margin	18	Print Paper	15
Original Orientation and Print Results	66	Print Paper Handling	16
Original Scan Density	54	Print Paper Setting	32
Output method	154	Print Position	22
Outputting the Counter Report	154	Print Position Adjustment	22, 90
Overlay	195	Print Position Center Key	90
Overlaying Stored Data	196	Print Quantity Display	22, 92
Owner Name	187	Print Quantity Keys (0 to 9 Keys)	22
P		Print Speed	22, 88, 163
P Key	22	Print Speed Adjustment	88
Page Orientation	167	Print Speed Adjustment Indicator	22, 88
Paper	60	Print Speed Adjustment Keys	22, 88
Paper Arranger	21, 35, 36	Printer Exterior	217
Paper Button	29	Printing from Computer	29, 30, 43
Paper Eject Adj.	95	Printing from Paper Document	28, 30, 37
Paper Ejection Adj	164	Printing from USB Flash Drive	30
Paper Feed Adj.	95	Program	125, 129, 130, 132, 134, 135
Paper Feed Pressure Adjustment Lever	20, 33	Program Print	126, 127
Paper Feed Tray	20, 32	Progress Arrows	23
Paper Jam Errors	218, 224	Proof	92
		Proof copy	92
		Proof Key	23, 92

- Protect 166, 178, 179
 Push Out Lever 207
- R**
- Receiving Tray Paper Guides 21, 35, 36
 Recognition and Identification System 107
 Recognition Screen 26, 42
 Recognized by 105, 107, 111, 166, 168
 Registering Administrator/Users 110
 Reminder Date 154
 Removing the Print Drum (Cylinder) 209
 Rename 113, 132
 Rename Group 106, 121, 166
 Rename screen 133
 Renaming a Job Memory 139
 Renaming a Program 132
 Renew Page 29, 126, 147
 Replacing Batteries 219, 226
 Replacing Consumables 200
 Replacing Paper 34
 Reproduction Size 163
 Reservation 145
 Reserve Period 165
 Reset Counter 106, 123, 166
 Reset Key 23
 Retrieving a Job Memory 141
 Retrieving a Program 129
 Retrieving Special Paper Ctrl 97
 Retrieving Stored Data 189
 RISO COPY COUNT VIEWER 14
 RISO Network Card 244
 RISO Print 25
 RISO Printer Driver 14
 RISO USB PRINT MANAGER 14
 RISO Utility Software 14
 Rotate 148, 153
- S**
- Safety Guide 10
 Saving Programs 130
 Saving Special Paper Ctrl 99
 Scan Basic Screen 26
 Scan Mode 184
 Scanner Glass 216
 Scanning 26
 Scanning Contrast 54, 163
 Screens and their Various Stages 24
 Selections 171
 Selections Entry 161, 171
 Selections Screen 27, 171
 Selections Tab 171
 Semi-Auto (Master) 45, 51
 Semi-Auto (Print) 44, 51
 Separation Hook 216, 225
 Service Call Errors 218, 219
 Setting Data Information 186
- Setting the Group to assign 114
 Setting the Management Level 109
 Setting the Paper Receiving Tray 35
 Setting the User's Usage 115
 Setting Up for Programed Printing 127
 Setting Up the Monthly Reminder 156
 Side Margin 81
 Single Page Mode 125, 127
 Single-Original 65
 Size and Weight Restrictions 15, 17
 Skip Page 29, 49
 Software Installation 14
 Sorter TM2500 244
 Special Paper Ctrl 95, 97, 99, 102, 103
 Specifications 245
 Specifying Stored Size 188
 Speed (print speed) 88
 Stabilizer 21
 Stand 244
 Standard Ratio 55, 56
 Start Key 23
 Start-Up Screen 24, 162
 Status Area 28, 29
 Stock Management 166
 Stop Key 23
 Stop Timing 51
 Storage Memory 189
 Storage Retrieve Screen 192
 Storing Environment 16
 Storing Job Memory 137
 Storing Original Data 182
 Sub Tool Bar 167
- T**
- Tab Area 28, 29
 Temperature range 11
 Text and Photo (Image Processing mode) 52
 Text (Image Processing mode) 52
 Thermal Print Head 21, 215
 Tips for Better Paper Feeding 16
 Tool Bar Position 167
 Top Margin 79
 Troubleshooting 218, 235
- U**
- Usage Status 152
 USB Flash Drive ... 11, 105, 107, 111, 154, 155, 168
 USB Flash Drive Screen 26, 38, 42
 USB Job List 43, 46, 189
 USB Job List Retrieve Screen 192
 USB slot 21, 47
 User Counter 123
 User identification access 105, 116
 User Management 104, 166
 User Name 113
 User Registration Number (ID) 110

Index

User's Usage 115

V

Vertical Print Position Adjustment Keys 22, 90

Vertical (Up/Down) Adjustment 90

W

WAKE-UP Key 23, 37, 46

Warning Messages 227

White Sheet 216

Wide Stacking Tray 244

Z

Zoom 55, 59

To Administrator

Canceling the Protect Setting

Cancellation of the “Protect” setting should be always done by the administrator.

Important!:

- To attach more importance to security, cut out this page, which should be stored by the administrator.

1 Touch [Admin.] on the Basic Screen for each mode.

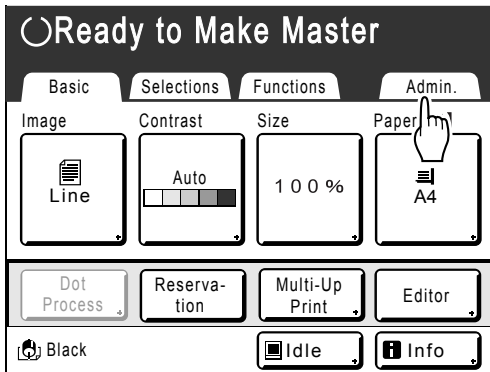

2 Touch [OK].

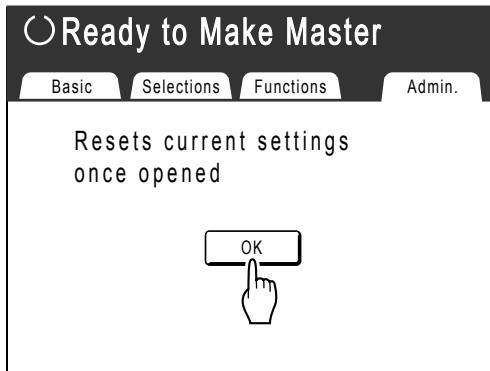

If the Recognition Screen is displayed, follow the message on the screen. See step 2 in “Customizing the Default Settings”. (p.168)

3 Touch [Protect].

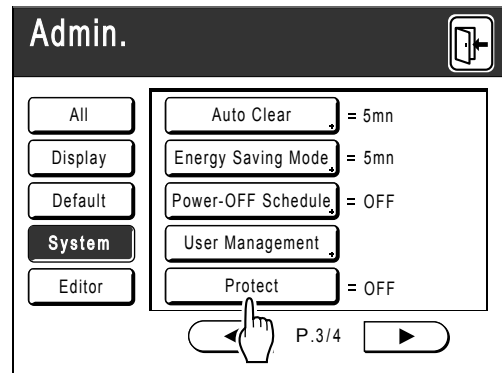

After displaying the message “Please Wait a Moment”, the protect setting is canceled.

