

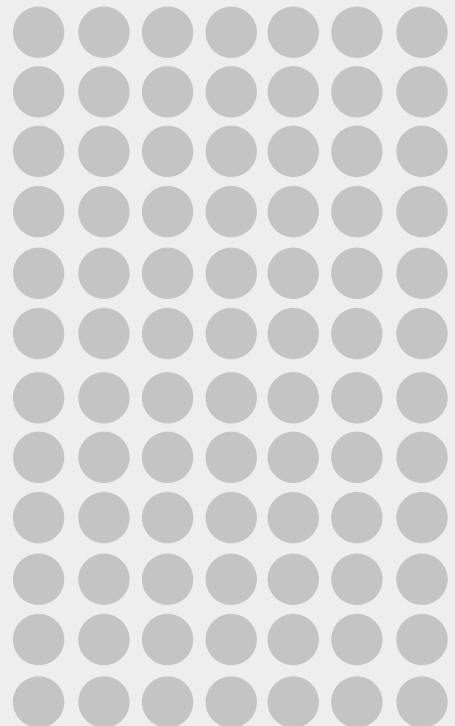

SORTER TM2500

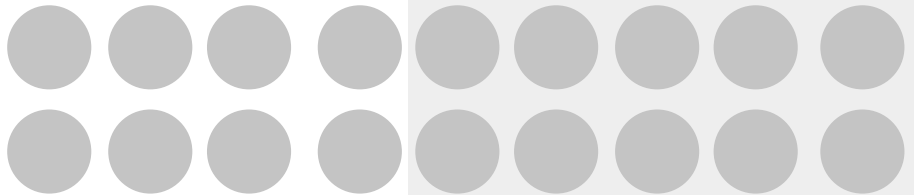

RISO MAKES NO WARRANTY OF ANY KIND WITH REGARD TO THIS USER'S GUIDE, INCLUDING, BUT NOT LIMITED TO, THE IMPLIED WARRANTIES OF MERCHANTABILITY AND FITNESS FOR A PARTICULAR PURPOSE. RISO SHALL NOT BE LIABLE FOR ERRORS CONTAINED HEREIN OR FOR INCIDENTAL OR CONSEQUENTIAL DAMAGES IN CONNECTION WITH THE FURNISHING, PERFORMANCE OR USE OF THIS USER'S GUIDE. RISO ASSUMES NO LIABILITY FOR DAMAGES RESULTING FROM THE USE OF THE INFORMATION CONTAINED HEREIN.

FCC Warning

This equipment has been tested and found to comply with the limits for a Class A digital device, pursuant to Part 15 of the FCC Rules. These limits are designed to provide reasonable protection against harmful interference when the equipment is operated in a commercial environment. This equipment generates, uses, and can radiate radio frequency energy and, if not installed and used in accordance with the instruction manual, may cause harmful interference to radio communications. Operation of this equipment in a residential area is likely to cause harmful interference, in which case the user will be required to correct the interference at his own expense.

CONTENTS

Welcome to the RISOgraph Sorter TM2500	3
About This User's Guide	3
Cautions in Installation and Operation	4
Location and Environment	4
Power Connections	5
Handling and Operation	5
Knowing the Parts and Components	6
The Control Panel.....	7
Paper Recommendations	8
Size and Weight Restrictions	8
Description of Job Modes	9
Sort Mode.....	9
Stack Mode	9
NonSort Mode.....	9
Basic Operation.....	10
Using the Stapler.....	14
Advice Displays on the Stapler	14
Refilling the Staple Cartridge	15
Removing Jammed Staples	17
Troubleshooting Tips	18
Advice Displays.....	18
Disconnecting the Sorter from the Printer	19
Specifications	20
Index	21

Welcome to the RISOgraph Sorter TM2500

Thank you for purchasing the RISOgraph Sorter TM2500, whose compact body enables itself to stand beside your printer like its component and satisfy your small-volume finishing needs. It also prevents unexpected ink smudges on the rear side of printed copies. To allow you to produce booklets beside your printer, besides, it is equipped with a motor-driven stapler as standard.

About This User's Guide

This Guide provides all the information you need to use your RISOgraph Sorter TM2500. It is designed to help you take advantage of the features built into the RISOgraph Sorter TM2500 and provides information on its operations, precautions and troubleshooting.

Be sure to read this Guide before you start using the sorter. Also be sure to refer to this Guide whenever you are uncertain about any operation you wish to perform.

Safety Remark

Gives you safety instructions under the following icons:

WARNING

Ignoring these instructions could cause serious injury.

Caution

Ignoring these instructions could cause injury or damage to the equipment.

Operation Instruction

Describes operation procedures with simple numbered step.

Advice Remark

Gives you helpful advice for trouble-free operation under the following headings:

Important!

Provides important information on installation and operation

NOTE

Provides additional information for utility.

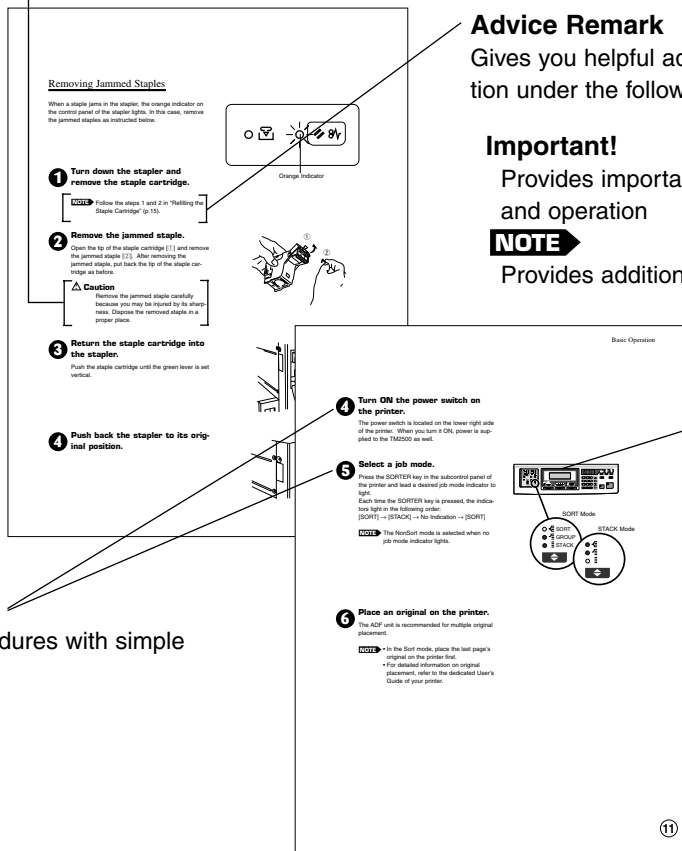

Removing Jammed Staples

When a staple jams in the stapler, the orange indicator on the control panel of the stapler lights. In this case, remove the jammed staple as instructed below.

- 1 Turn down the stapler and remove the staple cartridge.**
Follow the steps 1 and 2 in "Refilling the Staple Cartridge" (p.15).
- 2 Remove the jammed staple.**
Open the tip of the staple cartridge [1] and remove the jammed staple [2]. After removing the jammed staple, put back the tip of the staple cartridge as before.
Caution Remove the jammed staple carefully because you may be injured by its sharp ends. Dispose the removed staple in a proper place.
- 3 Return the staple cartridge into the stapler.**
Push the staple cartridge until the green lever is set vertical.
- 4 Push back the stapler to its original position.**

Basic Operation

- 4 Turn ON the power switch on the printer.**
The power switch is located on the lower right side of the printer. When you turn it ON, power is supplied to the TM2500 as well.
- 5 Select a job mode.**
Press the SORTER key in the subcontrol panel of the printer and lead a desired job mode indicator to light. Each time the SORTER key is pressed, the indicator lights in the following order: [SORT] → [STACK] → No Indication → [SORT].
NOTE The NoSort mode is selected when no job mode indicator lights.
- 6 Place an original on the printer.**
The ADF unit is recommended for multiple original placement.
NOTE In the Sort mode, place the last page's original on the printer first.
* For detailed information on original placement, refer to the dedicated User's Guide of your printer.

Panel Highlight

Indicates the key and/or indicator to be used or referred to during operation.

Cautions in Installation and Operation

Follow the directions below for the proper location and environment when installing and operating your unit. They are intended to increase safety, ensure proper quality and prolong the life of your unit.

Location and Environment

Your dealer will help determine a proper location for your unit at the time of delivery.

WARNING

- **Do not place water containers or metallic objects on the unit. If water drips inside the unit or a metallic object drops inside it, it can result in a fire or an electric shock.**

Caution

- When you relocate the unit, be sure to unplug the power cord from the electrical outlet. Otherwise, it could cause machine failure, a fire, or an electric shock.
- Install the unit near an electrical outlet to avoid using an extension cord between the unit and the electrical outlet. If an extension cord is unavoidable, do not use one longer than 15 ft (5 m).
- Do not allow anything to rest on or roll over the power cord and do not place the unit where the power cord is subject to traffic or abuse. This can result in a shock or fire hazard.
- Do not place heavy objects on the unit. The objects might fall and cause injury.
- Keep the unit away from dusty or humid areas. Otherwise, a fire or an electric shock might occur.

Important!

- Avoid installing the unit in the locations listed below. Failure to observe this precaution may lead to machine failure or human injury.
 - Locations where the unit will not stand level (a maximum differential of $\pm 3/8$ inch (± 10 mm) is allowed).
 - Extremely bright locations such as locations close to windows or locations that are exposed to direct sunlight (provide a curtain if you have no choice to install the unit in such location).
 - Locations that are subject to sudden temperature change.
 - Extremely hot and humid locations or cold and dry locations.
 - Recommended temperature range: 59°F to 86°F (15°C to 30°C) with moderate humidity (40% to 70%, no condensation).
 - Heated locations.
 - Locations exposed to direct cold air from an air conditioner, direct hot air from a stove, or direct radiant heat.
 - Badly ventilated locations.

Power Connections

WARNING

- Check the rating plate on the unit before connecting the power cord to avoid applying the excess voltage to it.
- Use the dedicated power cord.
- Securely insert the power cord plug into the electrical outlet to ensure proper electrical connection.
- Do not overload an electrical outlet or extension cord, nor damage the power cord by placing heavy objects on it or pulling or bending it. Otherwise, a fire or an electric shock might occur.
- Do not plug or unplug the power cord with wet hands. Otherwise, an electric shock might occur.

Caution

- Do not pull the power cord but hold the plug itself when unplugging it. Otherwise, it could become damaged and a fire or an electric shock might occur.

Handling and Operation

WARNING

- Do not insert or drop any metallic material or flammable substance into the unit through any opening. Otherwise, a fire or an electric shock might occur.
- Do not remove the unit covers because the unit contains the high-voltage parts, which might give you an electrical shock if you touch them.
- Do not disassemble or rebuild the unit by yourself. Otherwise, a fire or an electric shock might occur.
- If the unit gets uncomfortably hot, smokes or smells bad, immediately turn off the power, unplug the power cord and contact your service representative because a fire or an electric shock might occur.
- If something drops inside the unit, turn off the power switch first, then unplug the power cord and contact your service representative. If you continue using it, a fire or an electric shock might occur.
- Unplug the power cord if you think there is an electrical problem or you do not use the unit for a long time.
- Keep loose clothing or long hair away from moving parts to avoid becoming entangled.

Caution

- Do not turn off or unplug the unit during operation.
- Do not open the cover or move the unit during operation.
- Do not try to alter the unit or remove parts.
- Open and close the cover gently.
- Do not subject the unit to jolts.
- Never stick your hands or fingers in the opening around the Precision Stacking Tray, as well as the Joint Unit during operation. Also, do not stick your hands or fingers in the opening of the stapler.
- The unit contains precision parts and driving mechanism. Do not attempt to perform an operation other than those given in the User's Guide.
- Contact your service representative when the unit is to be relocated.

Knowing the Parts and Components

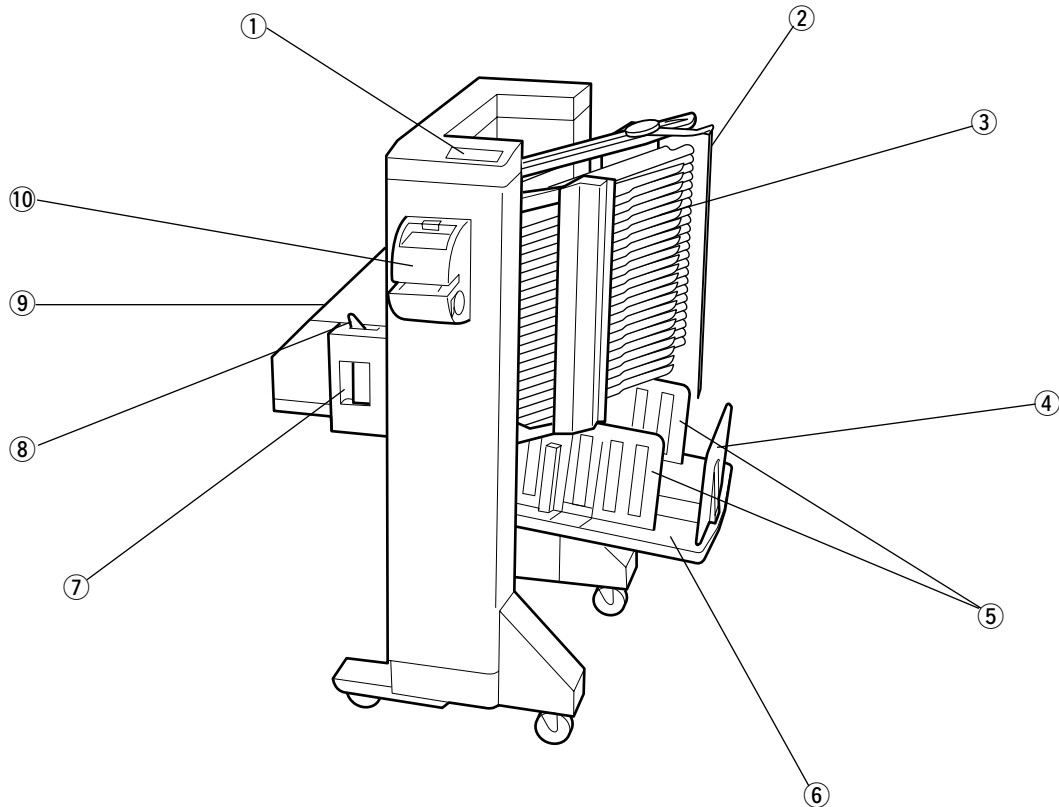

- ① **Control Panel** (☞ p.7)
Gives various job directions through key entry and shows various advices on the display.
- ② **Bin Paper Stopper** (☞ p.10)
Stops the sheets ejected into the bins for their neat arrangement.
- ③ **Bin**
Receives distributed sheets. 25 bins are available.
- ④ **Tray Paper Stopper** (☞ p.10)
Stops the sheets ejected into the NonSort Precision Stacking Tray.
- ⑤ **Tray Paper Guides** (☞ p.10)
Aligns the sheets ejected into the NonSort Precision Stacking Tray neatly.
- ⑥ **NonSort Precision Stacking Tray** (☞ p.10, 12)
Receives ejected sheets in the NonSort Mode. Receives the initial sample copy and excess sheets in other job modes.
- ⑦ **Joint Unit Release Lever**(☞ p.19)
Releases the lock of the Joint Unit on the printer.
- ⑧ **Bin Paper Ejection Guide Adjustment Lever** (☞ p.10)
Adjusts the position of the Bin Paper Ejection Guides according to the paper to be used.
- ⑨ **Joint Unit** (☞ p.19)
Receives the printed copies that are ejected from the printer and ejects them into the tray and bins.
- ⑩ **Stapler**(☞ p.14)
Automatically staples inserted sheets.

The Control Panel

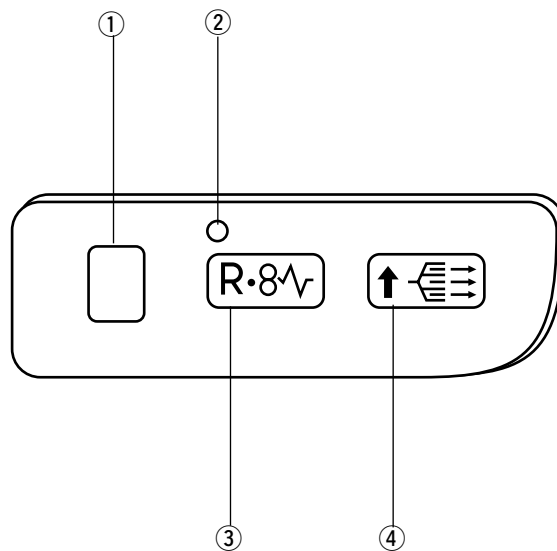

① **Status Display** (☞ p.18)

Shows the current operation status.

0: idle

1: in operation

Also shows error status when a trouble occurs.

② **Error Indicator (Red)**

Lights when a trouble occurs.

③ **Reset Key**

Resumes operation after a trouble is cleared. Operation is automatically resumed in case of recovery from paper jam error.

④ **Bin Elevation Key** (☞ p.12)

Raises the bins to allow easy collection of sheets stacked in bins.

Paper Recommendations

Important!

Using unsuitable paper could lead to paper jams, machine troubles, or ink smudges on printed copies. Regarding unsuitable types of paper, refer to the printer's User's Guide.

Size and Weight Restrictions

The allowable paper size range for bins is: 7 x 7 inch (182 mm x 182 mm) to 11 x 17 inch (297 mm x 432 mm).

The allowable paper weight (thickness) range for bins is: 15-lb bond to 36-lb bond (50 to 157 g/m²).

- Refer to the dedicated printer's User's Guide regarding the paper size and thickness available in the NonSort Mode.

Description of Job Modes

The following three job modes are available. Sort, Stack, and NonSort. You can select one of them depending on your finishing needs.

Sort Mode

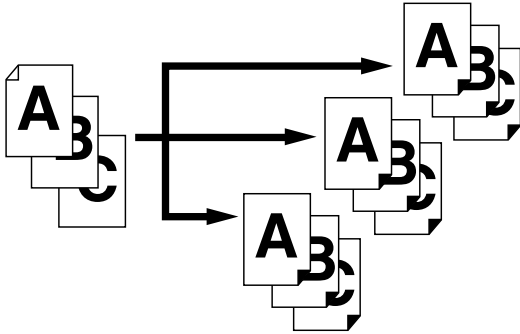

The Sort Mode provides you with multiple sets of multi-page documents, which are stored in separate bins (25 bins) through orderly distribution of copies printed from multiple originals.

You can have a desired number of multi-page booklets (up to 25 sets) if you use the motor-driven stapler provided, collecting stacks of sheets from each bin.

NOTE Printed copies are distributed into the bins, from the bottom to the top.

Important!

If you print more copies per page than the number of bins available, the excess ones are ejected into the NonSort Precision Stacking Tray.

Stack Mode

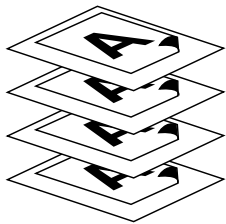

The Stack Mode distributes a large volume of copies printed from a single original into separate bins, by which unexpected ink smudges on print's face can be prevented, provided with sufficient time for ink drying. This mode will be useful, specially for double-sided printing in which ink smudges are less welcome than in single-sided printing.

SPECIAL NOTE Bin capacity

A single bin can contain up to 30 sheets of paper (with 17-lb bond or 64 g/m² paper).

NonSort Mode

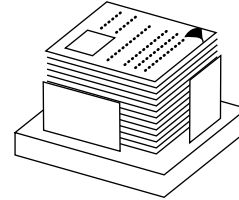

The NonSort Mode stacks all printed copies in the dedicated Tray, the NonSort Precision Stacking Tray, without distributing them into bins. The NonSort Precision Stacking Tray can store approximately 1,000 sheets (17-lb bond or 64 g/m² paper).

This mode will be useful when you print a small volume of copies from a single original.

- NOTE**
- Printed copies are distributed into the bins, from the bottom to the top. When the top bin receives a printed copy, the next copy is distributed into the bottom bin again and this distribution process is repeated until the print job finishes.
 - If another original is printed, a new cycle of stack operation starts from the bottom bin.
 - To secure enough time for ink drying on printed copies with large solids in the Stack mode, you can lead the printer to delay resuming operation after its suspension during which the preparatory operation for the succeeding sequence of sheet distribution proceeds. (See p.13 "Special Note-Providing Stack Mode's Interval")

Basic Operation

1 Adjust the position of the Tray Paper Guides and Stopper on the NonSort Precision Stacking Tray.

Raise the Tray Paper Guides and Stopper, if not, and slide them to fit the paper size.

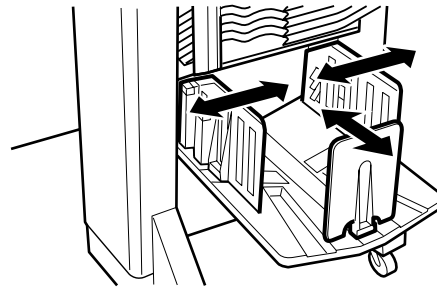

NOTE Set the paper arrangers referring to the instructions given in the dedicated User's Guide of your printer.

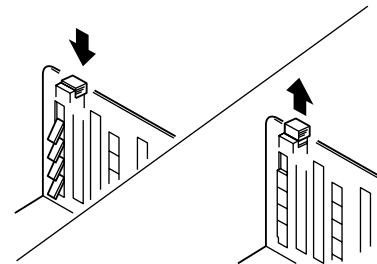

2 Adjust the position of the Bin Paper Stopper to fit the paper length.

Slide the Stopper Base to the corresponding paper size indication along the Stopper guide scale.

NOTE When you select the NonSort Mode, this adjustment is not required.

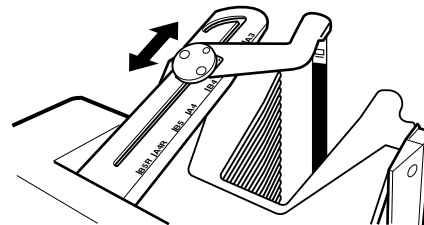

3 Adjust the Bin Paper Ejection Guides.

Position the Bin Paper Ejection Guide Adjustment Lever at either * (Normal) or ≡ (Card), according to the paper to be used.

- * (Normal) Standard paper
- ≡ (Card) Thick paper, such as drawing paper.

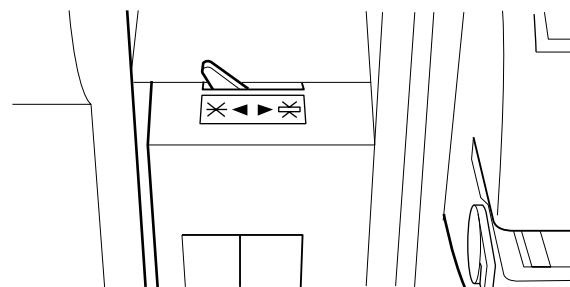

4 Turn ON the power switch on the printer.

The power switch is located on the lower right side of the printer. When you turn it ON, power is supplied to the TM2500 as well.

5 Select a job mode on the control panel of the printer.

6 Place an original on the printer.

The ADF unit is recommended for multiple original placement.

- NOTE**
- In the Sort mode, place the last page's original on the printer first.
 - For detailed information on original placement, refer to the dedicated User's Guide of your printer.

7 Start the selected job from the printer.

Specify the print quantity and press the START key on the printer.

An initial proof copy is ejected to the NonSort Precision Stacking Tray and the operation is interrupted. Press the START key on the printer again to resume operation if you find the proof copy as expected.

- NOTE**
- When the Auto Print feature is activated on the printer, the operation is not interrupted after the initial proof copy.
 - The Test Print key on the control panel of the printer is available whenever the sorter is idle.
 - For a detailed description of printer's operations, refer to its dedicated user's guide.

8 Collect printed copies from bins.

If the bins are not at the high position, press the Bin Elevation key on the control panel. Then collect stacks of printed copies from the bins and/or Non-Sort Precision Stacking Tray.

- NOTE**
- When the NonSort Mode is selected, all printed copies are stacked in the NonSort Precision Stacking Tray.

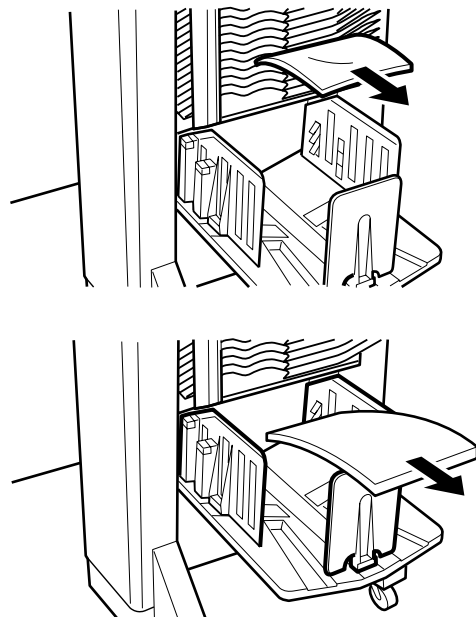
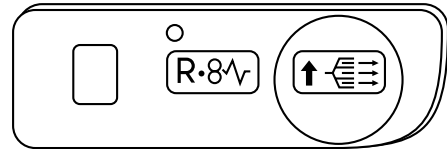

Special Note-Providing Stack Mode's Interval

You can give an interval before the printer resumes operation after its suspension in the Stack Mode to secure enough time for ink drying on printed copies with large solids, preventing unexpected ink smudges on them.

You can select one of the following three different lengths of interval depending on the largeness of solids on printed copies: 5 sec., 10 sec. and 20 sec.

[Interval Selection Procedure]

- ① When “0” is indicated on the Status Display, press the Reset key.

If the Reset key is kept held down, the indication changes in the following order: 1 → 2 → 3 → 0 → 1
(Available intervals)

- 1: 5 seconds
- 2: 10 seconds
- 3: 20 seconds
- <0>: No interval> - default setting

- ② When a desired number is indicated on the Status Display, release the Reset key.

If the selected interval is confirmed, the indication on the Status Display automatically goes back to 0.

If the power is turned off or the All Reset key is pressed on the printer, the selected interval is canceled (no interval is given).

Using the Stapler

The motor-driven stapler is attached as standard equipment, to allow you to staple stacks of sorted copies in the bins.

To activate the stapler, insert a stack of sheets into the slit of the stapler. The inserted stack is then automatically stapled.

This stapler can staple up to 50 sheets of paper together (with 17-lb bond or 64 g/m² paper).

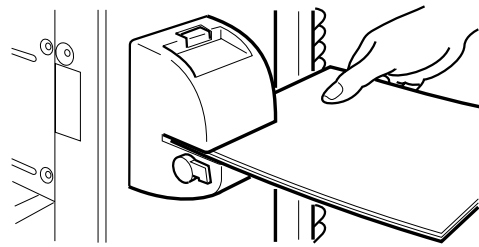

NOTE If you want to staple a stack of sheets slantwise in a corner, set the Slant Corner Stapling Lever at the marked position.

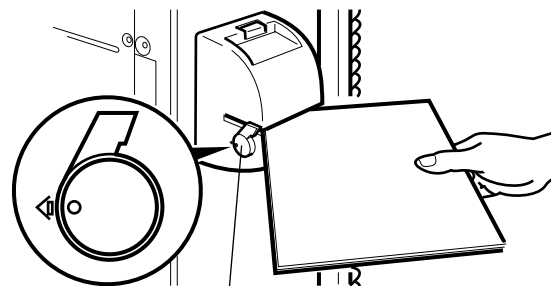

Slant Corner Stapling Lever

Advice Displays on the Stapler

When the green indicator lights;

Cause The stapler has run out of staples.

Action Follow the instructions in "Refilling the Staple Cartridge" (p.15) and charge the staple cartridge with a full staple box.

When the orange indicator lights;

Cause A staple jams inside.

Action Press the Stapler Reset key. Push the PUSH OPEN button. When the green indicator starts flashing, follow the instructions in "Removing Jammed Staples" (p.17) to remove the jammed staple.

When both the green and orange indicators light;

Cause A malfunction has occurred.

Action Hold down the Stapler Reset key for 2 seconds or more or turn the power switch OFF and then ON again on the printer. If this happens frequently, contact your service representative.

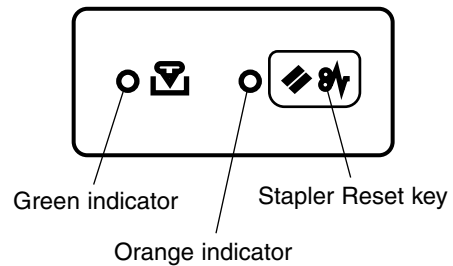

[Turning down the stapler]

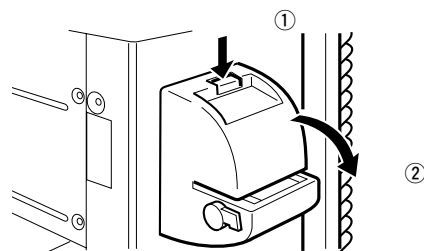

Refilling the Staple Cartridge

When the stapler runs out of staples, the green indicator on the control panel of the stapler lights. In this case, refill the empty cartridge with staples as instructed below.

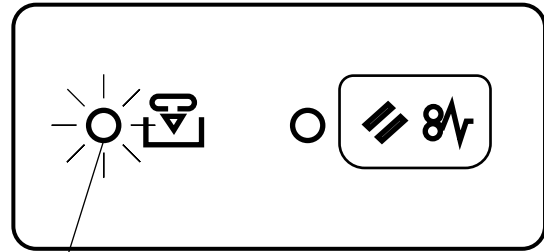

Green Indicator

1 Turn down the stapler.

Press the green (PUSH OPEN) button and pull the stapler toward you.

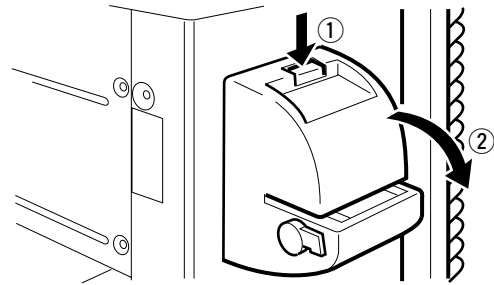

2 Remove the empty staple cartridge.

Pull the green lever toward you and release the cartridge lock. Pull out the empty staple cartridge.

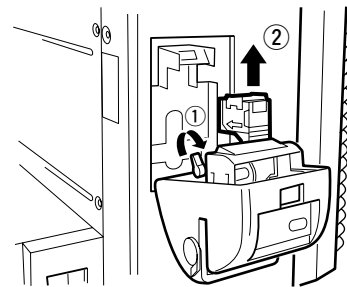

3 Remove the empty staple box from the cartridge.

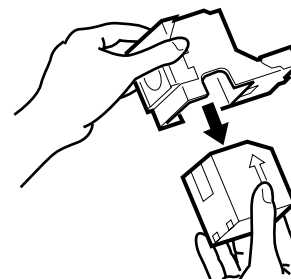

4 Put a new staple box into the cartridge.

Push a new staple box into the cartridge as shown in the figure and pull off the holding tape.

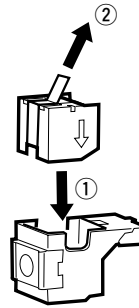

5 Return the charged staple cartridge into the stapler.

Push in the staple cartridge until the green lever is set vertical.

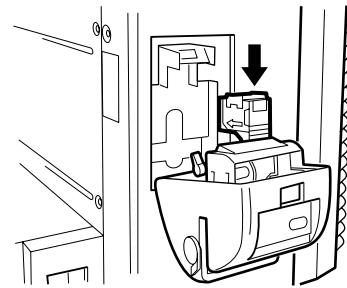

6 Push back the stapler to its original position.

NOTE Recommended staple is: No.500 (3 boxes in each package, each box containing 5000 staples)

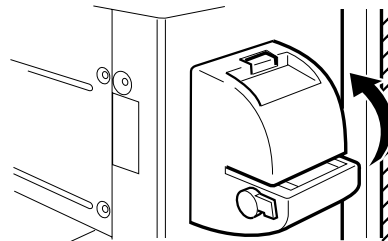

Removing Jammed Staples

When a staple jams in the stapler, the orange indicator on the control panel of the stapler lights. In this case, remove the jammed staples as instructed below.

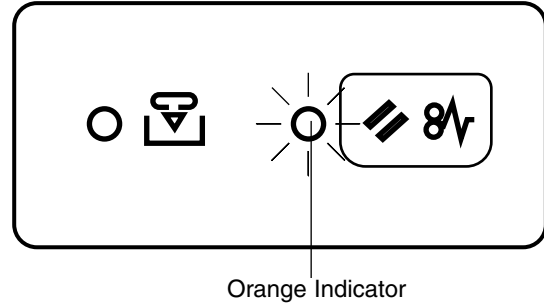

1 Turn down the stapler and remove the staple cartridge.

NOTE Follow the steps 1 and 2 in “Refilling the Staple Cartridge” (p.15).

2 Remove the jammed staple.

Open the tip of the staple cartridge [①] and remove the jammed staple [②]. After removing the jammed staple, put back the tip of the staple cartridge as before.

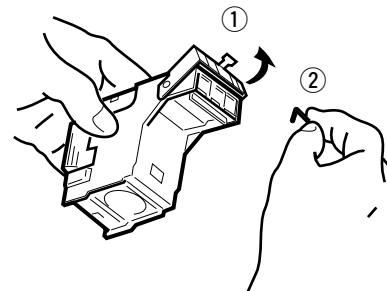

⚠ Caution

Remove the jammed staple carefully because you may be injured by its sharpness. Dispose the removed staple in a proper place.

3 Return the staple cartridge into the stapler.

Push the staple cartridge until the green lever is set vertical.

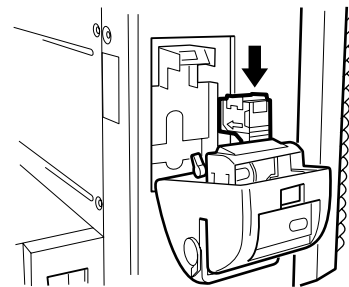

4 Push back the stapler to its original position.

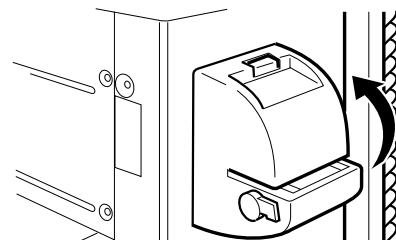

Troubleshooting Tips

Advice Displays

This section explains how to deal with advice displays which may appear on the Status Display of the Control Panel. In case any of the following advice displays appears on the Status Display, take necessary actions referring to the descriptions below.

NOTE Check what is indicated on the control panel of the printer if required.

2.

Cause The sorter is not properly connected to the printer.

Action Push the sorter towards the printer to connect it properly.

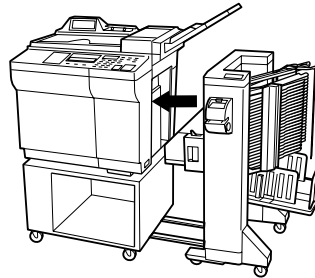

4. 5. 6.

Cause Paper has jammed in the sorter.

Action Check the bins where paper has jammed and remove the jammed paper. Then remove all remaining sheets in the Joint Unit and printer.

(See P.19 "Disconnecting the Sorter from the Printer".)

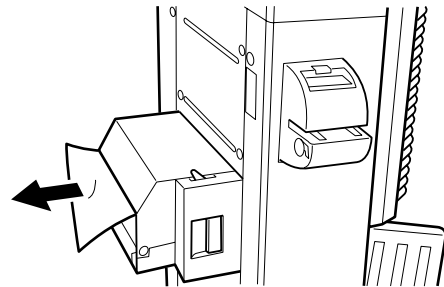

Important!

If the indication on the Status Display does not return to "0" after you remove the jammed paper, press the Reset key on the control panel.

9. A. C. d. E. F.

Cause An error has occurred, interrupting operation.

Action Turn the power OFF and then ON again.

Important!

If this error occurs repeatedly, contact your service representative and give the displayed error code to him/her.

NOTE For the advice displays on the stapler, see page 14.

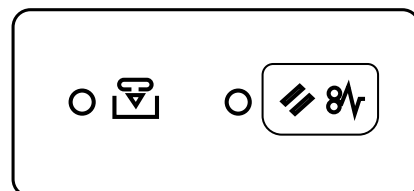
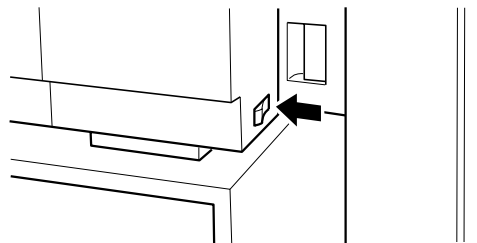

Disconnecting the Sorter from the Printer

1 Grip the Joint Unit Release Lever.

A click sounds and the Joint Unit is unlocked from the printer.

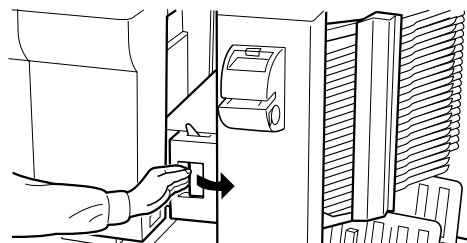

2 Push the sorter off the printer, holding the lever.

The sorter is separated far enough from the printer for you to check the Joint Unit.

Important!
Always push off the sorter straight.

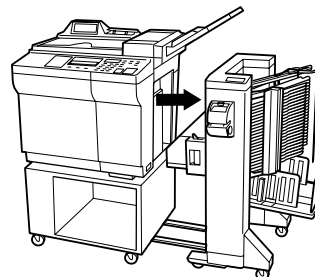

3 To connect the sorter to the printer again, in push back the sorter toward the printer until it stops.

When the sorter is connected properly to the printer, a click sounds.

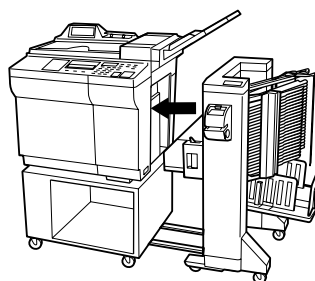

Specifications

System	Shifting open-tray bins with a single NonSort tray installed at bottom [face-up paper transfer]
Job Mode	Sort / Stack / NonSort
Bin Quantity	25 bins with 1 NonSort precision stacking tray [Multiple tower connection is not available]
Bin Capacity	<Sort Bin> Approx. 30 sheets/bin (17-lbs bond paper or 64 g/m ²) or 3.0 mm or less when accumulated <NonSort Precision Stacking Tray> Approx. 1000 sheets (17-lbs bond paper or 64 g/m ²) or 100 mm or less when accumulated
Paper Size	<Sort Bin> Max./ Ledger (11 x 17 inch) or A3 (297 x 420 mm) Min./ 7 x 7 inch or 182 x 182 mm <NonSort Precision Stacking Tray> Max./ Ledger (11 x 17 inch) or A3 (297 x 420 mm) Min./ 4 x 6 inch or A6 (100 x 148) mm
Paper Weight	<Sort Bin> Max./ 36-lb bond or 157 g/m ² Min./ 15-lb bond or 50 g/m ² <NonSort Precision Stacking Tray> Max./ 110-lb index or 209 g/m ² Min./ 15-lb bond or 50 g/m ²
Job Speed	<Sort & Stack Modes> 60 to 80 sheets/min. <NonSort Mode> 60 to 130 sheets/min. (Automatically adjusted to Risograph)
Error Detection Function	6 kinds of operator-recoverable errors to be detected
Attachment	Motor-driven, flat-clinching stapler [Max. 50 sheets (17-lb bond paper or 80 g/m ²) can be stapled] * Equipped with the dedicated 5000-cap. staple cartridge
Machine Weight	Approx. 115 lbs (52kg)
Dimensions [W x D x H]	25.5 x 29.5 x 52.2 inch (648 x 748 x 1,325 mm)
Power Source	220 to 240 VAC, 50/60Hz <1.6 A>
<Requirements>	120 VAC, 60 Hz <2.4 A>

NOTE These specifications are subject to change without prior notice. Please understand that the illustrations and descriptions in this manual may vary from the actual machine due to possible changes in the specifications.

Index

A		
advice displays	18	
B		
basic operation	10	
bin	6, 9, 12	
bin capacity	9	
bin elevation key (illustration)	7	
bin elevation key ,using	12	
bin paper ejection guide adjustment lever	6,10	
bin paper stopper	6,10	
C		
cautions, environment	4	
cautions, handling	5	
cautions, installation	4	
cautions, location	4	
control panel	6, 7	
D		
disconnecting the sorter	19	
E		
error indicator (illustration)	7	
H		
handling, warnings and cautions	5	
J		
jammed staples, removing	17	
job modes	9	
joint unit	6,19	
joint unit release lever	6,19	
N		
nonsort mode	9	
nonsort precision stacking tray	6, 10,12	
P		
paper recommendations	8	
paper, size restrictions	8	
paper, weight restrictions	8	
power connections, recommended	5,20	
R		
reset key (illustration)	7	
S		
sort mode	9	
stack mode	9	
stack mode's interval	13	
staple cartridge	15,17	
staple cartridge, refilling	15	
stapler	6,14	
stapler,advise display	14	
stapler reset key	14	
status display	7,18	
T		
tray paper guides	6,10	
tray paper stopper	6,10	
troubleshooting tips	18	

RISO